

# COMPLEX ANALYSIS

---

*MUHAMMAD USMAN HAMID*

# COMPLEX ANALYSIS

**MUHAMMAD USMAN HAMID**

*University of Sargodha*

**SAIMA AKRAM**

*University of Gujraat*

The extension to the concept of complex numbers from that of real numbers was first necessitated by the solution of algebraic equations.

For example the quadratic equations

$$x^2 + 4 = 0, x^2 + x + 1 = 0, x^2 - 2x + 3 = 0$$

Do not possess real roots.

In order to find the solution of these equations, **Euler (1707-1783)** was first to introduce the symbol  $i = \sqrt{-1} \Rightarrow i^2 = -1$

**Gauss (1777-1855)** a German mathematician was first to prove in a satisfactory manner that some algebraic equations with real coefficients have complex roots in the form  $x \pm iy$  (Note that complex and irrational roots always occur in pairs)

## **REFERENCE BOOKS:**

- Complex variables and applications by J.W.Brown & R.V.Churchill.
- Schaums outlines of complex variables.
- Fundamentals of complex analysis by Dr.Muhammad Iqbal.
- Complex analysis with applications by D.G. Zill

*For video lectures*

*@ You tube visit*

***Learning with Usman Hamid***

*visit facebook page "mathwath"*

*or contact: 0323 – 6032785*

**Available on MathCity.org**

”پروفیسر بیٹی نتاشہ صاحبہ“

کے

نام

کہ

میری یہ کاوش

انہی کی بھرپور رہنمائی کا نتیجہ ہے۔

محمد عثمان حامد

# CHAPTER 1

## COMPLEX NUMBERS AND BASIC DEFINATIONS

**ORDERED PAIR:** A pair  $(x, y)$  such that  $(x, y) \neq (y, x)$  unless  $x = y$  is called an ordered pair. It can be represented as a point in complex plane.

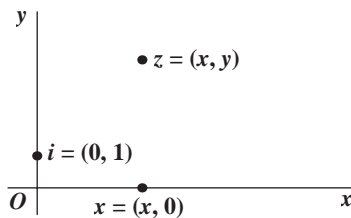

**COMPLEX NUMBERS:** It can be defined as ordered pairs  $(x, y)$  of real numbers that are to be interpreted as points in the complex plane, with rectangular coordinates  $x$  and  $y$ , just as real numbers  $x$  are thought of as points on the real line.

**Or** a **complex number** is any number of the form  $z = x + iy$  where 'x' and 'y' are real numbers and  $i$  is the imaginary unit.

- When real numbers  $x$  are displayed as points  $(x, 0)$  on the real axis, it is clear that the set of complex numbers includes the real numbers as a subset.
- Complex numbers of the form  $(0, y)$  correspond to points on the  $y$ -axis and are called **pure imaginary numbers** when  $y \neq 0$ . The  $y$ -axis is then referred to as the **imaginary axis**.
- The real numbers  $x$  and  $y$  are, moreover, known as the **real and imaginary parts** of  $z$ , respectively; and we write  $x = \text{Re } z$ ,  $y = \text{Im } z$ .
- Two complex numbers  $z_1$  and  $z_2$  are equal whenever they have the same real parts and the same imaginary parts. Thus **the statement  $z_1 = z_2$  means that  $z_1$  and  $z_2$  correspond to the same point in the complex, or  $z$ -plane. Also both will be equal if they have same modulus and Principal argument**

**COMPLEX PLANE:** The plane at which two lines are mutually perpendicular at a point O (origin) where x – axis is real line and y – axis is an imaginary line. Plane also named as Argand plane (diagram) or Gaussian Plane.

### SOME BASIC PROPERTIES

For two complex numbers  $z_1 = (x_1, y_1)$  and  $z_2 = (x_2, y_2)$

- $(x_1, y_1) + (x_2, y_2) = (x_1 + x_2, y_1 + y_2)$ ,
- $(x_1, y_1)(x_2, y_2) = (x_1x_2 - y_1y_2, x_1y_2 + x_2y_1)$ .
- $(x_1, 0) + (x_2, 0) = (x_1 + x_2, 0)$ ,
- $(x_1, 0)(x_2, 0) = (x_1x_2, 0)$ .
- **The complex number system is a natural extension of the real number system. Also complex cannot be comparable like real numbers.**
- Any complex number  $z = (x, y)$  can be written  $z = (x, 0) + (0, y)$ , and it is easy to see that  $(0, 1)(y, 0) = (0, y)$ .

Hence  $z = (x, 0) + (0, 1)(y, 0)$

- $z^2 = zz, z^3 = z^2z$ , etc. and  $z(z_1 + z_2) = zz_1 + zz_2$
- $(x_1 + iy_1) + (x_2 + iy_2) = (x_1 + x_2) + i(y_1 + y_2)$ ,
- $(x_1 + iy_1)(x_2 + iy_2) = (x_1x_2 - y_1y_2) + i(x_1y_2 + x_2y_1)$
- **$i^2 = -1$  for  $i = (0, 1)$**

**Proof:**  $\therefore (x_1, y_1)(x_2, y_2) = (x_1x_2 - y_1y_2, x_1y_2 + x_2y_1)$

$\therefore i^2 = i \cdot i = (0,1)(0,1) = (0 - 1, 0 + 0) = (-1, 0) \Rightarrow i^2 = -1$

- $Z_1 + Z_2 = Z_2 + Z_1, Z_1Z_2 = Z_2Z_1$  (commutative law)
- $(Z_1 + Z_2) + Z_3 = Z_1 + (Z_2 + Z_3), (Z_1Z_2)Z_3 = Z_1(Z_2Z_3)$  (associative laws)
- $Z_1 + Z_2 = (x_1 + x_2, y_1 + y_2) = (x_2 + x_1, y_2 + y_1) = Z_2 + Z_1$
- The additive identity  $0 = (0,0)$  and the multiplicative identity  $1 = (1,0)$
- There is associated with each complex number  $z = (x, y)$  an additive inverse  $-z = (-x, -y)$
- For any nonzero complex number  $z = (x, y)$  there is a number  $z^{-1}$  such that  $zz^{-1} = 1$ . This is multiplicative inverse. And  $z^{-1} = \left( \frac{x}{x^2+y^2}, \frac{-y}{x^2+y^2} \right)$
- $z_2 = z_2 \cdot 1 = z_2(z_1z_1^{-1}) = (z_1^{-1}z_1)z_2 = z_1^{-1}(z_1z_2) = z_1^{-1} \cdot 0 = 0$  if  $z_1z_2 = 0$
- Using the associative and commutative laws for multiplication  $(z_1z_2)(z_3z_4) = (z_1z_3)(z_2z_4)$
- $z(z_1 + z_2 + z_3) = zz_1 + zz_2 + zz_3$
- $\frac{z_1}{z_2} = \left( \frac{x_1x_2 + y_1y_2}{x_2^2 + y_2^2}, \frac{x_2y_1 - x_1y_2}{x_2^2 + y_2^2} \right)$
- A set of complex numbers form a field.
- Set of complex numbers satisfies scalar multiplication.

**Example:** Simplify  $\frac{4+i}{2-3i}$

**Solution:**  $\frac{4+i}{2-3i} = \frac{(4+i)(2+3i)}{(2-3i)(2+3i)} = \frac{5+14i}{13} = \frac{5}{13} + \frac{14}{13}i$

**Example:** Write down the binomial expansion form of  $(z_1 + z_2)^n$

**Solution:**  $(z_1 + z_2)^n = \left[ z_2 \left( 1 + \frac{z_1}{z_2} \right) \right]^n = z_2^n (1 + z_1 z_2^{-1})^n$

$$(z_1 + z_2)^n = z_2^n \left[ 1 + n(z_1 z_2^{-1}) + \frac{n(n-1)}{2!} (z_1 z_2^{-1})^2 + \dots \right]$$

$$(z_1 + z_2)^n = z_2^n \left[ 1 + n(z_1 z_2^{-1}) + \frac{n(n-1)}{2!} z_1^2 z_2^{-2} + \dots \right]$$

$$(z_1 + z_2)^n = z_2^n + n(z_1 z_2^{n-1}) + \frac{n(n-1)}{2!} z_1^2 z_2^{n-2} + \dots$$

$$(z_1 + z_2)^n = \sum_{k=0}^n n_{C_k} z_1^k z_2^{n-k} = \sum_{k=0}^n \binom{n}{k} z_1^k z_2^{n-k}$$

**Example:** Show that  $(z_1 + z_2)^{m+1} = \sum_{k=0}^{m+1} \binom{m+1}{k} z_1^k z_2^{m+1-k}$

**Solution:**

$$(z_1 + z_2)^{m+1} = (z_1 + z_2)(z_1 + z_2)^m = (z_1 + z_2) \sum_{k=0}^m \binom{m}{k} z_1^k z_2^{m-k}$$

$$(z_1 + z_2)^{m+1} = \sum_{k=0}^m \binom{m}{k} z_1^k z_2^{m+1-k} + \sum_{k=0}^m \binom{m}{k} z_1^{k+1} z_2^{m-k}$$

$$(z_1 + z_2)^{m+1} = \sum_{k=0}^m \binom{m}{k} z_1^k z_2^{m+1-k} + \sum_{k=1}^m \binom{m}{k-1} z_1^k z_2^{m+1-k}$$

$$(z_1 + z_2)^{m+1} = z_2^{m+1} + \sum_{k=1}^m \binom{m}{k} z_1^k z_2^{m+1-k} + z_1^{m+1} + \sum_{k=1}^m \binom{m}{k-1} z_1^k z_2^{m+1-k}$$

$$(z_1 + z_2)^{m+1} = z_1^{m+1} + \sum_{k=1}^m \left[ \binom{m}{k-1} + \binom{m}{k} \right] z_1^k z_2^{m+1-k} + z_2^{m+1}$$

$$(z_1 + z_2)^{m+1} = \binom{m+1}{k} z_1^k z_2^{m+1-k}$$

Replace  
'k' with  
'k-1'

**Exercises 1: (visit @ Youtube “learning with Usman Hamid”)**

- 1) Verify that
  - a)  $(\sqrt{2} - i) - i(1 - \sqrt{2}i) = -2i$
  - b)  $(2, -3)(-2, 1) = (-1, 8)$
  
- 2) Show that
  - a)  $\operatorname{Re}(iz) = -\operatorname{Im} z$
  - b)  $\operatorname{Im}(iz) = \operatorname{Re} z$ .
  
- 3) Show that  $(1 + z)^2 = 1 + 2z + z^2$ .
  
- 4) Verify that each of the two numbers  $z = 1 \pm i$  satisfies the equation  $z^2 - 2z + 2 = 0$ .
  
- 5) Briefly answer the followings;
  - a) Write  $(x, y) + (u, v) = (x, y)$  and point out how it follows that the complex number  $0 = (0, 0)$  is unique as an additive identity
  - b) Likewise, write  $(x, y)(u, v) = (x, y)$  and show that the number  $1 = (1, 0)$  is a unique multiplicative identity.
  - c) Use  $-1 = (-1, 0)$  and  $z = (x, y)$  to show that  $(-1)z = -z$ .
  - d) Use  $i = (0, 1)$  and  $y = (y, 0)$  to verify that  $-(iy) = (-i)y$
  - e) Solve the equation  $z^2 + z + 1 = 0$  for  $z = (x, y)$  by writing  $(x, y)(x, y) + (x, y) + (1, 0) = (0, 0)$  and then solving a pair of simultaneous equations in  $x$  and  $y$ .
  
- 6) Reduce each of these quantities into real numbers number:
  - (a)  $\frac{1+2i}{3-4i} + \frac{2-i}{5i}$
  - (b)  $\frac{5i}{(1-i)(2-i)(3-i)}$
  - (c)  $(1 - i)^4$
  
- 7) Show that  $\frac{1}{1/z} = z$
  
- 8) Prove that if  $z_1 z_2 z_3 = 0$ , then at least one of the three factors is zero.
  
- 9) Derive the identity  $\begin{pmatrix} z_1 \\ z_3 \end{pmatrix} \begin{pmatrix} z_2 \\ z_4 \end{pmatrix} = \begin{pmatrix} z_1 z_2 \\ z_3 z_4 \end{pmatrix}$
  
- 10) Derive the cancellation law  $\frac{z_1 z}{z_2 z} = \frac{z_1}{z_2}$
  
- 11) Use the definition of complex numbers as an ordered pair of real numbers and prove that  $(a, b) = a(1, 0) + b(0, 1)$  where  $(0, 1)(0, 1) = (-1, 0)$

## VECTORS INTERPRETATION OF COMPLEX NUMBER (GRAPHICAL REPRESENTATION)

A complex number  $z = x + iy$  can be considered as a vector  $\overrightarrow{OP}$  in complex plane whose initial point is the origin and terminal point is the point  $P(x, y)$

We sometime call  $\overrightarrow{OP} = x + iy$  the position vector of 'P'

For example:  $z = x + iy$  and  $z = -2 + i$  graphically represented as below;

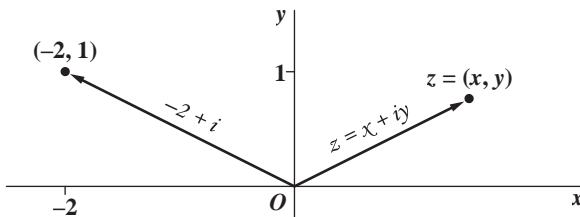

When  $z_1 = x_1 + iy_1$  and  $z_2 = x_2 + iy_2$ , the sum  $z_1 + z_2 = (x_1 + x_2) + i(y_1 + y_2)$  Corresponds to the point  $(x_1 + x_2, y_1 + y_2)$ . It also corresponds to a vector with those coordinates as its components. Hence  $z_1 + z_2$  may be obtained vectorially as shown in Fig.

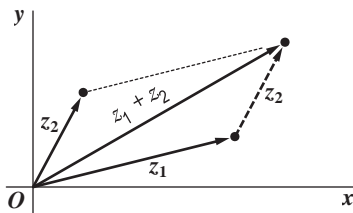

**Keep in mind:** Two vectors having the same length or magnitude and direction but different initial points are considered to be equal.

### Exercises 2: (visit @ Youtube “learning with Usman Hamid”)

Locate the numbers  $z_1 + z_2$  and  $z_1 - z_2$  vectorially when

- i.  $z_1 = 2i$  ;  $z_2 = \frac{2}{3} - i$
- ii.  $z_1 = (-\sqrt{3}, 1)$  ;  $z_2 = (\sqrt{3}, 0)$
- iii.  $z_1 = (-3, 1)$  ;  $z_2 = (1, 4)$
- iv.  $z_1 = x_1 + iy_1$  ;  $z_2 = x_1 - iy_1$
- v. perform both indicated operations analytically as well as graphically for  $(3 + 4i) + (5 + 2i)$



## THE MODULUS OR ABSOLUTE VALUE OF COMPLEX NUMBER

The modulus or absolute value of a complex number  $z = x + iy$  is

defined as  $|z| = \sqrt{x^2 + y^2}$  which is non – negative real quantity.

- **Geometrically**, the number  $|z|$  is the distance between the point  $(x, y)$  and the origin, or the length of the radius vector representing  $z$ . It reduces to the usual absolute value in the real number system when  $y=0$ .
- The inequality  $z_1 < z_2$  is meaningless unless both  $z_1$  and  $z_2$  are real, the statement  $|z_1| < |z_2|$  means that the point  $z_1$  is closer to the origin than the point  $z_2$  is.

**Example:** Since  $|-3 + 2i| = \sqrt{13}$  and  $|1 + 4i| = \sqrt{17}$ , we know that the point  $-3 + 2i$  is closer to the origin than  $1 + 4i$  is.

**Remark:** The complex numbers  $z$  corresponding to the points lying on the circle with center  $z_0$  and radius  $R$  thus satisfy the equation  $|z - z_0| = R$ , and conversely. We refer to this set of points simply as the circle

$$|z - z_0| = R.$$

**Example:** The equation  $|z - 1 + 3i| = 2$  represents the circle whose center is  $z_0 = (1, -3)$  and whose radius is  $R = 2$ .

**Example:** The equation  $|z - 4| + |z + 4i| = 10$  after rearranging  $|z - 4i| + |z - (-4i)| = 10$  represents the ellipse with foci  $F(0, 4)$  and  $F'(0, -4)$

**Example:** The equation  $|z - 1| = |z + i|$  represents the line through the origin whose slope is  $-1$

**Example:** The equation  $|z| + |z - 2| = 4$  represents the ellipse where  $|z|$  is the distance from origin.

### Exercises 3: (visit @ Youtube “learning with Usman Hamid”)

In each case, sketch the set of points determined by the given condition:

(a)  $|z - 1 + i| = 1$

(b)  $|z + i| \leq 3$

(c)  $|2z - i| = 4$

(d)  $|z - 4i| \geq 4$

(e)  $\left| \frac{z-3}{z+3} \right| = 2$

(f)  $\left| \frac{z-3}{z+3} \right| < 2$

**BASIC PROPERTIES:** It also follows from definition that the real numbers  $|z|$ ,  $\text{Re } z = x$ , and  $\text{Im } z = y$  are related as follows;

- $|z|^2 = (\text{Re}(z))^2 + (\text{Im}(z))^2$
- $\text{Re } z \leq |\text{Re } z| \leq |z|$  and  $\text{Im } z \leq |\text{Im } z| \leq |z|$ .
- $|z|^2 = z\bar{z}$
- $|z| = |\bar{z}|$
- $|z|^2 \geq (\text{Re}(z))^2$
- $|z|^2 \geq (\text{Im}(z))^2$
- $|z_1 z_2| = |z_1| |z_2|$

**Proof:**  $|z_1 z_2|^2 = (z_1 z_2)(\overline{z_1 z_2}) = z_1 \bar{z}_1 z_2 \bar{z}_2 = |z_1|^2 |z_2|^2 \Rightarrow |z_1 z_2| = |z_1| |z_2|$

- $\left| \frac{z_1}{z_2} \right| = \frac{|z_1|}{|z_2|}$  ;  $z_2 \neq 0$

**Proof:**  $\left| \frac{z_1}{z_2} \right|^2 = \left( \frac{z_1}{z_2} \right) \overline{\left( \frac{z_1}{z_2} \right)} = \frac{z_1 \bar{z}_1}{z_2 \bar{z}_2} = \frac{|z_1|^2}{|z_2|^2} \Rightarrow \left| \frac{z_1}{z_2} \right| = \frac{|z_1|}{|z_2|}$

- $|z_1 + z_2| \leq |z_1| + |z_2|$  (*triangular inequality*)

**Proof:**  $|z_1 + z_2|^2 = (z_1 + z_2)(\overline{z_1 + z_2}) = (z_1 + z_2)(\bar{z}_1 + \bar{z}_2)$

$$|z_1 + z_2|^2 = z_1 \bar{z}_1 + z_1 \bar{z}_2 + z_2 \bar{z}_1 + z_2 \bar{z}_2 = |z_1|^2 + z_1 \bar{z}_2 + \overline{z_1 \bar{z}_2} + |z_2|^2$$

$$|z_1 + z_2|^2 = |z_1|^2 + 2\text{Re}(z_1 \bar{z}_2) + |z_2|^2 \quad \therefore z + \bar{z} = 2\text{Re}(z)$$

$$|z_1 + z_2|^2 \leq |z_1|^2 + 2|z_1 \bar{z}_2| + |z_2|^2 \quad \therefore |z| \geq \text{Re}(z)$$

$$|z_1 + z_2|^2 \leq |z_1|^2 + 2|z_1| |\bar{z}_2| + |z_2|^2 \quad \therefore |z_1 z_2| = |z_1| |z_2|$$

$$|z_1 + z_2|^2 \leq |z_1|^2 + 2|z_1| |z_2| + |z_2|^2 \quad \therefore |\bar{z}_2| = |z_2|$$

$$|z_1 + z_2|^2 \leq [|z_1| + |z_2|]^2$$

$$|z_1 + z_2| \leq |z_1| + |z_2|$$

$$|z_1 + z_2 + \dots + z_n| \leq |z_1| + |z_2| + \dots + |z_n| \quad \text{in general}$$

$$\Rightarrow \left| \sum_{i=1}^n z_i \right| \leq \sum_{i=1}^n |z_i|$$

- $||z_1| - |z_2|| \leq |z_1 - z_2|$

**Proof:** consider  $z_1 = (z_1 - z_2) + z_2 \Rightarrow |z_1| = |(z_1 - z_2) + z_2|$

$$\Rightarrow |z_1| \leq |z_1 - z_2| + |z_2| \Rightarrow |z_1| - |z_2| \leq |z_1 - z_2| \dots \dots \dots (A)$$

Similarly  $z_2 = (z_2 - z_1) + z_1 \Rightarrow |z_2| = |(z_2 - z_1) + z_1|$

$$\Rightarrow |z_2| \leq |z_2 - z_1| + |z_1| \Rightarrow |z_2| - |z_1| \leq |-(z_1 - z_2)|$$

$$\Rightarrow -[|z_1| - |z_2|] \leq |z_1 - z_2| \Rightarrow |z_1| - |z_2| \geq -|z_1 - z_2| \dots \dots \dots (B)$$

From (A) and (B)  $||z_1| - |z_2|| \leq |z_1 - z_2|$

**Example:** If a point  $z$  lies on the unit circle  $|z| = 1$  about the origin,

$$\text{then } |z - 2| = |z + (-2)| \leq |z| + |-2| = 1 + 2 = 3 \Rightarrow |z - 2| \leq 3$$

$$\text{And } |z - 2| = |z + (-2)| \geq ||z| - |-2|| = |1 - 2| = 1 \Rightarrow |z - 2| \geq 1$$

**Example:** If a point  $z$  lies on the circle  $|z| = 2$ , then

$$|3 + z + z^2| \leq |3| + |z| + |z^2| = |3| + |2| + |2^2| = 9$$

$$\Rightarrow |3 + z + z^2| \leq 9$$

**Example:** If  $n$  is a positive integer and  $P(z)$  is a polynomial of degree  $n$  then for some positive number  $R$ , the reciprocal  $1/P(z)$  satisfies the inequality  $\left| \frac{1}{P(z)} \right| < \frac{2}{|a_n|R^n}$  whenever  $|z| > R$

**Solution:** Consider  $P(z) = a_0 + a_1z + \dots + a_nz^n$  is a polynomial of degree  $n$ .

Take  $w = \frac{a_0}{z^n} + \frac{a_1}{z^{n-1}} + \dots + \frac{a_{n-1}}{z} \dots \dots \dots (i)$

Then  $P(z) = (a_n + w)z^n \dots \dots \dots (ii)$

$(i) \Rightarrow wz^n = a_0 + a_1z + a_2z^2 + \dots + a_{n-1}z^{n-1}$

$\Rightarrow |wz^n| = |a_0 + a_1z + a_2z^2 + \dots + a_{n-1}z^{n-1}|$

$\Rightarrow |w||z|^n \leq |a_0| + |a_1||z| + |a_2||z|^2 + \dots + |a_{n-1}||z|^{n-1}$

$\Rightarrow |w| \leq \frac{|a_0|}{|z|^n} + \frac{|a_1|}{|z|^{n-1}} + \dots + \frac{|a_{n-1}|}{|z|}$

Note that a sufficiently large positive number  $R$  can be found such that each of the quotients on the right in above inequality is less than the number  $\frac{|a_n|}{(2n)}$  when  $|z| > R$  and so

$|w| < n \frac{|a_n|}{(2n)} = \frac{|a_n|}{2}$  when  $|z| > R$

Consequently  $|a_n + w| \geq |a_n| - |w| > \frac{|a_n|}{2}$  when  $|z| > R$

$(ii) \Rightarrow |P_n(z)| = |a_n + w||z|^n > \frac{|a_n|}{2}|z|^n > \frac{|a_n|}{2}R^n$  When  $|z| > R$

$\Rightarrow \left| \frac{1}{P(z)} \right| < \frac{2}{|a_n|R^n}$  Whenever  $|z| > R$

#### Exercises 4: (visit @ Youtube "learning with Usman Hamid")

1. Show that  $\operatorname{Re} z \leq |\operatorname{Re} z| \leq |z|$
2. Verify  $|z_1| - |z_2| \leq |z_1 + z_2|$  involving  $\operatorname{Re} z$ ,  $\operatorname{Im} z$ , and  $|z|$
3. When  $|z_3| \neq |z_4|$  show that  $\frac{\operatorname{Re}(z_1+z_2)}{|z_3+z_4|} \leq \frac{|z_1|+|z_2|}{|z_3|+|z_4|}$
4. If  $z = \frac{4i}{3+4i}$  then find  $|z|$
5. Verify that  $\sqrt{2}|z| \geq |\operatorname{Re}(z)| + |\operatorname{Im}(z)|$
6. Using mathematical induction show that  $|z^n| = |z|^n$
7. Show that  $\left| \frac{1}{z^4 - 4z^2 + 3} \right| \leq \frac{1}{3}$  when  $z$  lies in the circle  $|z| = 2$

## COMPLEX CONJUGATES

The *complex conjugate*, or simply the conjugate, of a complex number  $z = x + iy$  is defined as the complex number  $x - iy$  and is denoted by  $\bar{z}$ ; that is,  $\bar{z} = x - iy$ .

The number  $\bar{z}$  is represented by the point  $(x, -y)$ , which is the reflection (mirror image) in the real axis of the point  $(x, y)$  representing  $z$

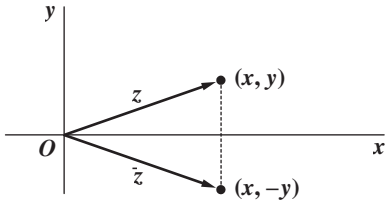

If  $z_1 = x_1 + iy_1$  and  $z_2 = x_2 + iy_2$ , then

- $\overline{\bar{z}} = z$
- $\overline{z_1 + z_2} = \bar{z}_1 + \bar{z}_2$
- $\overline{z_1 - z_2} = \bar{z}_1 - \bar{z}_2$
- $\overline{z_1 z_2} = \bar{z}_1 \bar{z}_2$
- $\overline{\left(\frac{z_1}{z_2}\right)} = \frac{\bar{z}_1}{\bar{z}_2}$
- $|\bar{z}| = |z|$
- $z\bar{z} = |z|^2$
- $z + \bar{z} = 2x = 2\text{Re}(z) \Rightarrow \text{Re}(z) = \frac{z + \bar{z}}{2}$
- $z - \bar{z} = 2iy = 2\text{Im}(z) \Rightarrow \text{Im}(z) = \frac{z - \bar{z}}{2i}$
- **If  $z = \bar{z}$  then complex status of  $z$  is that  $z$  will be a real number.  
i.e.  $z = \bar{z}$  iff  $z$  is a real. We may say that  $z$  is self-conjugate.**
- $z^2 = \bar{z}^2$  iff  $z$  is either real or pure imaginary.

**Example:**

$$\frac{-1+3i}{2-i} = \frac{(-1+3i)(2+i)}{(2-i)(2+i)} = \frac{-5+5i}{|2-i|^2} = -1 + i$$

**Example:** If  $z$  is a point inside the circle centered at the origin with radius 2, so that  $z < 2$ , it follows from the generalized triangle inequality

$$\begin{aligned} |z^3 + 3z^2 - 2z + 1| &\leq |z^3| + 3|z^2| + 2|z| + 1 \\ |z^3 + 3z^2 - 2z + 1| &\leq |z|^3 + 3|z|^2 + 2|z| + 1 < 25 \quad \therefore |z^n| = |z|^n \\ |z^3 + 3z^2 - 2z + 1| &< 25 \end{aligned}$$

**Exercises 5: (visit @ Youtube “learning with Usman Hamid”)**

1. Show that
  - i.  $\overline{\bar{z} + 3i} = z - 3i$
  - ii.  $\overline{i\bar{z}} = -iz$
  - iii.  $\overline{(2 + i)^2} = 3 - 4i$
  - iv.  $|(2\bar{z} + 5)(\sqrt{2} - i)| = \sqrt{3}|2z + 5|$
2. Sketch the set of points determined by the condition;
  - i.  $Re(\bar{z} - i) = 2$
  - ii.  $|2z - i| = 4$
3. Show that
  - i.  $\overline{\bar{z}_1 \bar{z}_2 \bar{z}_3} = \bar{z}_1 \bar{z}_2 \bar{z}_3$
  - ii.  $\overline{z^4} = \bar{z}^4$
4. Verify for non-zero  $z_2, z_3$ 
  - i.  $\overline{\left(\frac{z_1}{z_2 z_3}\right)} = \frac{\bar{z}_1}{\bar{z}_2 \bar{z}_3}$
  - ii.  $\left|\frac{z_1}{z_2 z_3}\right| = \frac{|z_1|}{|z_2| |z_3|}$
5. Show that  $|Re(2 + \bar{z} + z^3)| \leq 4$  when  $|z| \leq 1$
6. By using mathematical induction show that
  - i.  $\overline{\bar{z}_1 \bar{z}_2 \bar{z}_3 \dots \bar{z}_n} = \bar{z}_1 \bar{z}_2 \bar{z}_3 \dots \bar{z}_n$
  - ii.  $\overline{z_1 + z_2 + z_3 \dots + z_n} = \bar{z}_1 + \bar{z}_2 + \bar{z}_3 \dots + \bar{z}_n$
7. For any real numbers  $\sum_{i=0}^n a_i$  ;  $n \geq 1$  and for a complex number ‘z’ show that
 
$$\overline{a_0 + a_1 z + a_2 z^2 + \dots + a_n z^n} = a_0 + a_1 \bar{z} + a_2 \bar{z}^2 + \dots + a_n \bar{z}^n$$
8. Show that the equation  $|z - z_0| = R$  of a circle centered at  $z_0$  with radius R can be written as  $|z|^2 - 2Re(z\bar{z}_0) + |z_0|^2 = R^2$
9. Show that the hyperbola  $x^2 - y^2 = 1$  can be written as  $z^2 + \bar{z}^2 = 2$
10. Express  $2x + y = 5$  in terms of complex conjugates.
11. Express  $x^2 + y^2 = 36$  in terms of complex conjugates.
12. If the sum and product of two complex numbers are both real, then prove that the two numbers must either be real or conjugate.

## ARGUMENT (AMPLITUDE) OF COMPLEX NUMBERS

Let  $r$  and  $\theta$  be polar coordinates of the point  $(x, y)$  that corresponds to a *nonzero* complex number  $z = x + iy$ . Since  $x = r \cos\theta$  and  $y = r \sin\theta$ , the number  $z$  can be written in **polar form** as

$$z = r(\cos\theta + i \sin\theta)$$

- If  $z = 0$ , the coordinate  $\theta$  is undefined; and so it is understood that  $z \neq 0$  whenever polar coordinates are used.
- In complex analysis, the real number  $r$  is not allowed to be negative and is the length of the **radius vector** for  $z$ ; that is,  $r = |z| = \sqrt{x^2 + y^2}$ .
- The real number  $\theta$  represents the angle, measured in radians, that  $z$  makes with the positive real axis when  $z$  is interpreted as a radius vector (Fig). and  $\theta = \text{Tan}^{-1}\left(\frac{y}{x}\right)$  is called an **argument** of  $z$ , and the set of all such values is denoted by **arg**  $z$ .
- The **principal value** of  $\text{arg } z$ , denoted by **Arg**  $z$ , is that unique value  $\theta$  such that  $-\pi < \theta \leq \pi$ . Evidently, then,  $\text{arg } z = \text{Arg } z + 2n\pi$  ( $n = 0, \pm 1, \pm 2, \dots$ ).

Also, when  $z$  is a negative real number,  $\text{Arg } z$  has value  $\pi$ , not  $-\pi$ .

At origin  $\text{Arg } z$  not defined.

Some authors use  $-\pi \leq \theta < \pi$  but we follow previous one.

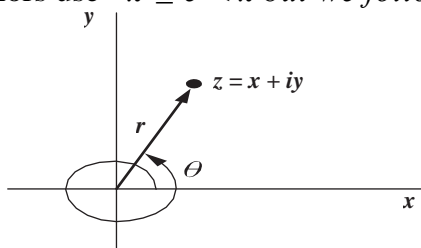

## HOW TO FIND ARGUMENT?

- $\theta = \text{Tan}^{-1}\left(\frac{y}{x}\right)$  ;  $x > 0$
- $\theta = \pi + \text{Tan}^{-1}\left(\frac{y}{x}\right)$  ;  $x < 0, y \geq 0$
- $\theta = -\pi + \text{Tan}^{-1}\left(\frac{y}{x}\right)$  ;  $x < 0, y < 0$
- $\theta = \frac{\pi}{2}$ ;  $x = 0, y \geq 0$
- $\theta = -\frac{\pi}{2}$ ;  $x = 0, y < 0$
- $\text{arg } z = \text{Arg } z + 2n\pi$  ( $n = 0, \pm 1, \pm 2, \dots$ ).
- $\text{Arg } z = \text{arg } z - 2n\pi$  ( $n = 0, \pm 1, \pm 2, \dots$ ).

**Example:** Find the argument of the complex number  $z = -1 - i$

**Solution:** The complex number  $z = -1 - i$ , which lies in the third quadrant, has **principal argument**  $-3\pi/4$ . That is,

$$\text{Arg}(-1 - i) = -\frac{3\pi}{4}$$

It must be emphasized that because of the restriction  $-\pi < \theta \leq \pi$  of the principal argument  $\theta$ , it is *not true* that  $\text{Arg}(-1 - i) = \frac{5\pi}{4}$

Now  $\text{arg } z = \text{Arg } z + 2n\pi = -\frac{3\pi}{4} + 2n\pi$  ( $n = 0, \pm 1, \pm 2, \dots$ ).

## EXPONENTIAL FORM

The symbol  $e^{i\theta}$ , or  $\exp(i\theta)$ , is defined by means of **Euler's formula** as  $e^{i\theta} = \cos \theta + i \sin \theta$ , where  $\theta$  is to be measured in radians. It enables one to write the polar form more compactly in *exponential form* as

$$z = re^{i\theta}$$

**Example:** Write exponential form of the complex number  $z = -1 - i$

**Solution:** Since for the complex number  $z = -1 - i$ , which lies in the third quadrant,  $\theta = -\frac{3\pi}{4}$  And  $r = \sqrt{2}$

Then  $z = re^{i\theta} \Rightarrow -1 - i = \sqrt{2}e^{i(-\frac{3\pi}{4})} \Rightarrow -1 - i = \sqrt{2}e^{i(-\frac{3\pi}{4} + 2n\pi)}$   
( $n = 0, \pm 1, \pm 2, \dots$ ).

**Note:** Expression  $z = re^{i\theta}$  with  $r = 1$  tells us that the numbers  $e^{i\theta}$  lie on the circle centered at the origin with radius unity, as shown in Fig. Values of  $e^{i\theta}$  are, then, immediate from that figure, without reference to Euler's formula. It is, for instance, geometrically obvious that

$$e^{i\pi} = -1, e^{-\frac{i\pi}{2}} = -i, \text{ and } e^{i4\pi} = 1$$

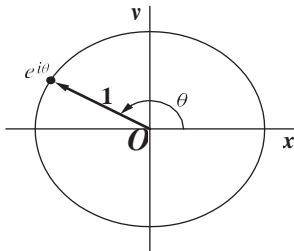

**Note:** The equation  $z = Re^{i\theta}$  ( $0 \leq \theta \leq 2\pi$ ) is a parametric representation of the circle  $|z| = R$ , centered at the origin with radius  $R$ . As the parameter  $\theta$  increases from 0 to  $2\pi$ , the point  $z$  starts from the positive real axis and traverses the circle once in the counterclockwise direction. More generally, the circle  $|z - z_0| = R$ , whose center is  $z_0$  and whose radius is  $R$ , has the parametric representation  $z = z_0 + Re^{i\theta}$  ( $0 \leq \theta \leq 2\pi$ ).

This can be seen vectorially (Fig) by noting that a point  $z$  traversing the circle  $|z - z_0| = R$  once in the counterclockwise direction corresponds to the sum of the fixed vector  $z_0$  and a vector of length  $R$  whose angle of inclination  $\theta$  varies from 0 to  $2\pi$ .

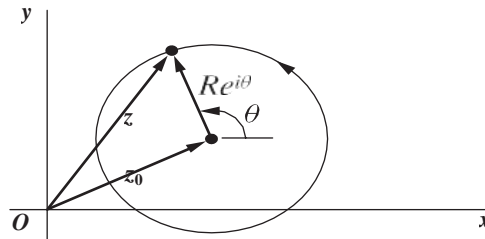

## PRODUCTS AND POWERS IN EXPONENTIAL FORM

Simple trigonometry tells us that  $e^{i\theta}$  has the familiar additive property of the exponential function in calculus:

$$\begin{aligned} e^{i\theta_1} e^{i\theta_2} &= (\cos \theta_1 + i \sin \theta_1)(\cos \theta_2 + i \sin \theta_2) \\ &= (\cos \theta_1 \cos \theta_2 - \sin \theta_1 \sin \theta_2) + i(\sin \theta_1 \cos \theta_2 + \cos \theta_1 \sin \theta_2) \\ &= \cos(\theta_1 + \theta_2) + i \sin(\theta_1 + \theta_2) = e^{i(\theta_1 + \theta_2)}. \end{aligned}$$

Thus, if  $z_1 = r_1 e^{i\theta_1}$  and  $z_2 = r_2 e^{i\theta_2}$ , the product  $z_1 z_2$  has exponential form

- $z_1 z_2 = r_1 e^{i\theta_1} r_2 e^{i\theta_2} = r_1 r_2 e^{i\theta_1} e^{i\theta_2} = (r_1 r_2) e^{i(\theta_1 + \theta_2)}$ .
- $\frac{z_1}{z_2} = \frac{r_1 e^{i\theta_1}}{r_2 e^{i\theta_2}} = \frac{r_1}{r_2} \cdot \frac{e^{i\theta_1} e^{-i\theta_2}}{e^{i\theta_2} e^{-i\theta_2}} = \frac{r_1}{r_2} \cdot \frac{e^{i(\theta_1 - \theta_2)}}{e^{i0}} = \frac{r_1}{r_2} e^{i(\theta_1 - \theta_2)}$
- $z^{-1} = \frac{1}{z} = \frac{1 e^{i0}}{r e^{i\theta}} = \frac{1}{r} e^{i(0 - \theta)} = \frac{1}{r} e^{-i\theta}$
- $z^n = r^n e^{in\theta}$  ( $n = 0, \pm 1, \pm 2, \dots$ ).
- for  $n = m + 1$ :  
 $z^{m+1} = z^m z = r^m e^{im\theta} r e^{i\theta} = (r^m r) e^{i(m\theta + \theta)} = r^{m+1} e^{i(m+1)\theta}$ .
- $z^n = (z^{-1})^m$  where  $m = -n = 1, 2, \dots$ .
- $(z^{-1})^n = \left[ \frac{1}{r} e^{-i\theta} \right]^n = \left[ \frac{1}{r} \right]^n e^{-in\theta}$



**Example:** Write  $(-1 + i)^7$  in rectangular form.

**Solution:**

$$(-1 + i)^7 = \left(\sqrt{2}e^{i\left(\frac{3\pi}{4}\right)}\right)^7 = (2^3e^{i5\pi})\left(2^{1/2}e^{i\left(\frac{\pi}{4}\right)}\right) = -8\left(2^{1/2}e^{i\left(\frac{\pi}{4}\right)}\right)$$

$$(-1 + i)^7 = -8\left[\sqrt{2}\left(\frac{1}{\sqrt{2}} + \frac{i}{\sqrt{2}}\right)\right] = -8(1 + i)$$

**Exercises 6: (visit @ Youtube “learning with Usman Hamid”)**

1. Write  $(\sqrt{3} + i)^7$  in rectangular form.
2. By writing the individual factors on the left in exponential form, performing the needed operations, and finally changing back to rectangular coordinates, show that
  - i.  $i(1 - \sqrt{3}i)(\sqrt{3} + i) = 2(1 + \sqrt{3}i)$
  - ii.  $\frac{5i}{2+i} = 1 + 2i$
  - iii.  $(\sqrt{3} + i)^6 = -64$
  - iv.  $(1 - \sqrt{3}i)^{-10} = 2^{-11}(-1 + \sqrt{3}i)$

**DE MOIVRE’S FORMULA:**

For  $z^n = r^n e^{in\theta}$  ( $n = 0, \pm 1, \pm 2, \dots$ ) we have  $(e^{i\theta})^n = e^{in\theta}$  ( $n = 0, \pm 1, \pm 2, \dots$ ).

When written in the form

$$(\cos \theta + i \sin \theta)^n = \cos n\theta + i \sin n\theta \quad (n = 0, \pm 1, \pm 2, \dots),$$

This is known as *de Moivre’s formula*.

**Remarks:**

- $(\cos \theta + i \sin \theta)^2 = \cos 2\theta + i \sin 2\theta$ ,
- Or  $\cos^2 \theta - \sin^2 \theta + i2 \sin \theta \cos \theta = \cos 2\theta + i \sin 2\theta$ .
- By equating real parts and then imaginary parts here, we have the familiar trigono metric identities  
 $\cos 2\theta = \cos^2 \theta - \sin^2 \theta$ ,  $\sin 2\theta = 2 \sin \theta \cos \theta$ .

**Question:** Prove de Moivre’s formula

$$(\cos \theta + i \sin \theta)^n = \cos n\theta + i \sin n\theta \quad (n = 0, \pm 1, \pm 2, \dots)$$

**Proof :** By using mathematical induction we assume that result is true for the particular positive integer ‘k’ i.e.

$$(\cos \theta + i \sin \theta)^k = \cos k\theta + i \sin k\theta \quad (k = 0, \pm 1, \pm 2, \dots)$$

Then multiplying  $(\cos \theta + i \sin \theta)$  we get

$$(\cos \theta + i \sin \theta)^{k+1} = (\cos k\theta + i \sin k\theta)(\cos \theta + i \sin \theta)$$

$$(\cos \theta + i \sin \theta)^{k+1} = \cos (k+1)\theta + i \sin (k+1)\theta$$

Result is true for  $n = k+1$  and hence proved.

**Exercise 7: (visit @ Youtube “learning with Usman Hamid”)**

Use de Moivre’s formula to derive the following trigonometric identities:

$$(a) \cos 3\theta = \cos^3 \theta - 3 \cos \theta \sin^2 \theta; \quad (b) \sin 3\theta = 3 \cos^2 \theta \sin \theta - \sin^3 \theta.$$

## ARGUMENTS OF PRODUCTS AND QUOTIENTS

If  $z_1 = r_1 e^{i\theta_1}$  and  $z_2 = r_2 e^{i\theta_2}$ , then expression  $z_1 z_2 = (r_1 r_2) e^{i(\theta_1 + \theta_2)}$  can be used to obtain an important identity involving arguments:

$$\mathbf{arg}(z_1 z_2) = \mathbf{arg} z_1 + \mathbf{arg} z_2.$$

Suppose  $z_1, z_2$  be two non-zero complex numbers and let  $r_1, r_2$  be the moduli and  $\theta_1, \theta_2$  be the arguments. Then  $z_1 z_2 = (r_1 r_2) e^{i(\theta_1 + \theta_2)}$

$$\text{Then } \mathbf{arg}(z_1 z_2) = \theta_1 + \theta_2 = \mathbf{arg} z_1 + \mathbf{arg} z_2$$

In general

$$\mathbf{arg}(z_1 z_2 \dots z_n) = \theta_1 + \theta_2 + \dots + \theta_n = \mathbf{arg} z_1 + \mathbf{arg} z_2 + \dots + \mathbf{arg} z_n$$

But for principal argument

$$\mathbf{Arg}(z_1 z_2 \dots z_n) \neq \mathbf{Arg} z_1 + \mathbf{Arg} z_2 + \dots + \mathbf{Arg} z_n$$

$$\text{Also } \frac{z_1}{z_2} = \frac{r_1}{r_2} e^{i(\theta_1 - \theta_2)} \Rightarrow \mathbf{arg} \left( \frac{z_1}{z_2} \right) = \theta_1 - \theta_2 = \mathbf{arg} z_1 - \mathbf{arg} z_2$$

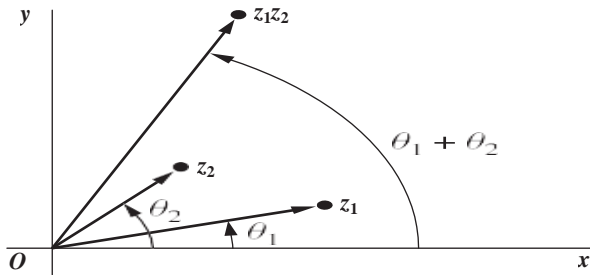

**Example:** Show that  $\mathbf{arg}(z_1 z_2) = \mathbf{arg} z_1 + \mathbf{arg} z_2$   
also  $\mathbf{Arg}(z_1 z_2) \neq \mathbf{Arg} z_1 + \mathbf{Arg} z_2$  when  $z_1 = -1$  and  $z_2 = i$

**Solution:** when  $z_1 = -1$  and  $z_2 = i$  then  $\mathbf{Arg}(z_1 z_2) = \mathbf{Arg}(-i) = -\frac{\pi}{2}$  but

$$\mathbf{Arg} z_1 + \mathbf{Arg} z_2 = \pi + \frac{\pi}{2} = \frac{3\pi}{2} \text{ for both we use } n = 0$$

Then  $\mathbf{Arg}(z_1 z_2) \neq \mathbf{Arg} z_1 + \mathbf{Arg} z_2$

$$\text{But for } n = 1 \text{ we get } \mathbf{arg}(z_1 z_2) = \mathbf{Arg}(z_1 z_2) + 2\pi = -\frac{\pi}{2} + 2\pi = \frac{3\pi}{2}$$

Then  $\mathbf{arg}(z_1 z_2) = \mathbf{arg} z_1 + \mathbf{arg} z_2$

**Example:** Find the principal argument  $\mathbf{Arg} z$  when  $z = \frac{i}{-1-i}$

**Solution:** use  $\mathbf{arg}(z) = \mathbf{arg}(i) - \mathbf{arg}(-1-i)$

$$\text{And Since } \mathbf{Arg}(i) = \frac{\pi}{2} \text{ and } \mathbf{Arg}(-1-i) = -\frac{3\pi}{4}$$

one value of  $\mathbf{arg} z$  is  $5\pi/4$  not a principal value

$$\text{then } \mathbf{Arg} \left( \frac{i}{-1-i} \right) = \frac{5\pi}{4} + 2\pi = -\frac{3\pi}{4}$$

**Exercises 8: (visit @ Youtube “learning with Usman Hamid”)**

1. Find the principal argument  $\text{Arg } z$  when

i.  $z = \frac{-2}{1+\sqrt{3}i}$

ii.  $z = (\sqrt{3} - i)^6$

2. Find the modulus and argument of the followings

i.  $z = \frac{1+2i}{1-(1-i)^2}$

ii.  $z = \frac{3-i}{2+i} + \frac{3+i}{2-i}$

3. Show that (a)  $|e^{i\theta}| = 1$ ; (b)  $e^{i\theta} = e^{-i\theta}$ .

4. Use mathematical induction to show that

$$e^{i\theta_1} e^{i\theta_2} \dots e^{i\theta_n} = e^{i(\theta_1 + \theta_2 + \dots + \theta_n)} \quad (n = 2, 3, \dots).$$

5. Using the fact that the modulus  $|e^{i\theta} - 1|$  is the distance between the points  $e^{i\theta}$  and 1 give a geometric argument to find a value of  $\theta$  in the interval  $0 \leq \theta < 2\pi$  that satisfies the equation  $|e^{i\theta} - 1| = 2$  **Ans:  $\pi$**

**MISCELLANEOUS PROBLEMS**

**Example:** Find the locus of 'z' when  $\text{arg} \left( \frac{z-1}{z+1} \right) = \frac{\pi}{3}$

**Solution:** consider  $\frac{z-1}{z+1} = \frac{x+iy-1}{x+iy+1} = \frac{(x-1)+iy}{(x+1)+iy} = \frac{x^2+y^2-1}{(x^2+1)^2+y^2} + i \frac{2y}{(x^2+1)^2+y^2}$

$$\Rightarrow \text{arg} \left( \frac{z-1}{z+1} \right) = \text{Tan}^{-1} \left( \frac{2y}{x^2 + y^2 - 1} \right)$$

$$\Rightarrow \frac{\pi}{3} = \text{Tan}^{-1} \left( \frac{2y}{x^2 + y^2 - 1} \right) \Rightarrow \text{Tan} \left( \frac{\pi}{3} \right) = \frac{2y}{x^2 + y^2 - 1}$$

$$\Rightarrow \sqrt{3} = \frac{2y}{x^2 + y^2 - 1} \Rightarrow x^2 + y^2 - \frac{2}{\sqrt{3}}y - 1 = 0 \text{ an equation of circle.}$$

**Example:** Find the locus of 'z' when  $\left| \frac{z-i}{z+i} \right| \geq 2 \Rightarrow \left| \frac{z-i}{z+i} \right|^2 \geq 4$

**Solution:** Since  $|z|^2 = z\bar{z}$  therefore

$$\left| \frac{z-i}{z+i} \right|^2 \geq 4 \Rightarrow \left( \frac{z-i}{z+i} \right) \overline{\left( \frac{z-i}{z+i} \right)} \geq 4 \Rightarrow \left( \frac{z-i}{z+i} \right) \left( \frac{\bar{z}-i}{\bar{z}+i} \right) \geq 4$$

$$\Rightarrow 4|z|^2 + 4i(\bar{z}-z) + 4 - |z|^2 + i(\bar{z}-z) - 1 \leq 0$$

$$\Rightarrow 3|z|^2 + 5i(\bar{z}-z) + 3 \leq 0 \Rightarrow 3(x^2 + y^2) + 5i(-2iy) + 3 \leq 0$$

$$\Rightarrow 3x^2 + 3y^2 + 10y + 3 \leq 0 \text{ which is interior and boundary of circle.}$$

**Example:** Prove that  $\left| \frac{az+b}{b\bar{z}+a} \right| = 1$  for  $|z| = 1$

**Solution:** Since  $|z| = 1 \Rightarrow |z|^2 = 1 = z\bar{z} \Rightarrow \bar{z} = \frac{1}{z}$  then

$$\left| \frac{az+b}{b\bar{z}+a} \right| = \left| \frac{az+b}{\frac{b}{z}+a} \right| = \left| \frac{az+b}{az+b} \cdot z \right| = |z| = 1 \text{ as required.}$$

**Example:** if  $z = \frac{(1+it)^2-it}{1+t^2}$  then prove that the locus of 'z' is an ellipse. Find the semi major and semi minor axis.

**Solution:** let  $z = x + iy \Rightarrow x + iy = \frac{(1+it)^2-it}{1+t^2} = \frac{1-t^2}{1+t^2} + i \frac{t}{1+t^2}$  then  
 $\Rightarrow x = \frac{1-t^2}{1+t^2}$  ;  $y = \frac{t}{1+t^2} \Rightarrow x^2 + 4y^2 = 1 \Rightarrow \frac{x^2}{(1)^2} + \frac{y^2}{(1/2)^2} = 1$

Hence given equation is an ellipse whose semi major and semi minor axis are 1 and  $\frac{1}{2}$  respectively.

**Example:** if  $z = \frac{(1+i)+(3+2i)t}{1+it}$  then prove that the locus of 'z' is a circle. Find the radius and center of circle. Also calculate the maximum and minimum distance of 'z' from origin.

**Solution:** let  $z = x + iy \Rightarrow x + iy = \frac{(1+i)+(3+2i)t}{1+it}$

$$\Rightarrow (1+it)(x+iy) = (1+i) + (3+2i)t$$

$$\Rightarrow (x-yt) + i(y+xt) = (1+3t) + i(1+2t)$$

Then comparing real and imaginary parts

$$\Rightarrow (x-yt) = (1+3t) \dots (i) \text{ and } (y+xt) = (1+2t) \dots (ii)$$

$$(i) \Rightarrow (x-yt) = (1+3t) \Rightarrow t = \frac{x-1}{y+3}$$

$$(ii) \Rightarrow (y+xt) = (1+2t) \Rightarrow \left[ y + x \left( \frac{x-1}{y+3} \right) \right] = \left[ 1 + 2 \left( \frac{x-1}{y+3} \right) \right]$$

$$\Rightarrow x^2 + y^2 + 3x + 2y - 1 = 0 \quad (\text{After solving})$$

Hence given equation is a circle.

Now comparing the equation with  $\Rightarrow ax^2 + by^2 + 2gx + 2fy + c = 0$

$$\text{We get } g = -\frac{3}{2}, f = 1, c = -1$$

$$\text{Thus center of circle} = (-g, -f) = \left( \frac{3}{2}, -1 \right)$$

$$\text{radius of circle} = \sqrt{f^2 + g^2 - c} = \frac{\sqrt{17}}{2}$$

$$\text{maximum distance} = OA = AC - OC = \frac{\sqrt{17}}{2} - \frac{\sqrt{13}}{2}$$

$$\text{minimum distance} = OB = BC + OC = \frac{\sqrt{17}}{2} + \frac{\sqrt{13}}{2}$$

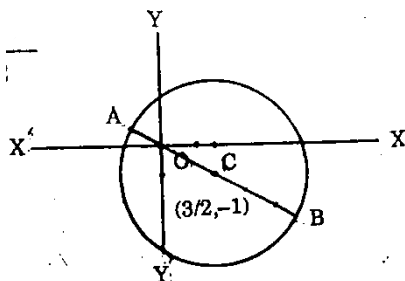

**Example:**

Prove that  $\left| \frac{a+b}{1+\bar{a}b} \right| \leq 1$  if  $|a| < 1$  and  $|b| < 1$  when does equality holds?

**Solution:** We have to prove  $\left| \frac{a+b}{1+\bar{a}b} \right| \leq 1 \Rightarrow |a+b| \leq |1+\bar{a}b|$   
if  $|a| < 1$  and  $|b| < 1$

Consider

$$|a+b|^2 = (a+b)\overline{(a+b)} = (a+b)(\bar{a}+\bar{b}) = a\bar{a} + a\bar{b} + b\bar{a} + b\bar{b}$$

$$\Rightarrow |a+b|^2 = |a|^2 + |b|^2 + a\bar{b} + \bar{a}b \dots \dots \dots (i)$$

Again Consider

$$|1+\bar{a}b|^2 = (1+\bar{a}b)\overline{(1+\bar{a}b)} = (1+\bar{a}b)(1+a\bar{b}) \quad \therefore \bar{\bar{a}} = a$$

$$\Rightarrow |1+\bar{a}b|^2 = 1 + a\bar{b} + \bar{a}b + a\bar{a}b\bar{b}$$

Adding and subtracting  $|a|^2 + |b|^2$  on R.H.S

$$\Rightarrow |1+\bar{a}b|^2 = |a|^2 + |b|^2 + a\bar{b} + \bar{a}b + 1 + a\bar{a}b\bar{b} - |a|^2 - |b|^2$$

$$\Rightarrow |1+\bar{a}b|^2 = |a+b|^2 + 1 + |a||b| - |a|^2 - |b|^2 \quad \therefore \text{using (i)}$$

$$\Rightarrow |1+\bar{a}b|^2 = |a+b|^2 + (1-|a|^2)(1-|b|^2)$$

Since  $1-|a|^2 > 0$  also  $1-|b|^2 > 0$

$$\Rightarrow |1+\bar{a}b|^2 \geq |a+b|^2 \Rightarrow |1+\bar{a}b| \geq |a+b| \Rightarrow |a+b| \leq |1+\bar{a}b|$$

Equality will hold if

$$1-|a|^2 = 0 \Rightarrow |a|^2 = 1 \Rightarrow |a| = 1 \text{ also } 1-|b|^2 = 0 \Rightarrow |b| = 1$$

**Example:**

Prove that  $|z_1+z_2|^2 + |z_1-z_2|^2 = 2[|z_1|^2 + |z_2|^2]$  and deduce the result  $|a + \sqrt{a^2 - b^2}| + |a - \sqrt{a^2 - b^2}| = |a+b| + |a-b|$

**Solution:**

$$L.H.S = |z_1+z_2|^2 + |z_1-z_2|^2$$

$$L.H.S = (z_1+z_2)\overline{(z_1+z_2)} + (z_1-z_2)\overline{(z_1-z_2)}$$

$$L.H.S = (z_1+z_2)(\bar{z}_1+\bar{z}_2) + (z_1-z_2)(\bar{z}_1-\bar{z}_2)$$

$$L.H.S = z_1\bar{z}_1 + z_1\bar{z}_2 + z_2\bar{z}_1 + z_2\bar{z}_2 + z_1\bar{z}_1 - z_1\bar{z}_2 - z_2\bar{z}_1 - z_2\bar{z}_2$$

$$L.H.S = |z_1|^2 + |z_2|^2 + |z_1|^2 + |z_2|^2 = 2[|z_1|^2 + |z_2|^2] = R.H.S$$

$$\text{Now let } z_1 = a + \sqrt{a^2 - b^2} \text{ and } z_2 = a - \sqrt{a^2 - b^2}$$

$$\text{Then } |z_1|^2 + |z_2|^2 = \frac{1}{2}[|z_1+z_2|^2 + |z_1-z_2|^2] = \frac{1}{2}[|2a|^2 + |2\sqrt{a^2 - b^2}|^2]$$

$$\Rightarrow |z_1|^2 + |z_2|^2 = 2|a|^2 + 2|a^2 - b^2| \dots \dots \dots (i)$$

$$\text{Now } [ |z_1| + |z_2| ]^2 = |z_1|^2 + |z_2|^2 + 2|z_1z_2| = 2|a|^2 + 2|a^2 - b^2| + 2|b|^2$$

$$\Rightarrow [ |z_1| + |z_2| ]^2 = [ |a+b| + |a-b| ]^2 \Rightarrow |z_1| + |z_2| = |a+b| + |a-b|$$

$$\text{Hence } |a + \sqrt{a^2 - b^2}| + |a - \sqrt{a^2 - b^2}| = |a+b| + |a-b|$$

**Example:**

Represent graphically all points for 'z' such that  $\left|\frac{z+1}{z-1}\right| = 2$  also find the centre and radius of the locus of 'z'.

**Solution:** Consider  $\left|\frac{z+1}{z-1}\right|^2 = 4 \Rightarrow \left(\frac{z+1}{z-1}\right)\overline{\left(\frac{z+1}{z-1}\right)} = 4 \Rightarrow \left(\frac{z+1}{z-1}\right)\left(\frac{\bar{z}+1}{\bar{z}-1}\right) = 4$

$$\Rightarrow \frac{(z+1)(\bar{z}+1)}{(z-1)(\bar{z}-1)} = 4 \Rightarrow (z+1)(\bar{z}+1) = 4(z-1)(\bar{z}-1)$$

$$\Rightarrow z\bar{z} + z + \bar{z} + 1 = 4z\bar{z} - 4z - 4\bar{z} + 4 \Rightarrow 3z\bar{z} - 5(z + \bar{z}) + 3 = 0$$

$$\Rightarrow z\bar{z} - \frac{5}{3}(z + \bar{z}) + 1 = 0 \Rightarrow \left(z - \frac{5}{3}\right)\left(\bar{z} - \frac{5}{3}\right) - \frac{25}{9} + 1 = 0$$

$$\Rightarrow \left(z - \frac{5}{3}\right)\left(\bar{z} - \frac{5}{3}\right) - \frac{16}{9} = 0 \Rightarrow \left(z - \frac{5}{3}\right)\left(\bar{z} - \frac{5}{3}\right) = \frac{16}{9}$$

$$\Rightarrow \left|z - \frac{5}{3}\right|^2 = \left(\frac{4}{3}\right)^2 \text{ Represents a circle centered at } \frac{5}{3} \text{ having radius } \frac{4}{3}$$

**Example:**

Find the locus of 'z' where  $z = a\text{Cost} + b\text{Sint}$  where 't' is real parameter and a, b are complex constants.

**Solution:** Given  $z = a\text{Cost} + b\text{Sint}$

Let  $z = x + iy, a = a_1 + a_2i, b = b_1 + b_2i$  then

$$x + iy = (a_1 + a_2i)\text{Cost} + (b_1 + b_2i)\text{Sint}$$

$$x + iy = (a_1\text{Cost} + b_1\text{Sint}) + i(a_2\text{Cost} + b_2\text{Sint})$$

Then comparing real and imaginary parts

$$x = a_1\text{Cost} + b_1\text{Sint} \Rightarrow a_1\text{Cost} + b_1\text{Sint} - x = 0$$

$$y = a_2\text{Cost} + b_2\text{Sint} \Rightarrow a_2\text{Cost} + b_2\text{Sint} - y = 0$$

$$\Rightarrow \frac{\text{Cost}}{b_2x - b_1y} = \frac{\text{Sint}}{a_1y - a_2x} = \frac{1}{a_1b_2 - a_2b_1}$$

$$\Rightarrow \frac{\text{Cost}}{b_2x - b_1y} = \frac{1}{a_1b_2 - a_2b_1} \text{ and } \Rightarrow \frac{\text{Sint}}{a_1y - a_2x} = \frac{1}{a_1b_2 - a_2b_1}$$

$$\Rightarrow \text{Cost} = \frac{b_2x - b_1y}{a_1b_2 - a_2b_1} \text{ and } \Rightarrow \text{Sint} = \frac{a_1y - a_2x}{a_1b_2 - a_2b_1}$$

$$\Rightarrow \text{Cos}^2t + \text{Sin}^2t = \left(\frac{b_2x - b_1y}{a_1b_2 - a_2b_1}\right)^2 + \left(\frac{a_1y - a_2x}{a_1b_2 - a_2b_1}\right)^2$$

$$\Rightarrow 1 = \frac{(b_2x - b_1y)^2 + (a_1y - a_2x)^2}{(a_1b_2 - a_2b_1)^2}$$

$$\Rightarrow (a_1b_2 - a_2b_1)^2 = (b_2x - b_1y)^2 + (a_1y - a_2x)^2$$

$$\Rightarrow [-(a_2b_1 - a_1b_2)]^2 = b_2^2x^2 + b_1^2y^2 - 2b_1b_2xy + a_1^2y^2 + a_2^2x^2 - 2a_1a_2xy$$

$$\Rightarrow (a_2b_1 - a_1b_2) = (a_2^2 + b_2^2)x^2 + (a_1^2 + b_1^2)y^2 - 2xy(a_1a_2 + b_1b_2)$$

$$\Rightarrow [-(a_2b_1 - a_1b_2)]^2 = b_2^2x^2 + b_1^2y^2 - 2b_1b_2xy + a_1^2y^2 + a_2^2x^2 - 2a_1a_2xy$$

$$\Rightarrow (a_2b_1 - a_1b_2) = (a_2^2 + b_2^2)x^2 + (a_1^2 + b_1^2)y^2 - 2xy(a_1a_2 + b_1b_2)$$

Given equation is an ellipse because

$$(a_1a_2 + b_1b_2)^2 - (a_1^2 + b_1^2)(a_2^2 + b_2^2) < 0 \text{ (after solving)}$$

**Remark:** a curve  $ax^2 + by^2 + 2hxy + 2gx + 2fy + c = 0$  is

- an ellipse if  $h^2 - ab < 0$
- a hyperbola if  $h^2 - ab > 0$
- a parabola if  $h^2 - ab = 0$

**Example:**

Prove that  $||z_1| - |z_2|| \leq |z_1 + z_2| \leq |z_1| + |z_2|$

**Proof:**

$$\begin{aligned} \text{consider } z_1 &= (z_1 + z_2) - z_2 \Rightarrow |z_1| = |(z_1 + z_2) - z_2| \\ &\Rightarrow |z_1| \leq |z_1 + z_2| + |-z_2| \Rightarrow |z_1| - |z_2| \leq |z_1 + z_2| \dots \dots (A) \end{aligned}$$

$$\begin{aligned} \text{Similarly } z_2 &= (z_2 + z_1) - z_1 \Rightarrow |z_2| = |(z_2 + z_1) - z_1| \\ &\Rightarrow |z_2| \leq |z_2 + z_1| + |-z_1| \Rightarrow |z_2| - |z_1| \leq |z_1 + z_2| \\ &\Rightarrow -[|z_1| - |z_2|] \leq |z_1 + z_2| \Rightarrow |z_1| - |z_2| \geq -|z_1 + z_2| \dots \dots (B) \end{aligned}$$

From (A) and (B)  $||z_1| - |z_2|| \leq |z_1 + z_2| \dots \dots (i)$

Also  $|z_1 + z_2| \leq |z_1| + |z_2| \dots \dots (ii)$

From (i) and (ii)  $||z_1| - |z_2|| \leq |z_1 + z_2| \leq |z_1| + |z_2| \dots \dots (iii)$

This is our required result.

Further (**in need**) since  $|z_2| = |-z_2|$  therefore replacing in (iii)

$$\begin{aligned} ||z_1| - |-z_2|| &\leq |z_1 - z_2| \leq |z_1| + |-z_2| \\ ||z_1| - |z_2|| &\leq |z_1 - z_2| \leq |z_1| + |z_2| \dots \dots (iv) \end{aligned}$$

From (iii) and (iv)  $||z_1| - |z_2|| \leq |z_1 + z_2| \leq |z_1| + |z_2|$

**Remark:**

maximum value of  $|z_1 + z_2| = |z_1| + |z_2|$

minimum value of  $|z_1 + z_2| = ||z_1| - |z_2||$

**Example:**

Find maximum and minimum of  $|z_1 + z_2|$  for a unit circle. i.e.  $|z| = 1$

**Solution:**

maximum value of  $|z_1 + z_2| = |z_1| + |z_2| = |1| + |1| = 1 + 1 = 2$

minimum value of  $|z_1 + z_2| = ||z_1| - |z_2|| = ||1| - |1|| = |1 - 1| = 0$

**Exercise 9: (visit @ Youtube “learning with Usman Hamid”)**

1. Find the locus of ‘z’ when  $\left| \frac{z-i}{z+i} \right| \leq 2 \Rightarrow \left| \frac{z-i}{z+i} \right|^2 \leq 4$
2. Prove that  $\left| \frac{a-b}{1-\bar{a}b} \right| \leq 1$  if  $|a| < 1$  and  $|b| < 1$  when does equality holds?
3. Prove that  $\left| \frac{a-b}{1-\bar{a}b} \right| < 1$  if either  $|a| = 1$  or  $|b| = 1$  what exception must be made if  $|a| = |b| = 1$
4. Prove that  $|a + b|^2 + |a - b|^2 = 2[|a|^2 + |b|^2]$  where ‘a’ and ‘b’ being any complex numbers.
5. Find the locus of ‘z’ where  $z = at + \frac{b}{t}$  where ‘t’ is real parameter and a , b are complex constants.
6. Find maximum and minimum of  $|z_1 + z_2|$  for  $|z - 2|$  and  $|z - (3 + i)|$



## ROOTS OF COMPLEX NUMBERS

A number ' $c_k$ ' is called an  $n$ th root of a complex number ' $z$ ' if  $(c_k)^n = z$  and we write

$$c_k = z^{1/n} = \sqrt[n]{z} = |z|^{1/n} \left[ \cos\left(\frac{\theta+2k\pi}{n}\right) + i\sin\left(\frac{\theta+2k\pi}{n}\right) \right] = r^{1/n} e^{i\left(\frac{\theta+2k\pi}{n}\right)}$$

Where  $k = 0, 1, 2, 3, \dots, n-1$

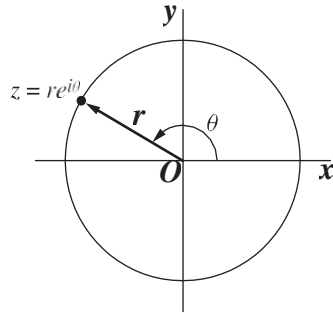

**Note:** we may use  $w_n^k = e^{i\left(\frac{2k\pi}{n}\right)}$  and use formula  $c_k = c_0 w_n^k$  to Write roots symbolically.

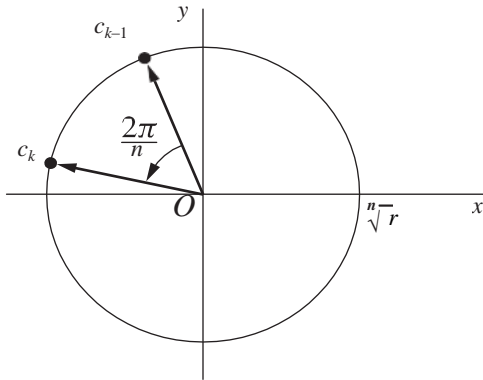

**Question:** Write  $2 + 2\sqrt{3}i$  into polar form.

**Solution:** Let  $z = 2 + 2\sqrt{3}i \Rightarrow |z| = r = 4$  and  $\theta = \frac{\pi}{3}$

then polar form will be  $z = re^{i\theta} = 4e^{i\frac{\pi}{3}} = 4\text{CiS}\frac{\pi}{3}$

### HOW TO FIND $n^{\text{th}}$ ROOTS OF COMPLEX NUMBERS?

- i. Write complex number into polar form.
- ii. Use formula

$$c_k = z^{1/n} = \sqrt[n]{z} = |z|^{\frac{1}{n}} \left[ \text{Cos} \left( \frac{\theta + 2k\pi}{n} \right) + i \text{Sin} \left( \frac{\theta + 2k\pi}{n} \right) \right] = r^{\frac{1}{n}} e^{i \left( \frac{\theta + 2k\pi}{n} \right)}$$

Where  $k = 0, 1, 2, 3, \dots, n - 1$

**Example:** Find all values of  $(-16)^{1/4}$ , or all of the fourth roots of the number  $-16$ .

**Solution:** Let  $z = -16 = -16 + 0i \Rightarrow |z| = r = 16$  and  $\theta = \pi$   
then polar form will be  $z = -16 = re^{i\theta} = 16e^{i(\pi + 2k\pi)}$

Where  $k = 0, \pm 1, \pm 2, \dots, n - 1$

now to find desired root we use the formula and  $k = 0, 1, 2, 3$

then  $c_k = (-16)^{1/4} = |16|^{1/4} e^{i \left( \frac{\pi + 2k\pi}{4} \right)} = 2e^{i \left( \frac{\pi}{4} + \frac{k\pi}{2} \right)}$ ;  $k = 0, 1, 2, 3$

put  $k = 0 \Rightarrow c_0 = 2e^{i \left( \frac{\pi}{4} \right)} = 2 \left[ \text{Cos} \left( \frac{\pi}{4} \right) + i \text{Sin} \left( \frac{\pi}{4} \right) \right] = 2 \left[ \frac{1}{\sqrt{2}} + i \frac{1}{\sqrt{2}} \right]$

$\Rightarrow c_0 = \sqrt{2}(1 + i)$

put  $k = 1 \Rightarrow c_1 = 2e^{i \left( \frac{\pi}{4} + \frac{\pi}{2} \right)} = 2e^{i \left( \frac{3\pi}{4} \right)} = \sqrt{2}(-1 + i)$

put  $k = 2 \Rightarrow c_2 = 2e^{i \left( \frac{\pi}{4} + \frac{2\pi}{2} \right)} = 2e^{i \left( \frac{5\pi}{4} \right)} = \sqrt{2}(-1 - i)$

put  $k = 3 \Rightarrow c_3 = 2e^{i \left( \frac{\pi}{4} + \frac{3\pi}{2} \right)} = 2e^{i \left( \frac{7\pi}{4} \right)} = \sqrt{2}(1 - i)$

hence  $c_0, c_1, c_2, c_3$  are our required fourth roots of the number  $-16$ .

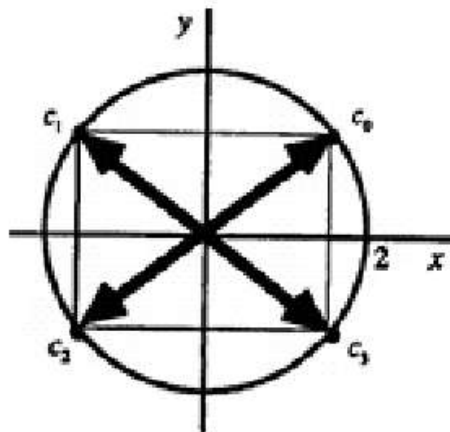

**Example:** If  $1 = 1 \exp[i(0+2k\pi)]$  ( $k = 0, \pm 1, \pm 2 \dots$ ) then find the square root of unity.

**Solution:** Let  $z = 1 = 1 + 0i \Rightarrow |z| = r = 1$  and  $\theta = 0$

then polar form will be  $z = 1 = r e^{i\theta} = 1 e^{i(0+2k\pi)}$

Where  $k = 0, 1, \pm 2, \dots, n-1$

now to find desired root we use the formula and  $k = 0, 1$

then  $c_k = (1)^{1/2} = |1|^{1/2} e^{i(\frac{0+2k\pi}{2})} = e^{i(k\pi)}$  ;  $k = 0, 1$

put  $k = 0 \Rightarrow c_0 = e^{i(0)} = [\cos(0) + i\sin(0)] = 1 \Rightarrow c_0 = 1$

put  $k = 1 \Rightarrow c_1 = e^{i(\pi)} = [\cos(\pi) + i\sin(\pi)] = -1$

hence  $c_0, c_1$  are our required square root of the unity.

**Example:** If  $z = a + i$  then find the square root of  $z$ .

**Solution:** Let  $z = a + i \Rightarrow A$  (say)  $= |z| = r = |a + i| = 1\sqrt{a^2 + 1}$   
and  $\alpha = \text{Arg}(a + i)$

then polar form will be  $z = r e^{i\theta} \Rightarrow a + i = A e^{i(\alpha+2k\pi)}$

Where  $k = 0, \pm 1, \pm 2, \dots, n-1$

now to find desired root we use the formula and  $k = 0, 1$

then  $c_k = (a + i)^{1/2} = \sqrt{A} e^{i(\frac{\alpha}{2} + k\pi)}$  ;  $k = 0, 1$

put  $k = 0 \Rightarrow c_0 = \sqrt{A} e^{i(\frac{\alpha}{2})} \Rightarrow c_0 = \sqrt{A} e^{i(\frac{\alpha}{2})}$

$k = 1 \Rightarrow c_1 = \sqrt{A} e^{i(\frac{\alpha}{2} + \pi)} = \sqrt{A} e^{i(\frac{\alpha}{2})} e^{i(\pi)} = -\sqrt{A} e^{i(\frac{\alpha}{2})} \Rightarrow c_1 = -c_0$

Now Euler's formula tells us that  $c_0 = \sqrt{A} \left[ \cos\left(\frac{\alpha}{2}\right) + i\sin\left(\frac{\alpha}{2}\right) \right]$

Because  $(a + i)$  lies above the real axis and we know that  $0 < \alpha < \pi$  so

$\cos\left(\frac{\alpha}{2}\right) > 0$  and  $\sin\left(\frac{\alpha}{2}\right) > 0$

also we know  $\cos^2\left(\frac{\alpha}{2}\right) = \frac{1+\cos\alpha}{2}$  and  $\sin^2\left(\frac{\alpha}{2}\right) = \frac{1-\cos\alpha}{2}$

$$\Rightarrow c_0 = \sqrt{A} \left[ \sqrt{\frac{1+\cos\alpha}{2}} + i\sqrt{\frac{1-\cos\alpha}{2}} \right]$$

But by direction cosine  $\cos \alpha = \frac{a}{A}$  therefore

$$\sqrt{\frac{1 \pm \cos\alpha}{2}} = \sqrt{\frac{1 \pm \left(\frac{a}{A}\right)}{2}} = \sqrt{\frac{A \pm a}{2A}}$$

Consequently by using above relation and  $c_1 = -c_0$  that the two square roots of  $(a + i)$  are  $\pm \frac{1}{\sqrt{2}} (\sqrt{A+a} + i\sqrt{A-a})$

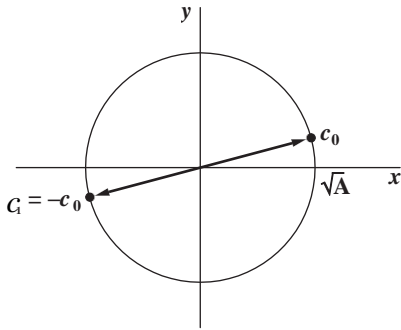

**Exercises 10:** (visit @ Youtube “learning with Usman Hamid”)

1. Write in polar form.  $-\sqrt{3} - i$
2. Compute  $z^3$  for  $z = -\sqrt{3} - i$
3. Find the square roots of  $2i$ ,  $1 - \sqrt{3}i$  and express them in rectangular coordinates.
4. Find three cube roots of  $z = i$
5. Find the four fourth roots of  $z = 1 + i$
6. Find the three cube roots of  $-8i$  and express them in rectangular coordinates and sketch.
7. Find  $(-8 - 8i)^{1/4}$ ,  $(-1)^{1/3}$ ,  $(-1 + i)^{1/3}$ ,  $(8)^{1/6}$  and express them in rectangular coordinates and sketch and identify principal root.
8. Compute the roots of  $[(-1 + i)/i]^{1/4}$  and sketch them.

---

## REGIONS IN THE COMPLEX PLANE

---

**SET OF POINTS (POINT SET):** Any collection of points in the complex plane (2 – dimensional) is called a point set and each point is called a member or element of the set

**NEIGHBORHOOD:** An  $\varepsilon$  neighborhood  $|z - z_0| < \varepsilon$  of a given point  $z_0$ . consists of all points  $z$  lying inside but not on a circle centered at  $z_0$  and with a specified positive radius  $\varepsilon$  (Fig.).

**DELETED NEIGHBORHOOD:** a *deleted neighborhood*, or punctured disk,  $0 < |z - z_0| < \varepsilon$  consisting of all points  $z$  in an  $\varepsilon$  neighborhood of  $z_0$  except for the point  $z_0$  itself.

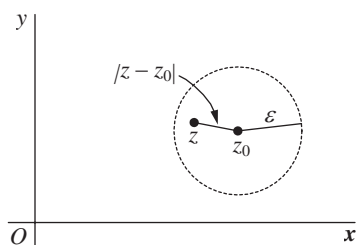

**INTERIOR POINT:** A point  $z_0$  is said to be an *interior point* of a set  $S$  whenever there is some neighborhood of  $z_0$  that contains only points of  $S$ .

**EXTERIOR POINT:** A point  $z_0$  is said to be an *exterior point* of a set  $S$  whenever there is some neighborhood of  $z_0$  that contains no points of  $S$ .

**BOUNDARY POINT:** A point  $z_0$  is said to be a *boundary point* of a set  $S$  whenever there is some neighborhood of  $z_0$  that contains points belong to  $S$  and points not belong to  $S$ .

The circle  $|z| = 1$  for instance, is the boundary of each of the sets  $|z| < 1$  and  $|z| \leq 1$ .

**OPEN SET:** A set is *open* if it contains none of its boundary points. For example  $|z| < 1$

**CLOSE SET:** A set is *closed* if it contains all of its boundary points, and the *closure* of a set  $S$  is the closed set consisting of all points in  $S$  together with the boundary of  $S$ . For example  $|z| \leq 1$

**NOTE:** the punctured disk  $0 < |z| \leq 1$  is neither open nor closed. The set of all complex numbers is, on the other hand, both open and closed since it has no boundary points.

**CONNECTED SET:** An open set  $S$  is *connected* if each pair of points  $z_1$  and  $z_2$  in it can be joined by a *polygonal line*, consisting of a finite number of line segments joined end to end, that lies entirely in  $S$ . The open set  $|z| < 1$  is connected. The annulus  $1 < |z| < 2$  is, of course, open and it is also connected (see Fig).

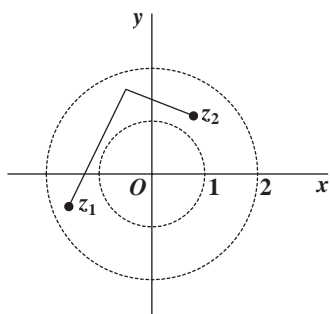

**DOMAIN:** A nonempty open set that is connected is called a *domain*. Note that any neighborhood is a domain.

**REGION:** A domain together with some, none, or all of its boundary points is referred to as a *region*.

**BOUNDED SET:** A set  $S$  is *bounded* if every point of  $S$  lies inside some circle  $|z| = R$ ; otherwise, it is *unbounded*. Both of the sets  $|z| < 1$  and  $|z| \leq 1$  are bounded regions, and the half plane  $\operatorname{Re} z \geq 0$  is unbounded.

**ACCUMULATION POINT:** A point  $z_0$  is said to be an *accumulation point* of a set  $S$  if each deleted neighborhood of  $z_0$  contains at least one point of  $S$ . It follows that if a set  $S$  is closed, then it contains each of its accumulation points. For if an accumulation point  $z_0$  were not in  $S$ , it would be a boundary point of  $S$ ; but this contradicts the fact that a closed set contains all of its boundary points. Thus a set is closed if and only if it contains all of its accumulation points.

Evidently, a point  $z_0$  is *not* an accumulation point of a set  $S$  whenever there exists some deleted neighborhood of  $z_0$  that does not contain at least one point of  $S$ . Note that the origin is the only accumulation point of the set  $z_n = i/n$  ( $n = 1, 2, \dots$ ).

**Example:** Sketch the set  $\text{Im} \left( \frac{1}{z} \right) > 1$

**Solution:** Let for  $z \neq 0$ ;  $\frac{1}{z} = \frac{\bar{z}}{z\bar{z}} = \frac{\bar{z}}{|z|^2} = \frac{x-iy}{x^2+y^2}$

$$\Rightarrow \text{Im} \left( \frac{1}{z} \right) = \frac{-y}{x^2+y^2} > 1 \Rightarrow x^2 + y^2 + y < 0$$

$$\Rightarrow x^2 + \left( y^2 + y + \frac{1}{4} \right) < \frac{1}{4} \Rightarrow (x-0)^2 + \left( y + \frac{1}{2} \right)^2 < \left( \frac{1}{2} \right)^2$$

$$\Rightarrow \left| z - \left( -\frac{i}{2} \right) \right| = \frac{1}{2} \text{ Represents the region interior to the circle}$$

Centered at  $z_0 = -\frac{i}{2}$  with radius  $\frac{1}{2}$

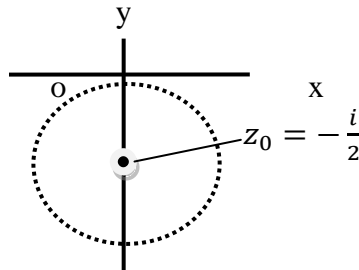

**Exercises 11: (visit @ Youtube “learning with Usman Hamid”)**

1. Sketch the following sets and determine which are domains. Also show either sets are open or closed. Also show sets are either bounded or not.

- (a)  $|z - 2 + i| \leq 1$ ;                      (b)  $|2z + 3| > 4$ ;  
 (c)  $\text{Im } z > 1$ ;                              (d)  $\text{Im } z = 1$ ;  
 (e)  $0 \leq \arg z \leq \pi/4$  ( $z \neq 0$ )      (f)  $|z - 4| \geq |z|$ .  
 (g) Whether the set  $-1 \leq \text{Im } z < 4$  is closed?

2. In each case, sketch the closure of the set:

- i.  $-\pi < \arg z < \pi$  ( $z \neq 0$ )  
 ii.  $|\text{Re}(z)| < |z|$   
 iii.  $\text{Re} \left( \frac{1}{z} \right) \leq \frac{1}{2}$   
 iv.  $\text{Re}(z^2) > 0$

3. Let  $S$  be the open set consisting of all points  $z$  such that  $|z| < 1$  or  $|z-2| < 1$ . State why  $S$  is not connected

## FUNCTIONS OF A COMPLEX VARIABLE

Let  $S$  be a set of complex numbers. A *function*  $f$  defined on  $S$  is a rule that assigns to each  $z$  in  $S$  a complex number  $w$ .

The number  $w$  is called the *value* of  $f$  at  $z$  and is denoted by  $f(z)$ ; that is  $w = f(z)$ . The set  $S$  is called the *domain of definition* of  $f$ .

**OR** If a relation between two complex variables 'w' and 'z' is such that given a value of 'z' there corresponds a unique value of 'w' then 'w' is said to be a function of 'z' and is usually denoted by  $w = f(z)$  and it is a Single valued function of 'z'.

For  $w = f(z)$ , 'w' is called range and a dependent variable, while 'z' is Independent variable.

**OR** A function whose domain and range are subsets of the set  $C$  of complex numbers is called a **complex function**.

**Remark:** It must be emphasized that both a domain of definition and a rule are needed in order for a function to be well defined. When the domain of definition is not mentioned, we agree that the largest possible set is to be taken. Also, it is not always convenient to use notation that distinguishes between a given function and its values.

**SINGLE VALUED FUNCTIONS:** For a given complex valued function  $w = f(z)$  If only one value of 'w' corresponds to each value of 'z', then we say that 'w' is a Single valued function of 'z' **OR** that  $w = f(z)$  is single valued.  
**For example**  $f(z) = z^2$  is single valued function.

**MULTI VALUED FUNCTIONS:** For a given complex valued function  $w = f(z)$  If more than one value of 'w' corresponds to each value of 'z', then we say that 'w' is a multi-valued function of 'z' **OR** that  $w = f(z)$  is multi valued.  
**For example**  $f(z) = \sqrt{z}$  is two valued function.  
Also  $f(z) = \sqrt[n]{z}$  is n - valued function.

**Remark:**

- $\sqrt{z} = \pm\sqrt{re^{i\theta/2}}$  is double valued and  $\sqrt{z} = \sqrt{re^{i\theta/2}}$  is single valued.
- Whenever we speak of function, we shall, unless otherwise stated, assume Single valued.
- A multivalued function can be considered as a collection of single valued Functions, each member of which is called a **branch** of the function.

It is customary to consider one particular member as a **Principal Branch** Of the multivalued function and the value of the function corresponding to This branch is the Principle value.



**TRANSFORMATION:**

Suppose that  $w = u + iv$  is a single valued function  $f$  at  $z = x + iy$ , so that  $u + iv = f(x + iy)$ . Each of the real numbers  $u$  and  $v$  depends on the real variables  $x$  and  $y$ , and it follows that  $f(z)$  can be expressed in terms of a pair of real-valued functions of the real variables  $x$  and  $y$ :  $f(z) = u(x, y) + iv(x, y)$ . Then equating we get  $u = u(x, y)$ ,  $v = v(x, y)$  thus a given point  $P(x, y)$  in  $z$  - plane correspond a point  $P'(u, v)$  in  $w$  - plane and for  $w = f(z)$  the set  $u = u(x, y)$ ,  $v = v(x, y)$  is called transformation and we say that point  $P$  is mapped or transformed into  $P'$  by means of transformation and  $P'$  will called image of  $P$

If the polar coordinates  $r$  and  $\theta$ , instead of  $x$  and  $y$ , are used, then  $u + iv = f(re^{i\theta})$  where  $w = u + iv$  and  $z = re^{i\theta}$ . In that case, we may write  $f(z) = u(r, \theta) + iv(r, \theta)$ .

**Example:** Write transformation of  $f(z) = z^2$ .

**Solution:** Given  $W = f(z) = z^2$ .

$$\Rightarrow u + iv = (x + iy)^2 = x^2 + y^2 + 2xyi$$

$$\Rightarrow u = u(x, y) = x^2 + y^2, v = v(x, y) = 2xy \text{ Required.}$$

**Example:** Similarly A real-valued function  $f(z) = |z|^2 = x^2 + y^2 + i0$

**Example:** Write transformation of  $f(z) = z^2$  in polar form.

**Solution:** Given  $W = f(z) = z^2$ .

$$\Rightarrow u + iv = (re^{i\theta})^2 = r^2 e^{2i\theta} = r^2 \cos 2\theta + ir^2 \sin 2\theta$$

$$\Rightarrow u = u(r, \theta) = r^2 \cos 2\theta, v = v(r, \theta) = r^2 \sin 2\theta \text{ Required.}$$

**Polynomial:** If  $n$  is zero or a positive integer and if  $a_0, a_1, a_2, \dots, a_n$  are complex constants, where  $a_n \neq 0$ , the function

$$P(z) = a_0 + a_1 z + a_2 z^2 + \dots + a_n z^n$$

is a **polynomial** of degree  $n$ . Note that the sum here has a finite number of terms and that the domain of definition is the entire  $z$  plane.

**Rational Functions:** Functions are defined by  $w = \frac{P(z)}{Q(z)}$

where  $P(z), Q(z)$  are polynomials and  $Q(z) \neq 0$ . Polynomials and rational functions constitute elementary, but important, classes of functions of a complex variable.

**Exercise 12: (visit @ Youtube “learning with Usman Hamid”)**

- 1) For each of the function below, describe the domain of definition That is understood.

i.  $f(z) = \frac{1}{z^2+1}$

iv.  $f(z) = \frac{1}{1-|z|^2}$

ii.  $f(z) = \text{Arg}\left(\frac{1}{z}\right)$

iii.  $f(z) = \frac{z}{z+\bar{z}}$

- 2) Transform in Cartesian form that is in form of

$$f(z) = u(x, y) + iv(x, y)$$

i.  $f(z) = z^3 + z + 1$

ii.  $f(z) = \frac{\bar{z}^2}{z} ; z \neq 0$

- 3) Transform in term of ‘z’ if  $f(z) = x^2 - y^2 - 2y + i(2x - 2xy)$

- 4) Transform in polar form if  $f(z) = z + \frac{1}{z}$

**LIMITS**

Let a function  $f$  be defined at all points  $z$  in some deleted neighborhood of  $z_0$ . The statement that the *limit* of  $f(z)$  as  $z$  approaches  $z_0$  is a number  $w_0$  or that  $\lim_{z \rightarrow z_0} f(z) = w_0$

means that the point  $w = f(z)$  can be made arbitrarily close to  $w_0$  if we choose the point  $z$  close enough to  $z_0$  but distinct from it.

 **$\epsilon, \delta$  FORM**

Statement  $\lim_{z \rightarrow z_0} f(z) = w_0$  means that for each positive number  $\epsilon$ , there is a positive number  $\delta$  such that  $|f(z) - w_0| < \epsilon$  whenever  $0 < |z - z_0| < \delta$ .

**Geometrically**, this definition says that for each  $\epsilon$  neighborhood

$|w - w_0| < \epsilon$  of  $w_0$ , there is a deleted  $\delta$  neighborhood  $0 < |z - z_0| < \delta$  of  $z_0$  such that every point  $z$  in it has an image  $w$  lying in the  $\epsilon$  neighborhood (Fig).

**Note** that even though all points in the deleted neighborhood  $0 < |z - z_0| < \delta$  are to be considered, their images need not fill up the entire neighborhood  $|w - w_0| < \epsilon$ . If  $f$  has the constant value  $w_0$ , for instance, the image of  $z$  is always the center of that neighborhood.

Note, too, that once a  $\delta$  has been found, it can be replaced by any smaller positive number, such as  $\delta/2$ .

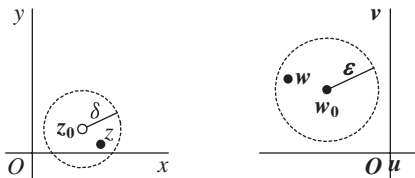

**Theorem:** when a limit of a function  $f(z)$  exists at a point  $z_0$ , it is unique.

**Proof:** Suppose that limit is not unique. i.e.

$$\lim_{z \rightarrow z_0} f(z) = w_0 \text{ and } \lim_{z \rightarrow z_0} f(z) = w_1$$

Then, for each positive number  $\varepsilon$ , there are positive numbers  $\delta_0$  and  $\delta_1$  such that

$$|f(z) - w_0| < \frac{\varepsilon}{2} \text{ whenever } 0 < |z - z_0| < \delta_0$$

$$|f(z) - w_1| < \frac{\varepsilon}{2} \text{ whenever } 0 < |z - z_0| < \delta_1.$$

Since by triangular inequality and if  $0 < |z - z_0| < \delta$  where  $\delta$  is a positive number smaller than  $\delta_0$  and  $\delta_1$

$$|w_1 - w_0| = |[f(z) - w_0] - [f(z) - w_1]| \leq |f(z) - w_0| + |f(z) - w_1| < \frac{\varepsilon}{2} + \frac{\varepsilon}{2} = \varepsilon.$$

$$|w_1 - w_0| < \varepsilon.$$

But  $|w_1 - w_0|$  is a nonnegative constant, and  $\varepsilon$  can be chosen arbitrarily small.

Hence  $|w_1 - w_0| = 0$ , or  $w_1 = w_0$  shows that limit is unique.

**Example:** Show that  $\lim_{z \rightarrow 1} f(z) = \frac{i}{2}$  for  $f(z) = \frac{i\bar{z}}{2}$  in the open disk  $|z| < 1$

**Solution:** let  $|f(z) - \frac{i}{2}| = \left| \frac{i\bar{z}}{2} - \frac{i}{2} \right| = \frac{|z-1|}{2} < 2\varepsilon \quad \therefore |z| < 1 \Rightarrow |z-1| < 2\varepsilon$

Hence for any 'z' and each positive number  $\varepsilon$  we have

$$|f(z) - \frac{i}{2}| < \varepsilon \text{ whenever } 0 < |z - 1| < 2\varepsilon$$

Thus condition is satisfied by points in the region  $|z| < 1$  when  $\delta = 2\varepsilon$  or any smaller positive number.

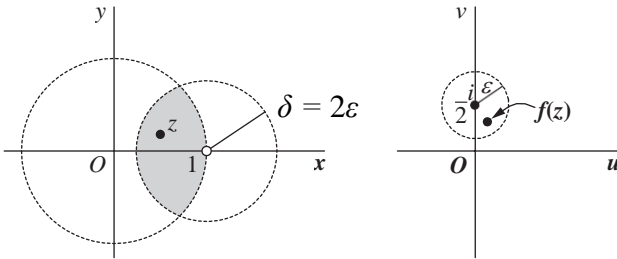

If limit  $\lim_{z \rightarrow z_0} f(z) = w_0$  exists, the symbol  $z \rightarrow z_0$  implies that  $z$  is allowed to approach  $z_0$  in an arbitrary manner, not just from some particular direction. The next example emphasizes this.

**Example:** Show that  $\lim_{z \rightarrow 0} f(z)$  does not exist for  $f(z) = \frac{z}{\bar{z}}$

**Solution:** Given  $f(z) = \frac{z}{\bar{z}} = \frac{x+iy}{x-iy}$

let we move along horizontal axis i.e.  $x \rightarrow 0$  and  $y = 0$

$$\text{Hence } \lim_{x \rightarrow 0} f(z) = \lim_{x \rightarrow 0} \frac{x+iy}{x-iy} = \frac{x+0}{x-0} = 1$$

let we move along vertical axis i.e.  $y \rightarrow 0$  and  $x = 0$

$$\text{Hence } \lim_{y \rightarrow 0} f(z) = \lim_{y \rightarrow 0} \frac{x+iy}{x-iy} = \frac{0+iy}{0-iy} = -1$$

Since limit is not unique. It does not exist.

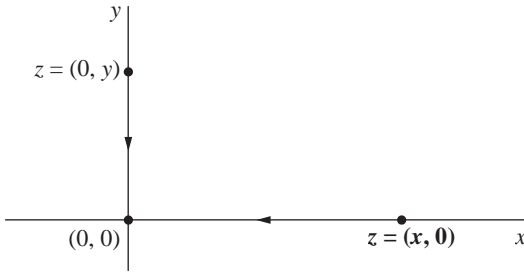

**Theorem:** Prove that  $\lim_{z \rightarrow z_0} f(z) = w_0$  exists if and only if

$\lim_{(x,y) \rightarrow (x_0,y_0)} u(x,y) = u_0$  and  $\lim_{(x,y) \rightarrow (x_0,y_0)} v(x,y) = v_0$  exist.

**Proof:** Suppose that  $\lim_{z \rightarrow z_0} f(z) = w_0$  exist then for each positive number  $\epsilon$  there exists positive numbers  $\delta$  Such that

$$|(u + iv) - (u_0 + iv_0)| < \epsilon \text{ whenever } 0 < |(x + iy) - (x_0 + iy_0)| < \delta$$

$$\text{But } |u - u_0| < |(u - u_0) + i(v - v_0)| \leq |u - u_0| + |v - v_0|$$

$$|u - u_0| = |(u + iv) - (u_0 + iv_0)| < \epsilon$$

$$\text{And } |v - v_0| < |(u - u_0) + i(v - v_0)| \leq |u - u_0| + |v - v_0|$$

$$|v - v_0| = |(u + iv) - (u_0 + iv_0)| < \epsilon$$

$$\text{Whenever } 0 < |z - z_0| < \delta$$

Hence  $\lim_{(x,y) \rightarrow (x_0,y_0)} u(x,y) = u_0$  and  $\lim_{(x,y) \rightarrow (x_0,y_0)} v(x,y) = v_0$  exists.

**Conversely:** Suppose that  $\lim_{(x,y) \rightarrow (x_0,y_0)} u(x,y) = u_0$  and

$\lim_{(x,y) \rightarrow (x_0,y_0)} v(x,y) = v_0$  Exist then for each positive number  $\epsilon$  there exist positive numbers  $\delta_1$  and  $\delta_2$  Such that

$$|u - u_0| < \frac{\epsilon}{2} \text{ Whenever } 0 < \sqrt{(x - x_0)^2 + (y - y_0)^2} < \delta_1$$

$$|v - v_0| < \frac{\epsilon}{2} \text{ Whenever } 0 < \sqrt{(x - x_0)^2 + (y - y_0)^2} < \delta_2$$

Let  $\delta = \min(\delta_1, \delta_2)$  then consider

$$|(u + iv) - (u_0 + iv_0)| = |(u - u_0) + i(v - v_0)| \leq |u - u_0| + |v - v_0|$$

$$|(u + iv) - (u_0 + iv_0)| \leq |u - u_0| + |v - v_0| < \frac{\epsilon}{2} + \frac{\epsilon}{2} = \epsilon$$

$$|(u + iv) - (u_0 + iv_0)| < \epsilon \text{ whenever } 0 < |(x + iy) - (x_0 + iy_0)| < \delta$$

$|f(z) - w_0| < \epsilon$  whenever  $0 < |z - z_0| < \delta$  Thus  $\lim_{z \rightarrow z_0} f(z) = w_0$  exists

**Theorem:** Suppose that  $\lim_{z \rightarrow z_0} f(z) = w_0$  and  $\lim_{z \rightarrow z_0} F(z) = W_0$  exist  
Then show that  $\lim_{z \rightarrow z_0} [f(z) \cdot F(z)] = [w_0 \cdot W_0]$

**Proof:** Suppose that  $\lim_{z \rightarrow z_0} [f(z) \cdot F(z)]$

And  $u(x, y) = u$  and  $v(x, y) = v$  Also  $U = U(x, y)$  and  $V = V(x, y)$  then

$$f(z) \cdot F(z) = [(u + iv) \cdot (U + iV)] = [(uU + vV) + i(vU + uV)]$$

$$\Rightarrow \lim_{(x,y) \rightarrow (x_0,y_0)} [(uU + vV) + i(vU + uV)]$$

$$= [(u_0U_0 + v_0V_0) + i(v_0U_0 + u_0V_0)] = (u_0 + iv_0)(U_0 + iV_0) = w_0 \cdot W_0$$

Thus  $\lim_{z \rightarrow z_0} [f(z) \cdot F(z)] = [w_0 \cdot W_0]$

**Theorem:** Suppose that  $\lim_{z \rightarrow z_0} f(z) = w_0$  and  $\lim_{z \rightarrow z_0} F(z) = W_0$  exist

Then show that  $\lim_{z \rightarrow z_0} \frac{f(z)}{F(z)} = \frac{w_0}{W_0}$

**Proof:** Suppose that  $\lim_{z \rightarrow z_0} [f(z) \cdot F(z)]$

And  $u(x, y) = u$  and  $v(x, y) = v$  Also  $U = U(x, y)$  and  $V = V(x, y)$  then

$$\frac{f(z)}{F(z)} = \frac{u+iv}{U+iV} = \frac{(u+iv) \cdot (U+iV)}{(U+iV) \cdot (U+iV)} = \frac{(uU+vV)+i(vU+uV)}{(U+iV) \cdot (U+iV)}$$

$$\Rightarrow \lim_{(x,y) \rightarrow (x_0,y_0)} \left[ \frac{(uU+vV)+i(vU+uV)}{(U+iV) \cdot (U+iV)} \right] = \frac{(u_0U_0+v_0V_0)+i(v_0U_0+u_0V_0)}{(U_0+iV_0) \cdot (U_0+iV_0)} = \frac{w_0W_0}{W_0W_0} = \frac{w_0}{W_0}$$

$$\Rightarrow \lim_{z \rightarrow z_0} \frac{f(z)}{F(z)} = \frac{w_0}{W_0}$$

**Example:** Evaluate  $\lim_{z \rightarrow 1+i} (z^2 + i)$

**Solution:** Given  $\lim_{z \rightarrow 1+i} (z^2 + i)$

$$\lim_{z \rightarrow 1+i} (z^2 + i) = \lim_{(x,y) \rightarrow (1,1)} [x^2 - y^2 + i(2xy + 1)] = 0 + 3i = 3i$$

**Example:** Prove that  $\lim_{z \rightarrow 1} \left( \frac{z^n - 1}{z - 1} \right) = n$  when 'n' is positive integer,  
when negative integer, also when a fraction.

**Solution:** When 'n' is positive integer:

$$\begin{aligned} \lim_{z \rightarrow 1} \left( \frac{z^n - 1}{z - 1} \right) &= \lim_{z \rightarrow 1} \left[ \frac{(z-1)(z^{n-1} + z^{n-2} + \dots + z + 1)}{z-1} \right] = \lim_{z \rightarrow 1} (z^{n-1} + z^{n-2} + \dots + z + 1) \\ &= \lim_{z \rightarrow 1} (z^{n-1}) + \lim_{z \rightarrow 1} (z^{n-2}) + \dots + \lim_{z \rightarrow 1} (z) + \lim_{z \rightarrow 1} (1) \\ &= 1 + 1 + 1 + \dots + 1(n - \text{time}) = n \end{aligned}$$

**When 'n' is negative integer: Put  $n = -m$**

$$\begin{aligned} \lim_{z \rightarrow 1} \left( \frac{z^n - 1}{z - 1} \right) &= \lim_{z \rightarrow 1} \left( \frac{z^{-m} - 1}{z - 1} \right) = \lim_{z \rightarrow 1} \left[ \frac{1 - z^m}{z^m(z-1)} \right] = - \lim_{z \rightarrow 1} \left( \frac{z^m - 1}{z - 1} \right) \lim_{z \rightarrow 1} \left( \frac{1}{z^m} \right) \\ &= m \cdot 1 = -m = n \end{aligned}$$

**When 'n' is a fraction: Put  $n = p/q$ ; where p,q are integers and  $q \neq 0$**

$$\lim_{z \rightarrow 1} \left( \frac{z^n - 1}{z - 1} \right) = \lim_{z \rightarrow 1} \left( \frac{z^{p/q} - 1}{z - 1} \right)$$

Put  $z^{1/q} = t \Rightarrow z^{p/q} = t^p$  and  $z = t^q$  also when  $z \rightarrow 1$  then  $t \rightarrow 1$

$$\lim_{z \rightarrow 1} \left( \frac{z^{p/q} - 1}{z - 1} \right) = \lim_{t \rightarrow 1} \left( \frac{t^p - 1}{t^q - 1} \right) = \lim_{t \rightarrow 1} \left( \frac{t^p - 1/t - 1}{t^q - 1/t - 1} \right) = \left[ \frac{\lim_{t \rightarrow 1} (t^p - 1/t - 1)}{\lim_{t \rightarrow 1} (t^q - 1/t - 1)} \right]$$

$$\lim_{z \rightarrow 1} \left( \frac{z^{p/q} - 1}{z - 1} \right) = \frac{p}{q} = n$$

**Exercise13:** Suppose that  $\lim_{z \rightarrow z_0} f(z) = w_0$  and  $\lim_{z \rightarrow z_0} F(z) = W_0$  exist  
Then show that (Try yourself)

- i.  $\lim_{z \rightarrow z_0} [f(z) + F(z)] = [w_0 + W_0]$
- ii.  $\lim_{z \rightarrow z_0} [f(z) - F(z)] = [w_0 - W_0]$
- iii.  $\lim_{z \rightarrow z_0} z^n = z_0^n$  ;  $n = 1, 2, 3, \dots$  By mathematical induction.
- iv.  $\lim_{z \rightarrow z_0} \frac{1}{z^n} = \frac{1}{z_0^n}$  ,  $z_0^n \neq 0$  ;  $n = 1, 2, 3, \dots$  By mathematical induction.
- v.  $\lim_{z \rightarrow z_0} P(z) = P(z_0)$  where  $P(z)$  is a Polynomial of degree 'n'
- vi.  $\lim_{z \rightarrow z_0} \text{Re}(z) = \text{Re}(z_0)$
- vii.  $\lim_{z \rightarrow z_0} \bar{z} = \bar{z}_0$
- viii.  $\lim_{z \rightarrow 0} \frac{\bar{z}^2}{z} = 0$
- ix.  $\lim_{z \rightarrow z_0} [az + b] = [az_0 + b]$
- x.  $\lim_{z \rightarrow i} \frac{iz^3 - 1}{z + i} = 0$
- xi.  $\lim_{z \rightarrow z_0} \frac{P(z)}{Q(z)} = \frac{P(z_0)}{Q(z_0)}$
- xii.  $\lim_{z \rightarrow z_0} [z^2 + c] = [z_0^2 + c]$
- xiii.  $\lim_{z \rightarrow 1 - i} [x + i(2x + y)] = 1 + i$
- xiv.  $\lim_{z \rightarrow 1 + i} (2 + i)z = 1 + 3i$
- xv.  $\lim_{z \rightarrow 1 + i} [z^2 - 5z + 10] = 5 - 3i$
- xvi.  $\lim_{z \rightarrow -2i} \frac{(2z+3)(z-1)}{z^2 - 2z + 4} = -\frac{1}{2} + \frac{11}{4}i$
- xvii.  $\lim_{z \rightarrow 2i} \frac{z^2 + 4}{z - 2i} = 4i$
- xviii.  $\lim_{z \rightarrow 2e^{i(\frac{\pi}{3})}} \frac{z^3 + 8}{z^4 + 4z^2 + 16} = \frac{3}{8} - \frac{\sqrt{3}}{8}i$
- xix.  $\lim_{z \rightarrow i} \frac{3z^4 - 2z^3 + 8z^2 - 2z + 5}{z - i} = 4 + 4i$  by using  $\epsilon, \delta$  form.
- xx. If  $\lim_{z \rightarrow z_0} f(z) = w_0$  exists then  $\lim_{z \rightarrow z_0} |f(z)| = |w_0|$  also exists.
- xxi.  $\lim_{z \rightarrow z_0} f(z) = w_0$  iff  $\lim_{\Delta z \rightarrow 0} f(z_0 + \Delta z) = w_0$  when  $\Delta z = z - z_0$
- xxii.  $\lim_{z \rightarrow z_0} f(z) \cdot g(z) = 0$  if  $\lim_{z \rightarrow z_0} f(z) = 0$  and if there exists a positive number  $M$  such that  $|g(z)| \leq M$  for all 'z' in some neighborhood of  $z_0$
- xxiii. Show that  $\lim_{z \rightarrow 0} f(z)$  does not exist for  $f(z) = \left(\frac{z}{\bar{z}}\right)^2$

### LIMITS INVOLVING THE POINT AT INFINITY

The complex plane together with the *point at infinity* is called the **extended complex plane**. We say that  $\lim_{z \rightarrow \infty} f(z) = l$  or  $f(z) \rightarrow l$  as  $z \rightarrow \infty$  if for each positive number  $\epsilon$  there exist positive numbers  $\delta$  such that  $|f(z) - l| < \epsilon$  Whenever  $|z| > M$   
Similarly we say that  $\lim_{z \rightarrow z_0} f(z) = \infty$  or  $f(z) \rightarrow \infty$  as  $z \rightarrow z_0$  if for each positive number  $\epsilon$  there exist positive numbers  $\delta$  such that

$$|f(z)| > \epsilon \quad \text{Whenever} \quad 0 < |z - z_0| < \delta$$

**Theorem:** Show that  $\lim_{z \rightarrow z_0} f(z) = \infty$  if  $\lim_{z \rightarrow z_0} \frac{1}{f(z)} = 0$

**Proof:** Suppose that  $\lim_{z \rightarrow z_0} \frac{1}{f(z)} = 0$  exists then for each positive number  $\epsilon$  there exists positive numbers  $\delta$  Such that

$$\left| \frac{1}{f(z)} - 0 \right| < \epsilon \text{ whenever } 0 < |z - z_0| < \delta$$

$$|f(z)| > \frac{1}{\epsilon} \text{ whenever } 0 < |z - z_0| < \delta \Rightarrow \lim_{z \rightarrow z_0} f(z) = \infty \text{ exists.}$$

**Example:** if  $\lim_{z \rightarrow -1} \frac{iz+3}{z+1} = \infty$  Since  $\lim_{z \rightarrow -1} \frac{z+1}{iz+3} = 0$

**Theorem:** Show that  $\lim_{z \rightarrow \infty} f(z) = w_0$  if  $\lim_{z \rightarrow 0} f\left(\frac{1}{z}\right) = w_0$

**Proof:** Suppose that  $\lim_{z \rightarrow 0} f\left(\frac{1}{z}\right) = w_0$  exists then for each positive number  $\epsilon$  there exists positive numbers  $\delta$  Such that

$$\left| f\left(\frac{1}{z}\right) - w_0 \right| < \epsilon \text{ whenever } 0 < |z - 0| < \delta$$

Replacing 'z' by '1/z'

$$|f(z) - w_0| < \epsilon \text{ whenever } |z| > \frac{1}{\delta} \Rightarrow \lim_{z \rightarrow \infty} f(z) = w_0 \text{ exists.}$$

**Example:** if  $\lim_{z \rightarrow \infty} \frac{2z+i}{z+1} = 2$  Since  $\lim_{z \rightarrow 0} \frac{\frac{2}{z}+i}{\frac{1}{z}+1} = \lim_{z \rightarrow 0} \frac{2+iz}{1+z} = 2$

**Theorem:** Show that  $\lim_{z \rightarrow \infty} f(z) = \infty$  if  $\lim_{z \rightarrow 0} \frac{1}{f\left(\frac{1}{z}\right)} = 0$

**Proof:** Suppose that  $\lim_{z \rightarrow 0} \frac{1}{f\left(\frac{1}{z}\right)} = 0$  exists then for each positive number  $\epsilon$  there exists positive numbers  $\delta$  Such that

$$\left| \frac{1}{f\left(\frac{1}{z}\right)} - 0 \right| < \epsilon \text{ whenever } 0 < |z - 0| < \delta$$

Replacing 'z' by '1/z'

$$|f(z)| > \frac{1}{\epsilon} \text{ whenever } |z| > \frac{1}{\delta} \Rightarrow \lim_{z \rightarrow \infty} f(z) = \infty \text{ exists.}$$

**Example:** if  $\lim_{z \rightarrow \infty} \frac{2z^3-1}{z^2+1} = \infty$  Since  $\lim_{z \rightarrow 0} \frac{1/z^2+1}{2/z^3-1} = \lim_{z \rightarrow 0} \frac{z+z^3}{2-z^3} = 2$

**Exercise 14: (visit @ Youtube “learning with Usman Hamid”)**

- i. Show that  $\lim_{z \rightarrow \infty} \frac{4z^2}{(z-1)^2} = 4$
- ii. Show that  $\lim_{z \rightarrow 1} \frac{1}{(z-1)^3} = \infty$
- iii. Show that  $\lim_{z \rightarrow \infty} \frac{z^2+1}{z-1} = \infty$
- iv. State why limits involving the points at infinity are unique.

**CONTINUITY:**

A complex valued function  $W = f(z)$  is said to be continuous at  $z = z_0$  in the domain  $D$  if  $\lim_{z \rightarrow z_0} f(z) = f(z_0)$  exists.

Above limit implies three conditions that must be met in order that  $f(z)$  be continuous at  $z = z_0$  if

- i.  $f(z_0)$  must exist. i.e.  $f(z)$  is defined at  $z = z_0$
- ii.  $\lim_{z \rightarrow z_0} f(z) = w_0$  must exist.
- iii. The value and limit agree at  $z = z_0$  i.e.  $\lim_{z \rightarrow z_0} f(z) = f(z_0)$

If these conditions not satisfy then function is said to be discontinuous.

 **$\epsilon, \delta$  FORM**

A complex valued function  $W = f(z)$  is said to be continuous at  $z = z_0$  if for each positive number  $\epsilon$ , there is a positive number  $\delta$  such that

$$|f(z) - f(z_0)| < \epsilon \quad \text{whenever} \quad |z - z_0| < \delta.$$

**Note** that this is simply the definition of limit and removal of the restriction that  $z \neq z_0$

**Remark:**

- A complex valued function  $W = f(z)$  is said to be continuous at in the domain  $D$  if it is continuous at each point of the domain
- For continuous function we may write  $\lim_{z \rightarrow z_0} f(z) = f(\lim_{z \rightarrow z_0} z)$
- If  $\lim_{z \rightarrow z_0} f(z) = w_0$  but  $\lim_{z \rightarrow z_0} f(z) \neq f(z_0)$  then discontinuity is known as **Removable discontinuity**.

**Theorem:** Prove that  $W = f(z)$  is continuous if and only if its real and Imaginary Parts are continuous.

**Proof:** Suppose that  $W = f(z)$  is continuous then  $\lim_{z \rightarrow z_0} f(z) = f(z_0) = w_0$  exist then for each positive number  $\epsilon$  there exists positive numbers  $\delta$  Such that

$$|(u + iv) - (u_0 + iv_0)| < \epsilon \quad \text{whenever} \quad |(x + iy) - (x_0 + iy_0)| < \delta$$

$$\text{But } |u - u_0| < |(u - u_0) + i(v - v_0)| \leq |u - u_0| + |v - v_0|$$

$$|u - u_0| = |(u + iv) - (u_0 + iv_0)| < \epsilon$$

$$\text{And } |v - v_0| < |(u - u_0) + i(v - v_0)| \leq |u - u_0| + |v - v_0|$$

$$|v - v_0| = |(u + iv) - (u_0 + iv_0)| < \epsilon \quad \text{Whenever } |z - z_0| < \delta$$

Hence  $\lim_{(x,y) \rightarrow (x_0,y_0)} u(x,y) = u_0$  and  $\lim_{(x,y) \rightarrow (x_0,y_0)} v(x,y) = v_0$  exists.

And real and Imaginary Parts are continuous.

**Conversely:** Suppose that real and Imaginary Parts of function are continuous and  $\lim_{(x,y) \rightarrow (x_0,y_0)} u(x,y) = u_0$  and  $\lim_{(x,y) \rightarrow (x_0,y_0)} v(x,y) = v_0$  exist then for each positive number  $\epsilon$  there exist positive numbers  $\delta_1$  and  $\delta_2$  Such that

$$|u - u_0| < \frac{\epsilon}{2} \quad \text{Whenever} \quad \sqrt{(x - x_0)^2 + (y - y_0)^2} < \delta_1$$

$$|v - v_0| < \frac{\epsilon}{2} \quad \text{Whenever} \quad \sqrt{(x - x_0)^2 + (y - y_0)^2} < \delta_2$$



Let  $\delta = \min(\delta_1, \delta_2)$  then consider

$$|(u + iv) - (u_0 + iv_0)| = |(u - u_0) + i(v - v_0)| \leq |u - u_0| + |v - v_0|$$

$$|(u + iv) - (u_0 + iv_0)| \leq |u - u_0| + |v - v_0| < \frac{\epsilon}{2} + \frac{\epsilon}{2} = \epsilon$$

$$|(u + iv) - (u_0 + iv_0)| < \epsilon \text{ whenever } |(x + iy) - (x_0 + iy_0)| < \delta$$

$$|f(z) - f(z_0)| < \epsilon \text{ whenever } |z - z_0| < \delta$$

Thus  $\lim_{z \rightarrow z_0} f(z) = f(z_0) = w_0$  exists thus  $W = f(z)$  is continuous.

**Question:** Show that  $f(z) = \bar{z}$  is continuous on  $\mathbb{C}$ .

**Solution:** let  $z_0 \in \mathbb{C}$  then  $z_0 = x_0 + iy_0$  and given  $f(z) = \bar{z}$  then

- i.  $f(z_0) = \bar{z}_0 = \overline{x_0 + iy_0} = x_0 - iy_0$ . i.e.  $f(z)$  is defined at  $z = z_0$
  - ii.  $\lim_{z \rightarrow z_0} f(z) = \lim_{z \rightarrow (x_0 + iy_0)} \bar{z} = \overline{x_0 + iy_0} = x_0 - iy_0$
  - iii. The value and limit agree at  $z = z_0$  i.e.  $\lim_{z \rightarrow z_0} f(z) = f(z_0)$
- Hence  $f(z) = \bar{z}$  is continuous on  $\mathbb{C}$ .

**Exercise 15:** Show that given functions are continuous at  $z = z_0$  or not?

- i.  $f(z) = |z|^2$  at  $z = z_0$
- ii.  $f(z) = z^2$  at  $z = z_0$
- iii.  $f(z) = z^2 - iz + 2$  at  $z_0 = 1 - i$
- iv.  $f(z) = z^2$  in the region  $|z| \leq 1$
- v.  $f(z) = \begin{cases} \frac{z^2+4}{z+2i} & z \neq -2i \\ -5 & z = -2i \end{cases}$
- vi.  $f(z) = \begin{cases} z^2 & z \neq i \\ 0 & z = i \end{cases}$
- vii.  $f(z) = e^{1/z^2}$  at  $z = 0$
- viii.  $f(z) = \frac{3z^4 - 2z^3 + 8z^2 - 2z + 5}{z-i}$  at  $z = i$  is removable discontinuous.

### UNIFORM CONTINUITY:

A complex valued function  $W = f(z)$  is said to be uniformly continuous in a Domain  $D$  if for each positive number  $\epsilon$ , there is a positive number  $\delta$  such that

$$|f(z_1) - f(z_2)| < \epsilon \text{ whenever } |z_1 - z_2| < \delta.$$

#### Remark:

- in continuity of function  $\delta$  depends upon  $\epsilon$  as well as on a particular point  $z_0$
- In Uniform continuity of function  $\delta$  depends upon  $\epsilon$  but not on a Particular point  $z_0$
- Uniform continuity is a property of a function on a set. And is a **Global property**. But continuity can be defined at a single point and Is a **local property**.
- Uniform continuity of a function at a point have no meaning.
- Continuous function on a closed and bounded region will be Uniformly continuous.

**Question:** Let  $R$  consists of set of all points 'z' such that  $0 < |z| \leq 1$  and  $f(z) = z^2$ . Verify that function is uniformly continuous.

**Solution:** Given that  $f(z) = z^2$ ,  $0 < |z| \leq 1$  and  $z_1, z_2 \in R$  then

$$0 < |z_1| \leq 1, \quad 0 < |z_2| \leq 1$$

$$\text{Consider } |f(z_1) - f(z_2)| = |z_1^2 - z_2^2| = |(z_1 - z_2)(z_1 + z_2)| = |z_1 - z_2||z_1 + z_2|$$

Since  $0 < |z_1| \leq 1, 0 < |z_2| \leq 1$  therefore

$$|f(z_1) - f(z_2)| \leq 2|z_1 - z_2| \quad \because |z_1 + z_2| = |1 + 1| = 2$$

$$|f(z_1) - f(z_2)| \leq 2\delta \quad \text{Whenever } |z_1 - z_2| < \delta = \frac{\epsilon}{2}$$

$$|f(z_1) - f(z_2)| < 2 \cdot \frac{\epsilon}{2} \quad \text{Whenever } |z_1 - z_2| < \delta = \frac{\epsilon}{2}$$

$$|f(z_1) - f(z_2)| < \epsilon \quad \text{Whenever } |z_1 - z_2| < \delta$$

$f(z) = z^2$  is uniformly continuous on  $R$

**Note** that in expression  $|f(z_1) - f(z_2)| \leq 2|z_1 - z_2|$  equality will hold when  $|z_1| = 1, |z_2| = 1$ .

**Exercise 16:** Show that given functions are uniformly continuous at  $z = z_0$  or not?

- i.  $f(z) = \frac{1}{z}$  in the region  $|z| < 1$  (not continuous)
- ii.  $f(z) = z^2 - 1$  in the region  $|z| \leq 4$

**Theorem:** A composition of continuous functions is itself continuous.

**Proof:** Suppose that  $g[f(z)]$  be a continuous function defined for all  $f(z)$  in the Neighborhood of  $f(z_0)$  then by definition;

$$|g[f(z)] - g[f(z_0)]| < \epsilon \quad \text{whenever } |f(z) - f(z_0)| < \gamma \dots\dots(i)$$

Similarly suppose that  $f(z)$  be a continuous function defined for all  $z$  in the Neighborhood of  $z_0$  then by definition;

$$|f(z) - f(z_0)| < \gamma \quad \text{whenever } |z - z_0| < \delta \dots\dots(ii)$$

Combining (i) and (ii)

$$|g[f(z)] - g[f(z_0)]| < \epsilon \quad \text{whenever } |z - z_0| < \delta$$

Hence composition of continuous functions is itself continuous.

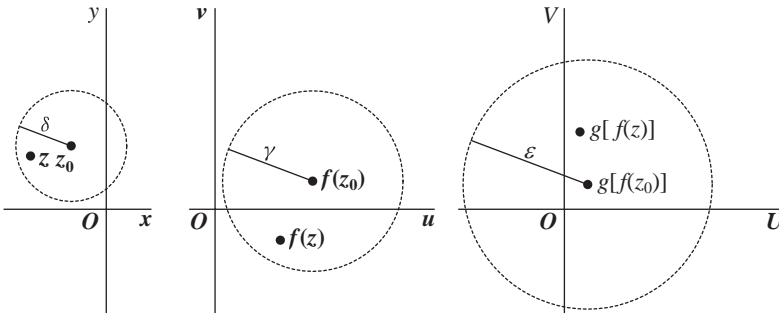

**Theorem:** If a function  $f(z)$  is continuous and nonzero at a point  $z_0$ ,  
Then  $f(z) \neq 0$  throughout some neighborhood of that point.

**Proof:** Suppose that function  $f(z)$  is continuous and nonzero at a point  $z_0$ ,  
and  $f(z) = 0$  throughout some neighborhood of that point. Then by definition  
of continuity

$$|f(z) - f(z_0)| < \epsilon \quad \text{whenever} \quad |z - z_0| < \delta$$

take  $\epsilon = \frac{|f(z_0)|}{2}$  and  $f(z) = 0$  then

$$|f(z_0)| < \frac{|f(z_0)|}{2} \quad \text{whenever} \quad |z - z_0| < \delta \quad \text{Which is contradiction.}$$

Hence If a function  $f(z)$  is continuous and non-zero at a point  $z_0$ ,  
Then  $f(z) \neq 0$  throughout some neighborhood of that point.

**Theorem:** If a function  $f(z)$  is continuous throughout a region  $R$  that is  
Both closed and bounded. Then there exist a non-negative real number  $M$   
such that  $|f(z)| \leq M$  for all point 'z' in  $R$ .

**Proof:** Suppose that function  $f(z) = u(x, y) + iv(x, y)$  is continuous. Then  $|f(z)|$   
Will be continuous throughout  $R$  and thus reaches a maximum value (say)  $M$   
somewhere in  $R$ . then  $|f(z)| \leq M$  for all point 'z' in  $R$ . And we will say that  $f$  is  
bounded on  $R$ .

## DERIVATIVES:

Given  $W = f(z)$  be a single valued function defined in a domain  $D$  and let  
 $z_0$  be any fixed point in  $D$ . Then  $W = f(z)$  is said to have a derivative at  
 $z_0$  if the following limits exists.

$$\frac{df}{dz} = \frac{dW}{dz} = f'(z_0) = \lim_{z \rightarrow z_0} \frac{f(z) - f(z_0)}{z - z_0}$$

$$\text{Or } f'(z_0) = \lim_{\Delta z \rightarrow 0} \frac{f(z_0 + \Delta z) - f(z_0)}{\Delta z} \quad \text{where } \Delta z = z - z_0$$

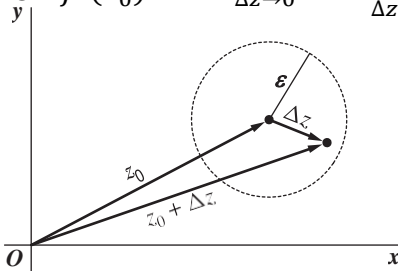

## $\epsilon, \delta$ FORM

A complex valued function  $W = f(z)$  is said to be a derivative at  $z = z_0$  if  
for each positive number  $\epsilon$ , there is a positive number  $\delta$  such that

$$\left| \frac{f(z) - f(z_0)}{z - z_0} - f'(z_0) \right| < \epsilon \quad \text{whenever} \quad 0 < |z - z_0| < \delta.$$

**Remark:**

- i. Instantaneous rate of change of one variable with respect to other Variable is called **derivative** and method to find derivative is called Differentiation or Differentiability.
- ii. **Graphically**, the derivative of a function corresponds to the slope of its tangent line at one specific point.

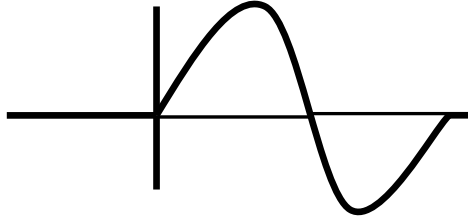

- iii. Since  $W = f(z)$  defined through a neighborhood of 'z' therefore the Number  $f(z_0 + \Delta z)$  is always defined for  $|\Delta z|$  sufficiently small.

**Theorem:** Prove that  $W = f(z)$  is differentiable then it will be continuous.

**Proof:** Suppose that  $W = f(z)$  is differentiable at a point  $z_0$  then

$$f'(z_0) = \lim_{z \rightarrow z_0} \frac{f(z) - f(z_0)}{z - z_0}$$

Now we have to prove that  $f(z)$  is continuous.

$$\text{Consider } f(z) - f(z_0) = \frac{f(z) - f(z_0)}{z - z_0} \times z - z_0$$

$$\text{Then } \lim_{z \rightarrow z_0} [f(z) - f(z_0)] = \lim_{z \rightarrow z_0} \frac{f(z) - f(z_0)}{z - z_0} \times \lim_{z \rightarrow z_0} z - z_0$$

$$[\lim_{z \rightarrow z_0} f(z)] - f(z_0) = f'(z_0) \times 0 \Rightarrow [\lim_{z \rightarrow z_0} f(z)] - f(z_0) = 0$$

$$\Rightarrow \lim_{z \rightarrow z_0} f(z) = f(z_0) \Rightarrow W = f(z) \text{ is continuous}$$

**Remark:** Convers of above theorem is not true.

**Question:** Show that  $f(z) = \bar{z}$  is continuous but not differentiable.

**Solution:** let  $z_0 \in \mathbb{C}$  then  $z_0 = x_0 + iy_0$  and given  $f(z) = \bar{z}$  then

- i.  $f(z_0) = \bar{z}_0 = \overline{x_0 + iy_0} = x_0 - iy_0$ . i.e.  $f(z)$  is defined at  $z = z_0$
- ii.  $\lim_{z \rightarrow z_0} f(z) = \lim_{z \rightarrow (x_0 + iy_0)} \bar{z} = \overline{x_0 + iy_0} = x_0 - iy_0$
- iii. The value and limit agree at  $z = z_0$  i.e.  $\lim_{z \rightarrow z_0} f(z) = f(z_0)$

Hence  $f(z) = \bar{z}$  is continuous on  $\mathbb{C}$ .

Now for **Differentiability**.

$$f'(z_0) = \lim_{z \rightarrow z_0} \frac{f(z) - f(z_0)}{z - z_0} = \lim_{z \rightarrow z_0} \frac{\bar{z} - \bar{z}_0}{z - z_0} = \lim_{z \rightarrow z_0} \frac{\overline{z - z_0}}{z - z_0}$$

Let  $z - z_0 = \Delta z$  then if  $z \rightarrow z_0$  then  $\Delta z \rightarrow 0$

$$\Rightarrow f'(z_0) = \lim_{\Delta z \rightarrow 0} \frac{\overline{\Delta z}}{\Delta z} = \pm 1 \text{ i.e. when '}\Delta z\text{' is real then limit is '1' and}$$

when ' $\Delta z$ ' is imaginary then limit is ' $-1$ ' therefore limit does not exist and function is not differentiable.

**REMARK:** At  $z = 0$  the function is continuous as well as differentiable.

**Question:** Show that  $f(z) = |z|^2 = z\bar{z}$  is continuous but not differentiable.

**Solution:** let  $z_0 \in \mathbb{C}$  and given  $f(z) = |z|^2$  then

- $f(z_0) = |z_0|^2$ . i.e.  $f(z)$  is defined at  $z = z_0$
- $\lim_{z \rightarrow z_0} f(z) = \lim_{z \rightarrow z_0} |z|^2 = |z_0|^2$
- The value and limit agree at  $z = z_0$  i.e.  $\lim_{z \rightarrow z_0} f(z) = f(z_0)$

Hence  $f(z) = |z|^2$  is continuous on  $\mathbb{C}$ .

Now for **Differentiability**.

$$f'(z_0) = \lim_{z \rightarrow z_0} \frac{f(z) - f(z_0)}{z - z_0} = \lim_{z \rightarrow z_0} \frac{|z|^2 - |z_0|^2}{z - z_0} = \lim_{z \rightarrow z_0} \frac{z\bar{z} - z_0\bar{z}_0}{z - z_0}$$

$$f'(z_0) = \lim_{z \rightarrow z_0} \frac{z\bar{z} - \bar{z}z_0 + \bar{z}z_0 - z_0\bar{z}_0}{z - z_0} = \lim_{z \rightarrow z_0} \frac{\bar{z}(z - z_0) + z_0(\bar{z} - \bar{z}_0)}{z - z_0} = \lim_{z \rightarrow z_0} \left[ \bar{z} + \frac{z_0(\bar{z} - \bar{z}_0)}{z - z_0} \right]$$

Let  $z - z_0 = \Delta z$  then if  $z \rightarrow z_0$  then  $\Delta z \rightarrow 0$

$$\Rightarrow f'(z_0) = \lim_{\Delta z \rightarrow 0} \left[ \bar{z} + \frac{z_0(\Delta z)}{\Delta z} \right]$$

when ' $\Delta z$ ' is real then limit is ' $\bar{z} + z_0$ ' and

when ' $\Delta z$ ' is imaginary then limit is ' $\bar{z} - z_0$ '

Therefore limit does not exist and function is not differentiable.

**REMARK:** At  $z = 0$  the function is continuous as well as differentiable.

**Question:** Show that  $f'(z) = -\frac{1}{z^2}$  when  $f(z) = \frac{1}{z}$  at each  $z \neq 0$

**Solution:** by using the definition

$$f'(z) = \lim_{\Delta z \rightarrow 0} \frac{f(z + \Delta z) - f(z)}{\Delta z} = \lim_{\Delta z \rightarrow 0} \left[ \frac{1}{(z + \Delta z)} - \frac{1}{z} \right] \cdot \frac{1}{\Delta z} = \lim_{\Delta z \rightarrow 0} \left[ \frac{-1}{(z + \Delta z)z} \right]$$

$$\Rightarrow f'(z) = -\frac{1}{z^2} \text{ at each } z \neq 0$$

**Exercise 17: (visit @ Youtube "learning with Usman Hamid")**

i. Show that  $f'(z) = 2z$  when  $f(z) = z^2$  at each  $z \neq 0$

ii. Find  $f'(z)$  when

a)  $f(z) = \left( \frac{1}{3}z^3 - \frac{1}{3z^3} \right)^4$

b)  $f(z) = \frac{1}{(z^4 + 2)^2}$

c)  $f(z) = 3z^2 - 2z + 4$

d)  $f(z) = (2z^2 + i)^5$

e)  $f(z) = \frac{z+1}{2z+1} ; z \neq -\frac{1}{2}$

f)  $f(z) = \frac{(1+z^2)^4}{z^2} ; z \neq 0$

iii. Suppose that  $f(z_0) = g(z_0) = 0$  and  $f'(z_0)$  and  $g'(z_0)$  exist, where

$$g'(z_0) \neq 0 \text{ then show that } \lim_{z \rightarrow z_0} \frac{f(z)}{g(z)} = \frac{f'(z_0)}{g'(z_0)}$$

iv. Show that  $f'(0)$  does not exist when  $f(z) = \begin{cases} \bar{z}^2 & z \neq 0 \\ z & z = 0 \end{cases}$

v. Show that  $f'(z)$  does not exist at any point ' $z$ ' when

a)  $f(z) = \operatorname{Re} z$

c)  $f(z) = |z|$

b)  $f(z) = \operatorname{Im} z$

d)  $f(z) = \arg(z)$

# CHAPTER 2

---

## ANALYTIC FUNCTIONS

### ANALYTIC / REGULAR / HOLOMORPHIC FUNCTION

A complex valued function  $W = f(z)$  is said to be Analytic in domain D if

- i.  $W = f(z)$  is single valued.
- ii.  $W = f(z)$  is differentiable in domain D.

### CAUCHY RIEMANN EQUATIONS

Let  $f(z) = u + iv$  be a complex valued function, whose first order partial derivative exists, then following pair of equations is called CR equation;

$$u_x = v_y \quad \text{and} \quad u_y = -v_x$$

We may also write  $\frac{\partial u}{\partial x} = \frac{\partial v}{\partial y}$  and  $\frac{\partial u}{\partial y} = -\frac{\partial v}{\partial x}$

### CAUCHY-RIEMANN EQUATIONS IN RECTANGULAR COORDINATES (necessary condition)

*Suppose that  $f(z) = u(x, y) + iv(x, y)$  and that  $f'(z)$  exists at a point  $z_0$*

*Then the first-order partial derivatives of  $u$  and  $v$  must exist at  $(x_0, y_0)$ ,*

*Then they must satisfy the Cauchy-Riemann equations i.e.  $u_x = v_y$  and  $u_y = -v_x$*

**Proof:** Given that  $f'(z)$  exists at a point  $z_0$   $f'(z_0) = \lim_{\Delta z \rightarrow 0} \frac{f(z_0 + \Delta z) - f(z_0)}{\Delta z}$

We have to prove  $u_x = v_y$  and  $u_y = -v_x$

$$\begin{aligned} \text{Consider } f'(z_0) &= \lim_{\Delta z \rightarrow 0} \frac{f(z_0 + \Delta z) - f(z_0)}{\Delta z} \\ \Rightarrow f'(z_0) &= \lim_{\Delta z \rightarrow 0} \frac{[u(x_0 + \Delta x, y_0 + \Delta y) + iv(x_0 + \Delta x, y_0 + \Delta y)] - [u(x_0, y_0) + iv(x_0, y_0)]}{\Delta x + i\Delta y} \end{aligned}$$

**Along horizontal axis:** Take  $\Delta x \rightarrow 0$  and  $\Delta y = 0$

$$\begin{aligned} \Rightarrow f'(z_0) &= \lim_{\Delta x \rightarrow 0} \frac{[u(x_0 + \Delta x, y_0) + iv(x_0 + \Delta x, y_0)] - [u(x_0, y_0) + iv(x_0, y_0)]}{\Delta x} \\ \Rightarrow f'(z_0) &= \lim_{\Delta x \rightarrow 0} \frac{[u(x_0 + \Delta x, y_0) - u(x_0, y_0)] + i[v(x_0 + \Delta x, y_0) - v(x_0, y_0)]}{\Delta x} \\ \Rightarrow f'(z_0) &= \lim_{\Delta x \rightarrow 0} \frac{[u(x_0 + \Delta x, y_0) - u(x_0, y_0)]}{\Delta x} + i \lim_{\Delta x \rightarrow 0} \frac{[v(x_0 + \Delta x, y_0) - v(x_0, y_0)]}{\Delta x} \\ \Rightarrow f'(z_0) &= u_x(x_0, y_0) + iv_x(x_0, y_0) \dots \dots \dots (i) \end{aligned}$$

**Along vertical axis:** Take  $\Delta y \rightarrow 0$  and  $\Delta x = 0$

$$\Rightarrow f'(z_0) = \lim_{\Delta y \rightarrow 0} \frac{[u(x_0, y_0 + \Delta y) + iv(x_0, y_0 + \Delta y)] - [u(x_0, y_0) + iv(x_0, y_0)]}{i\Delta y}$$

$$\Rightarrow f'(z_0) = \lim_{\Delta y \rightarrow 0} \frac{[u(x_0, y_0 + \Delta y) - u(x_0, y_0)] + i[v(x_0, y_0 + \Delta y) - v(x_0, y_0)]}{i\Delta y}$$

$$\Rightarrow f'(z_0) = \lim_{\Delta y \rightarrow 0} \frac{[u(x_0, y_0 + \Delta y) - u(x_0, y_0)]}{i\Delta y} + i \lim_{\Delta y \rightarrow 0} \frac{[v(x_0, y_0 + \Delta y) - v(x_0, y_0)]}{i\Delta y}$$

$$\Rightarrow f'(z_0) = -i \lim_{\Delta y \rightarrow 0} \frac{[u(x_0, y_0 + \Delta y) - u(x_0, y_0)]}{\Delta y} + \lim_{\Delta y \rightarrow 0} \frac{[v(x_0, y_0 + \Delta y) - v(x_0, y_0)]}{\Delta y}$$

$$\Rightarrow f'(z_0) = -iu_y(x_0, y_0) + v_y(x_0, y_0) = v_y - iu_y \quad \dots \dots \dots (ii)$$

Comparing real and imaginary parts of (i) and (ii) we get

$$u_x = v_y \quad \text{and} \quad v_x = -u_y \quad \text{which are CR equations.}$$

We may also write  $u_x = v_y$  and  $u_y = -v_x$

### Theorem (sufficient condition)

Suppose that  $f(z) = u(x, y) + iv(x, y)$  is defined throughout some neighborhood Of a point  $z_0$  and the first-order partial derivatives of  $u$  and  $v$  must exist at  $(x_0, y_0)$ , Also Cauchy–Riemann equations  $u_x = v_y$  and  $u_y = -v_x$  hold

Then  $f'(z)$  exists at a point  $z_0$

#### Proof:

Suppose that CR equations holds i.e.  $u_x = v_y$  and  $u_y = -v_x$  and continuous

Consider

$$f(z_0 + \Delta z) - f(z_0) =$$

$$[u(x_0 + \Delta x, y_0 + \Delta y) + iv(x_0 + \Delta x, y_0 + \Delta y)] - [u(x_0, y_0) + iv(x_0, y_0)]$$

Adding and subtracting  $u(x_0 + \Delta x, y_0)$  and  $v(x_0, y_0 + \Delta y)$

$$f(z_0 + \Delta z) - f(z_0) =$$

$$[u(x_0 + \Delta x, y_0 + \Delta y) - u(x_0 + \Delta x, y_0) + u(x_0 + \Delta x, y_0) - u(x_0, y_0)]$$

$$+ i[v(x_0 + \Delta x, y_0 + \Delta y) - v(x_0, y_0 + \Delta y) + v(x_0, y_0 + \Delta y) - v(x_0, y_0)]$$

Since

$$u(x_0 + \Delta x, y_0 + \Delta y) - u(x_0 + \Delta x, y_0) = \Delta y u_y + \epsilon_1 \Delta y$$

$$u(x_0 + \Delta x, y_0) - u(x_0, y_0) = \Delta x u_x + \epsilon_2 \Delta x$$

$$v(x_0 + \Delta x, y_0 + \Delta y) - v(x_0, y_0 + \Delta y) = \Delta x v_x + \epsilon_3 \Delta x$$

$$v(x_0, y_0 + \Delta y) - v(x_0, y_0) = \Delta y v_y + \epsilon_4 \Delta y$$

Then  $f(z_0 + \Delta z) - f(z_0) =$

$$[\Delta y u_y + \epsilon_1 \Delta y + \Delta x u_x + \epsilon_2 \Delta x] + i[\Delta x v_x + \epsilon_3 \Delta x + \Delta y v_y + \epsilon_4 \Delta y]$$

using CR equations i.e.  $u_x = v_y$  and  $u_y = -v_x$

Then  $f(z_0 + \Delta z) - f(z_0) =$

$$[-\Delta y v_x + \epsilon_1 \Delta y + \Delta x u_x + \epsilon_2 \Delta x] + i[\Delta x v_x + \epsilon_3 \Delta x + \Delta y u_x + \epsilon_4 \Delta y]$$

$$= [u_x(\Delta x + i\Delta y) + iv_x(\Delta x + i\Delta y) + \Delta x(\epsilon_2 + i\epsilon_3) + \Delta y(\epsilon_1 + i\epsilon_4)]$$

$$= [u_x(\Delta x + i\Delta y) + iv_x(\Delta x + i\Delta y) + \Delta x\delta_1 + \Delta y\delta_2]$$

Dividing by  $\Delta z = \Delta x + i\Delta y$

$$\frac{f(z_0+\Delta z)-f(z_0)}{\Delta z} = \frac{[u_x(\Delta x+i\Delta y)+iv_x(\Delta x+i\Delta y)+\Delta x\delta_1+\Delta y\delta_2]}{\Delta x+i\Delta y}$$

$$\frac{f(z_0+\Delta z)-f(z_0)}{\Delta z} = \frac{[u_x+iv_x](\Delta x+i\Delta y)+\Delta x\delta_1+\Delta y\delta_2}{\Delta x+i\Delta y}$$

$$\frac{f(z_0+\Delta z)-f(z_0)}{\Delta z} = (u_x + iv_x) + \frac{\Delta x\delta_1+\Delta y\delta_2}{\Delta x+i\Delta y}$$

$$\frac{f(z_0+\Delta z)-f(z_0)}{\Delta z} - (u_x + iv_x) = \frac{\Delta x\delta_1+\Delta y\delta_2}{\Delta x+i\Delta y}$$

$$\left| \frac{f(z_0+\Delta z)-f(z_0)}{\Delta z} - (u_x + iv_x) \right| = \left| \frac{\Delta x\delta_1+\Delta y\delta_2}{\Delta x+i\Delta y} \right| \leq \delta_1 \frac{|\Delta x|}{|\Delta x+i\Delta y|} + \delta_2 \frac{|\Delta y|}{|\Delta x+i\Delta y|}$$

$$\left| \frac{f(z_0+\Delta z)-f(z_0)}{\Delta z} - (u_x + iv_x) \right| < \delta_1 + \delta_2 < \epsilon \quad \therefore \frac{|\Delta x|}{|\Delta x+i\Delta y|} < 1 \text{ also } \frac{|\Delta y|}{|\Delta x+i\Delta y|} < 1$$

$$\Rightarrow f'(z_0) = u_x + iv_x \text{ or } \Rightarrow f'(z_0) = u_x - iv_y \text{ or } \Rightarrow f'(z_0) = v_y - iu_x$$

This is the definition of differentiability.

**Remark:**

- i. If  $W = f(z)$  is a non – constant real valued function (say)  $f(z) = |z|^2$   
Then CR equations do not hold.
- ii. If  $W = f(z)$  is a constant real valued function then CR equations hold.
- iii. If  $W = f(\bar{z})$  then CR equations do not hold.
- iv. If a function is analytic, CR equations necessarily hold, but if CR equations are satisfied for a function then the function may or may not be analytic.
- v. If a function involves  $\bar{z}$  then without verifying CR equations we can Say the function is non – analytic.
- vi. We may use  $u_x(0,0) = \lim_{x \rightarrow 0} \frac{u(x,0)-u(0,0)}{x}$  at origin  
Instead of  $u_x(0,0) = \lim_{\Delta x \rightarrow 0} \frac{[u(x+\Delta x,0)-u(0,0)]}{\Delta x}$  and vice versa.

**Example:** Since the function  $f(z) = z^2 = x^2 - y^2 + i2xy$

is differentiable everywhere and that  $f'(z) = 2z$ . Verify that the CR equations are satisfied everywhere.

**Solution:** write  $u(x, y) = x^2 - y^2$  and  $v(x, y) = 2xy$ .

Thus  $u_x = 2x = v_y$ ,  $u_y = -2y = -v_x$ .

Moreover,  $f'(z) = 2x + i2y = 2(x + iy) = 2z$ . i.e.  $f'(z)$  exists.



**Example:** Prove that for the function  $f(z) = \begin{cases} \frac{x^3(1+i)-y^3(1-i)}{x^2+y^2} & z \neq 0 \\ 0 & z = 0 \end{cases}$

CR equations are satisfied at  $z = 0$  but function is not differentiable i.e. not analytic at  $z = 0$

**Solution:** Given that  $f(z) = \frac{x^3(1+i)-y^3(1-i)}{x^2+y^2} = \frac{(x^3-y^3)+i(x^3+y^3)}{x^2+y^2}$

Then  $u(x, y) = \frac{x^3-y^3}{x^2+y^2}$  also  $v(x, y) = \frac{x^3+y^3}{x^2+y^2}$

Then at origin

$$\Rightarrow u_x(0,0) = \lim_{x \rightarrow 0} \frac{u(x,0)-u(0+0)}{x} = \lim_{x \rightarrow 0} \frac{x^3}{x^2 \cdot x} = 1$$

$$\Rightarrow u_y(0,0) = \lim_{y \rightarrow 0} \frac{u(0,y)-u(0+0)}{y} = \lim_{y \rightarrow 0} \frac{-y^3}{y^2 \cdot y} = -1$$

$$\Rightarrow v_x(0,0) = \lim_{x \rightarrow 0} \frac{v(x,0)-v(0+0)}{x} = \lim_{x \rightarrow 0} \frac{x^3}{x^2 \cdot x} = 1$$

$$\Rightarrow v_y(0,0) = \lim_{y \rightarrow 0} \frac{v(0,y)-v(0+0)}{y} = \lim_{y \rightarrow 0} \frac{y^3}{y^2 \cdot y} = 1$$

Thus  $u_x = v_y$  and  $u_y = -v_x$  i.e. CR equations hold.

**Now for Differentiability at origin i.e.  $z=0$ :**

$$f'(0) = \lim_{z \rightarrow 0} \frac{f(z)-f(0)}{z-0} = \lim_{z \rightarrow 0} \frac{\frac{(x^3-y^3)+i(x^3+y^3)}{x^2+y^2} - 0}{x+iy} = \frac{(x^3-y^3)+i(x^3+y^3)}{(x+iy)(x^2+y^2)}$$

**Case I: Take  $y = x$**

$$f'(0) = \lim_{x \rightarrow 0} \frac{2ix^3}{2x^3(1+i)} = \frac{i}{(1+i)}$$

**Case II: Take  $y=0$  and  $x \rightarrow 0$**

$$f'(0) = \lim_{x \rightarrow 0} \frac{x^3(1+i)}{x^3} = (1+i)$$

$\Rightarrow f'(0)$  does not exist. Hence CR equations are true function is not analytic.

**Example:** Prove that for the function  $f(z) = e^z = e^x(\text{Cos}y + i\text{Sin}y)$

CR equations are satisfied at  $z = 0$  and also function is analytic at origin.

**Solution:** Given that  $f(z) = e^x(\text{Cos}y + i\text{Sin}y) = e^x\text{Cos}y + ie^x\text{Sin}y$

Then  $u(x, y) = e^x\text{Cos}y$  also  $v(x, y) = e^x\text{Sin}y$

Then at origin

$$\Rightarrow u_x(0,0) = \lim_{x \rightarrow 0} \frac{u(x,0)-u(0+0)}{x} = \lim_{x \rightarrow 0} \frac{e^x-1}{x} = 1$$

$$\Rightarrow u_y(0,0) = \lim_{y \rightarrow 0} \frac{u(0,y)-u(0+0)}{y} = \lim_{y \rightarrow 0} \frac{\text{Cos}y-1}{y} = \lim_{y \rightarrow 0} \frac{-\text{Sin}y}{1} = 0$$

$$\Rightarrow v_x(0,0) = \lim_{x \rightarrow 0} \frac{v(x,0)-v(0+0)}{x} = \lim_{x \rightarrow 0} \frac{0-0}{x} = 0$$

$$\Rightarrow v_y(0,0) = \lim_{y \rightarrow 0} \frac{v(0,y)-v(0+0)}{y} = \lim_{y \rightarrow 0} \frac{\text{Sin}y}{y} = \lim_{y \rightarrow 0} \frac{\text{Cos}y}{1} = 1$$

Thus  $u_x = v_y$  and  $u_y = -v_x$  i.e. CR equations hold.

**Now for Differentiability at origin i.e.  $z=0$ :**

$$f'(z) = u_x + iv_x = e^x\text{Cos}y + ie^x\text{Sin}y = e^x(\text{Cos}y + i\text{Sin}y)$$

$\Rightarrow f'(0) = |e^x(\text{Cos}y + i\text{Sin}y)|_0 = 1$  CR equations are satisfied at  $z = 0$  and also function is analytic at origin.

**Exercise 18: (visit @ Youtube “learning with Usman Hamid”)**

1. Prove that for the function  $f(z) = |z|^2$  if CR equations are Satisfied but  $f'(z)$  does not exists at any non – zero point.
2. Prove that for the function  $f(z) = \begin{cases} \bar{z}^2 & z \neq 0 \\ 0 & z = 0 \end{cases}$  CR equations are satisfied but  $f'(0)$  does not exists at any non – zero point.
3. Prove that for the function  $f(z) = \sqrt{|xy|}$  is not analytic at the origin Although the CR equations are satisfied at origin.
4. Examine the nature of the function  $f(z) = \begin{cases} \frac{x^2y^5(x+iy)}{x^4+y^{10}} & z \neq 0 \\ 0 & z = 0 \end{cases}$  in a region including the origin.
5. Prove that for the function  $f(z) = \begin{cases} \frac{xy^2(x+iy)}{x^2+y^4} & z \neq 0 \\ 0 & z = 0 \end{cases}$  is not Analytic at the origin Although the CR equations are satisfied at origin.
6. Prove that for the function  $f(z) = \begin{cases} e^{-z^{-4}} & z \neq 0 \\ 0 & z = 0 \end{cases}$  is not analytic at the origin Although the CR equations are satisfied at origin.
7. For the function  $f(z) = x^3 + i(1 - y)^3$  Prove that  $f'(z)$  Exists only when  $z = i$
8. For the following functions show that  $f'(z)$  does not exist as CR equations are not satisfied.
  - i.  $f(z) = \bar{z}$
  - ii.  $f(z) = z - \bar{z}$
  - iii.  $f(z) = 2x + ixy^2$
  - iv.  $f(z) = e^x e^{-iy}$
9. Show that  $f'(z)$  and its derivative  $f''(z)$  exist every-where and find  $f''(z)$  when
  - (a)  $f(z) = iz + 2$
  - (b)  $f(z) = e^{-x} e^{-iy}$
  - (c)  $f(z) = z^3$
  - (d)  $f(z) = \cos x \cosh y - i \sin x \sinh y$ .
10. Determine where  $f'(z)$  exists and find its value when;
  - (a)  $f(z) = 1/z$
  - (b)  $f(z) = x^2 + iy^2$
  - (c)  $f(z) = z \operatorname{Im} z$ .
11. Show that the function  $f(z) = x + 4iy$  is nowhere differentiable.
12. Show that the function  $f(z) = z^2 + z$  is analytic.
13. Show that the function  $f(z) = 2x^2 + y + i(y^2 - x)$  is not analytic.

**Example:** Prove that the essential characteristic for a function to be analytic

Is that it is a function of 'z' alone, it does not involve  $\bar{z}$  or  $\frac{\partial f}{\partial \bar{z}} = 0 = f_{\bar{z}}$

**Solution:** Given that  $f(z)$  is analytic.  $u_x = v_y$  and  $u_y = -v_x$

We know that  $z = x + iy$  and  $\bar{z} = x - iy$  then  $x = \frac{z + \bar{z}}{2}$  also  $y = \frac{z - \bar{z}}{2i}$

$$x_{\bar{z}} = \frac{1}{2} \text{ also } y_{\bar{z}} = -\frac{1}{2i}$$

$$\text{Consider } \frac{\partial f}{\partial \bar{z}} = \frac{\partial f}{\partial x} \cdot \frac{\partial x}{\partial \bar{z}} + \frac{\partial f}{\partial y} \cdot \frac{\partial y}{\partial \bar{z}} \Rightarrow f_{\bar{z}} = f_x \cdot x_{\bar{z}} + f_y \cdot y_{\bar{z}} = \frac{1}{2}f_x - \frac{1}{2i}f_y \dots\dots\dots(i)$$

Now  $f_x = u_x + iv_x$  also  $f_y = u_y + iv_y$

$$(i) \Rightarrow f_{\bar{z}} = \frac{1}{2}f_x - \frac{1}{2i}f_y = \frac{1}{2}(u_x + iv_x) - \frac{1}{2i}(u_y + iv_y)$$

After using CR equations. i.e.  $u_x = v_y$  and  $u_y = -v_x$

$$f_{\bar{z}} = \frac{1}{2}u_x + \frac{i}{2}v_x - \frac{i}{2}v_x - \frac{1}{2}u_x = 0 \Rightarrow \frac{\partial f}{\partial \bar{z}} = 0 = f_{\bar{z}}$$

**Remark:** If a function involve  $\bar{z}$  then without verifying CR equations we can Say the function is non - analytic.

For example:  $f(z) = \text{Sin}(16x + 24iy) = \text{Sin}(20z - 4\bar{z})$  involves  $\bar{z}$  therefore It is non - analytic.

**Exercise 19: (visit @ Youtube “learning with Usman Hamid”)**

1) Without verifying CR equations , Prove that following function are non - analytic.

- i.  $f(z) = \text{Sin}(37x + 35iy)$
- ii.  $f(z) = \text{Cos}(7x + 5iy)$
- iii.  $f(z) = \text{Sin}(x - iy)$
- iv.  $W = 2ix$
- v.  $W = -4y$
- vi.  $W = |z|$

2) Show that each of these functions is nowhere analytic:

$$(a)f(z) = xy + iy \quad (b)f(z) = 2xy + i(x^2 - y^2) \quad (c)f(z) = e^y e^{ix}$$

**Theorem:** If  $f'(z) = 0$  everywhere in a domain D, then  $f(z)$  must be constant.

**Proof:** Since  $f(z)$  is analytic. Therefore CR equations hold. i.e.

$$u_x = v_y \text{ and } u_y = -v_x$$

now let  $f(z) = u + iv \dots\dots\dots(i)$

$$\Rightarrow f'(z) = u_x + iv_x \Rightarrow 0 = u_x + iv_x \Rightarrow u_x = 0, v_x = 0 \Rightarrow u = c_1, v = c_2$$

$$\Rightarrow f(z) = c_1 + ic_2 \Rightarrow f(z) = c_3 = \text{constant}$$

**POLAR FORM OF CAUCHY RIEMANN EQUATIONS:**

We know that  $f(z) = u(x, y) + iv(x, y)$

And  $x = r\cos\theta, y = r\sin\theta$  therefore we may write

$$f(z) = u(r, \theta) + iv(r, \theta)$$

also we have  $x^2 + y^2 = r^2$  and  $\theta = \tan^{-1}\left(\frac{y}{x}\right)$

and  $u_x = v_y$  and  $v_x = -u_y$

$$\text{now } u_x = u_r r_x + u_\theta \theta_x = u_r \left(\frac{x}{r}\right) + u_\theta \left(\frac{-y}{x^2+y^2}\right) = u_r \cos\theta - u_\theta \left(\frac{\sin\theta}{r}\right)$$

$$u_y = u_r r_y + u_\theta \theta_y = u_r \left(\frac{y}{r}\right) + u_\theta \left(\frac{x}{x^2+y^2}\right) = u_r \sin\theta + u_\theta \left(\frac{\cos\theta}{r}\right)$$

$$v_x = v_r r_x + v_\theta \theta_x = v_r \left(\frac{x}{r}\right) + v_\theta \left(\frac{-y}{x^2+y^2}\right) = v_r \cos\theta - v_\theta \left(\frac{\sin\theta}{r}\right)$$

$$v_y = v_r r_y + v_\theta \theta_y = v_r \left(\frac{y}{r}\right) + v_\theta \left(\frac{x}{x^2+y^2}\right) = v_r \sin\theta + v_\theta \left(\frac{\cos\theta}{r}\right)$$

$$u_x - v_y = u_r \cos\theta - u_\theta \left(\frac{\sin\theta}{r}\right) - v_r \sin\theta - v_\theta \left(\frac{\cos\theta}{r}\right) \dots\dots\dots \text{(i)}$$

$$v_x + u_y = v_r \cos\theta - v_\theta \left(\frac{\sin\theta}{r}\right) + u_r \sin\theta + u_\theta \left(\frac{\cos\theta}{r}\right) \dots\dots\dots \text{(ii)}$$

Multiplying (i) with  $\cos\theta$  and (ii) with  $\sin\theta$  and adding

$$u_r(\cos^2\theta + \sin^2\theta) - v_\theta \frac{1}{r}(\cos^2\theta + \sin^2\theta) \Rightarrow u_r = \frac{1}{r} v_\theta$$

Multiplying (i) with  $\sin\theta$  and (ii) with  $\cos\theta$  and subtracting

$$-u_\theta \frac{1}{r}(\cos^2\theta + \sin^2\theta) - v_r(\cos^2\theta + \sin^2\theta) \Rightarrow v_r = -\frac{1}{r} u_\theta$$

Thus required CR Equations in Polar form are as follows

$$u_r = \frac{1}{r} v_\theta \text{ and } v_r = -\frac{1}{r} u_\theta$$

**LAPLACE EQUATION IN POLAR FORM**

We know that  $u_r = \frac{1}{r} v_\theta \dots\dots\dots \text{(i)}$  and  $v_r = -\frac{1}{r} u_\theta \dots\dots\dots \text{(ii)}$

Differentiating (i) with 'r' and (ii) with 'θ'

$$u_{rr} = -\frac{1}{r^2} v_\theta + \frac{1}{r} v_{r\theta} \dots\dots\dots \text{(iii)}$$

**and**  $v_{r\theta} = -\frac{1}{r} u_{\theta\theta} \Rightarrow \frac{1}{r} v_{r\theta} = -\frac{1}{r^2} u_{\theta\theta} \therefore \times \text{ing with } \frac{1}{r}$

$$\text{(iii)} \Rightarrow u_{rr} = -\frac{1}{r^2} v_\theta - \frac{1}{r^2} u_{\theta\theta}$$

$$\Rightarrow u_{rr} = -\frac{1}{r} u_r - \frac{1}{r^2} u_{\theta\theta} \quad \therefore u_r = \frac{1}{r} v_\theta$$

$$\Rightarrow u_{rr} + \frac{1}{r} u_r + \frac{1}{r^2} u_{\theta\theta} = 0 \text{ is required polar form of Laplace equation.}$$

**Remark:** Suppose that  $f(z) = u(r, \theta) + iv(r, \theta)$  be defined throughout some  $\epsilon$  neighborhood of a non-zero point  $z_0$  Then the first-order partial derivatives of  $u$  and  $v$  must exist at  $(r_0, \theta_0)$  and continuous Then they must satisfy the Cauchy-Riemann equations i.e.  $ru_r = v_\theta$  and  $u_\theta = -rv_r$  and  $f'(z)$  exists and  $f'(z) = e^{-i\theta}(u_r + iv_r)$

**Example:** Show that if CR equations hold for  $f(z) = \frac{1}{z^2}$ ;  $z \neq 0$  then  $f'(z)$  exists.

**Solution:** Given that  $f(z) = \frac{1}{z^2} = \frac{1}{(re^{i\theta})^2} = \frac{1}{r^2} e^{-i2\theta} = \frac{1}{r^2} (\cos 2\theta - i \sin 2\theta)$

Then  $u = \frac{\cos 2\theta}{r^2}$  and  $v = \frac{\sin 2\theta}{r^2}$

Then  $ru_r = -\frac{2\cos 2\theta}{r^2} = v_\theta$  and  $u_\theta = -\frac{2\sin 2\theta}{r^2} = -rv_r$

Since CR equations hold therefore  $f'(z)$  exists. And given as follows;

$$f'(z) = e^{-i\theta}(u_r + iv_r) = e^{-i\theta} \left( -\frac{2\cos 2\theta}{r^3} + i \frac{2\sin 2\theta}{r^3} \right) = -2e^{-i\theta} \frac{e^{-i2\theta}}{r^3} = -\frac{2}{(re^{i\theta})^3} = -\frac{2}{z^3}$$

**Example:** Show that for  $(z) = z^{\frac{1}{2}} = r^{\frac{1}{2}} e^{i\frac{\theta}{2}}$ ;  $f'(z)$  exists.

**Solution:** Given that  $f(z) = z^{\frac{1}{2}} = \sqrt{r} e^{i\frac{\theta}{2}} = \sqrt{r} \left( \cos \frac{\theta}{2} + i \sin \frac{\theta}{2} \right)$

Then  $u = \sqrt{r} \cos \frac{\theta}{2}$  and  $v = \sqrt{r} \sin \frac{\theta}{2}$

Then  $ru_r = \frac{\sqrt{r}}{2} \cos \frac{\theta}{2} = v_\theta$  and  $u_\theta = -\frac{\sqrt{r}}{2} \sin \frac{\theta}{2} = -rv_r$

Since CR equations hold therefore  $f'(z)$  exists. And given as follows;

$$f'(z) = e^{-i\theta}(u_r + iv_r) = e^{-i\theta} \left( \frac{1}{2\sqrt{r}} \cos \frac{\theta}{2} + i \frac{1}{2\sqrt{r}} \sin \frac{\theta}{2} \right) = \frac{1}{2\sqrt{r}} e^{-i\theta} \left( \cos \frac{\theta}{2} + i \sin \frac{\theta}{2} \right)$$

$$f'(z) = \frac{1}{2\sqrt{r}} e^{-i\theta} \cdot e^{i\frac{\theta}{2}} = \frac{1}{2\sqrt{r} e^{i\frac{\theta}{2}}} = \frac{1}{2f(z)}$$

**Exercise 20:** Show that for given  $f(z)$ ;  $f'(z)$  exists.

- $f(z) = \frac{1}{z^4}$ ;  $z \neq 0$
- $f(z) = e^{-i\theta} \cos(\ln r) + i e^{-i\theta} \sin(\ln r)$
- $f(z) = \frac{1}{z}$ ;  $z \neq 0$
- $f(z) = \sqrt[3]{r} e^{i\frac{\theta}{3}}$
- If  $n$  is real, prove that  $f(z) = r^n (\cos n\theta + i \sin n\theta)$  is analytic except  $r = 0$   
Also calculate  $f'(z)$

**ENTIRE FUNCTIONS:** A function that is analytic at each point in the entire plane.

**For example:**  $f(z) = \frac{1}{z}$ ;  $z \neq 0$  is analytic at each non-zero point in the

Finite plane and  $f'(z) = -\frac{1}{z^2}$  and it is entire. But  $f(z) = |z|^2$  is not

analytic anywhere since its derivative exists only at  $z = 0$

**Exercises 21:** (visit @ Youtube "learning with Usman Hamid")

1. Verify that each of these functions is entire:

- |  |  |
|--|--|
| (a) $f(z) = 3x + y + i(3y - x)$              | (b) $f(z) = \sin x \cosh y + i \cos x \sinh y$ |
| (c) $f(z) = e^{-y} \sin x - i e^{-y} \cos x$ | (d) $f(z) = (z^2 - 2)e^{-x} e^{-iy}$           |

2. State why a composition of two entire functions is entire.

Also, state why any linear combination  $c_1 f_1(z) + c_2 f_2(z)$  of two entire functions, where  $c_1$  and  $c_2$  are complex constants, is entire.

3. If 'g' is entire then discuss  $f(z) = (iz^2 + z)g(z)$

**REGULAR POINT:**

If a function is analytic at a point  $z_0$  and also is analytic at some point in Every neighborhood of  $z_0$  then  $z_0$  is called regular point of function.

**SINGULAR POINT (SINGULARITY):**

If a function fails to be analytic at a point  $z_0$  but is analytic at some point in Every neighborhood of  $z_0$  then  $z_0$  is called Singular point of function.

**For example:**  $z = 0$  is singular point of  $f(z) = \frac{1}{z}$

On the other hand  $f(z) = |z|^2$  has no singular points as it is nowhere analytic.

**Exercises 22: (visit @ Youtube “learning with Usman Hamid”)**

1) In each case, determine the singular points of the function and state why the function is analytic everywhere except at those points:

i.  $f(z) = \frac{2z+1}{z(z^2+1)}$

ii.  $f(z) = \frac{z^3+i}{z^2-3z+2}$

iii.  $f(z) = \frac{z^2+1}{(z+2)(z^2+2z+2)}$

iv.  $f(z) = \frac{z^3+3}{(z+1)(z^2+5)}$

**HARMONIC FUNCTIONS**

A real-valued function  $H$  of two real variables  $x$  and  $y$  is said to be *harmonic* in a given domain of the  $xy$  plane throughout that domain, if it has continuous partial derivatives of the first and second order and satisfies the partial differential equation  $H_{xx}(x, y) + H_{yy}(x, y) = 0$ , known as *Laplace’s equation*.

**Importance:** Harmonic functions play an important role in applied mathematics. For example, the temperatures  $T(x, y)$  in thin plates lying in the  $xy$  plane are Often harmonic. A function  $V(x, y)$  is harmonic when it denotes an electrostatic potential that varies only with  $x$  and  $y$  in the interior of a region of three-dimensional space that is free of charges.

**Example:** Verify that the function  $U(x, y) = e^x \text{Cos}y$  is harmonic.

**Solution:** Given that  $U(x, y) = e^x \text{Cos}y$

$$\Rightarrow U_x = e^x \text{Cos}y \quad \Rightarrow U_{xx} = e^x \text{Cos}y$$

$$\text{also } \Rightarrow U_y = -e^x \text{Sin}y \quad \Rightarrow U_{yy} = -e^x \text{Cos}y$$

$$\Rightarrow U_{xx} + U_{yy} = e^x \text{Cos}y - e^x \text{Cos}y = 0 \Rightarrow U_{xx} + U_{yy} = 0$$

$$\Rightarrow U(x, y) = e^x \text{Cos}y \text{ is harmonic.}$$

**Example:** Verify that the function  $T(x, y) = e^{-y} \sin x$  is harmonic in any domain of the  $xy$  plane and, in particular, in the semi-infinite vertical strip  $0 < x < \pi, y > 0$ .

**Solution:**

$$\begin{aligned} T_{xx}(x, y) + T_{yy}(x, y) &= 0, \\ T(0, y) &= 0, \quad T(\pi, y) = 0, \\ T(x, 0) &= \sin x, \quad \lim_{y \rightarrow \infty} T(x, y) = 0, \end{aligned}$$

which describe steady temperatures  $T(x, y)$  in a thin homogeneous plate in the  $xy$  plane that has no heat sources or sinks and is insulated except for the stated conditions along the edges.

**Theorem:** If a function  $f(z) = u(x, y) + iv(x, y)$  is analytic in a domain  $D$ , then its component functions  $u$  and  $v$  are harmonic in  $D$ .

**Proof:** Suppose that  $f$  is analytic in  $D$ , then the first-order partial derivatives of its component functions must satisfy the CR equations throughout  $D$ :

$$\text{i.e. } u_x = v_y, \text{ and } u_y = -v_x$$

Differentiating both sides of these equations with respect to  $x$ , we have

$$u_{xx} = v_{yx}, \text{ and } u_{yx} = -v_{xx}$$

Likewise, differentiation with respect to  $y$

$$u_{xy} = v_{yy}, \text{ and } u_{yy} = -v_{xy}$$

$$\text{Now } u_{xx} + u_{yy} = 0 \quad \text{and} \quad v_{xx} + v_{yy} = 0$$

That is,  $u$  and  $v$  are harmonic in  $D$ .

**Example:** The function  $f(z) = e^{-y} \sin x - ie^{-y} \cos x$  is entire, It must be harmonic in every domain of the  $xy$  plane.

**Example:** The function  $f(z) = \frac{1}{z^2} = \frac{x^2 - y^2}{(x^2 + y^2)^2} - i \frac{2xy}{(x^2 + y^2)^2}$  is

analytic at every non-zero point i.e.  $z \neq 0$  then

$u = \frac{x^2 - y^2}{(x^2 + y^2)^2}$  and  $v = \frac{-2xy}{(x^2 + y^2)^2}$  are harmonic throughout any domain

In the  $xy$  - plane that does not contain the origin.

### HARMONIC CONJUGATES (CORRESPONDING CONJUGATES)

If two given functions  $u$  and  $v$  are harmonic in a domain  $D$  and their first-order partial derivatives satisfy the Cauchy–Riemann equations throughout  $D$ , then  $v$  is said to be a **harmonic conjugate** of  $u$ .

**Remark:** A function  $f(z) = u(x, y) + iv(x, y)$  is analytic in a domain  $D$  if and only if  $v$  is a harmonic conjugate of  $u$ .

**Example:** Suppose that  $u(x, y) = x^2 - y^2$  and  $v(x, y) = 2xy$ . Since these are the real and imaginary components, respectively, of the entire Function  $f(z) = z^2$ , then  $v$  is a harmonic conjugate of  $u$  throughout the plane. But  $u$  cannot be a harmonic conjugate of  $v$  then function  $2xy + i(x^2 - y^2)$  is not analytic anywhere.

### METHOD TO FIND HARMONIC CONJUGATE:

For a given real valued function  $u(x, y)$

- i. Find  $u_x$  and then using CR equation write  $u_x = v_y$
- ii. Integrate w.r.to 'y' to get  $v(x, y)$  but a constant also appear.
- iii. Differentiate w.r.to 'x' to get  $v_x$
- iv. To find constant appear in previous step using CR equation write  $v_x = -u_y$
- v. After putting the value of constant finally get  $v(x, y)$

**Example:** Find harmonic conjugate for  $U(x, y) = e^x \text{Cos}y$

**Solution:** Given that  $U(x, y) = e^x \text{Cos}y$

$$\Rightarrow U_x = e^x \text{Cos}y \Rightarrow U_x = e^x \text{Cos}y = V_y$$

Integrate w.r.to 'y'  $\Rightarrow V(x, y) = e^x \text{Siny} + g(x)$

Differentiate w.r.to 'x'  $\Rightarrow V_x(x, y) = e^x \text{Siny} + g'(x)$

using CR equation  $\Rightarrow V_x = -U_y \Rightarrow -U_y = e^x \text{Siny} + g'(x)$

$$\Rightarrow V_x = -U_y \Rightarrow -e^x \text{Siny} = e^x \text{Siny} + g'(x) \Rightarrow g'(x) = 0 \Rightarrow g(x) = c$$

After putting the value of constant finally get

$$\Rightarrow V(x, y) = e^x \text{Siny} + c$$

**Example:** Prove that the function  $U(x, y) = e^x \text{Cos}y$  is harmonic. Find its Corresponding conjugate and construct the original function.

**Solution:** Given that  $U(x, y) = e^x \text{Cos}y$

This function is already proved in previous steps that this is Harmonic

Also we find its corresponding conjugates.

To construct original function.

Since  $\Rightarrow f(z) = U(x, y) + iV(x, y)$

$$\Rightarrow f(z) = e^x \text{Cos}y + ie^x \text{Siny} + ic \Rightarrow f(z) = e^x (\text{Cos}y + i\text{Siny}) + c'$$

$$\Rightarrow f(z) = e^x e^{iy} + c' = e^{x+iy} + c' = e^z + c' \Rightarrow f(z) = e^z + c'$$

**Exercise 23:** Prove that the given function is harmonic. Find its Corresponding conjugate and construct the original function.

- i.  $u(x, y) = x^3 - 3xy^2$
- ii.  $u(x, y) = e^x(x\text{Cos}y - y\text{Siny})$
- iii.  $u(r, \theta) = r^n \text{Cos}n\theta$
- iv.  $u(x, y) = 2x(1 - y)$
- v.  $u(x, y) = 2x - x^3 + 3xy^2$
- vi.  $u(x, y) = \sinh x \sin y$
- vii.  $u(x, y) = y/(x^2 + y^2)$



**Example:** Prove that a harmonic function satisfies the formal differential

$$\text{Equation } \frac{\partial^2 U}{\partial z \partial \bar{z}} = 0$$

**Solution:** Since  $U$  is harmonic therefor  $\frac{\partial^2 U}{\partial x^2} + \frac{\partial^2 U}{\partial y^2} = 0 \dots\dots\dots(i)$

$$\text{Since } x = \frac{z+\bar{z}}{2} \text{ and } y = \frac{z-\bar{z}}{2i}$$

$$\text{Therefore } \frac{\partial U}{\partial \bar{z}} = \frac{\partial U}{\partial x} \frac{\partial x}{\partial \bar{z}} + \frac{\partial U}{\partial y} \frac{\partial y}{\partial \bar{z}} \Rightarrow \frac{\partial U}{\partial \bar{z}} = \frac{1}{2} \frac{\partial U}{\partial x} + \frac{1}{2i} \frac{\partial U}{\partial y}$$

$$\Rightarrow \frac{\partial^2 U}{\partial z \partial \bar{z}} = \frac{\partial}{\partial z} \left( \frac{\partial U}{\partial \bar{z}} \right) = \frac{1}{2} \left( \frac{\partial^2 U}{\partial x^2} \frac{\partial x}{\partial z} + \frac{\partial^2 U}{\partial y \partial x} \frac{\partial y}{\partial z} \right) - \frac{1}{2i} \left( \frac{\partial^2 U}{\partial y \partial x} \frac{\partial x}{\partial z} + \frac{\partial^2 U}{\partial y^2} \frac{\partial y}{\partial z} \right)$$

$$\Rightarrow \frac{\partial^2 U}{\partial z \partial \bar{z}} = \frac{1}{2} \left( \frac{1}{2} \frac{\partial^2 U}{\partial x^2} - \frac{i}{2} \frac{\partial^2 U}{\partial y \partial x} \right) - \frac{1}{2i} \left( \frac{1}{2} \frac{\partial^2 U}{\partial y \partial x} + \frac{1}{2i} \frac{\partial^2 U}{\partial y^2} \right)$$

$$\Rightarrow \frac{\partial^2 U}{\partial z \partial \bar{z}} = \frac{1}{4} \frac{\partial^2 U}{\partial x^2} - \frac{i}{4} \frac{\partial^2 U}{\partial y \partial x} + \frac{i}{4} \frac{\partial^2 U}{\partial y \partial x} + \frac{1}{4} \frac{\partial^2 U}{\partial y^2}$$

$$\Rightarrow \frac{\partial^2 U}{\partial z \partial \bar{z}} = \frac{1}{4} \left( \frac{\partial^2 U}{\partial x^2} + \frac{\partial^2 U}{\partial y^2} \right) \Rightarrow \frac{\partial^2 U}{\partial z \partial \bar{z}} = 0 \quad \therefore \text{using } (i)$$

### METHOD OF CONSTRUCTING AN ANALYTIC FUNCTION;

For a given real valued function  $u(x, y)$

- i. Find  $u_x(z, 0)$  and  $u_y(z, 0)$
- ii.  $f'(z) = u_x(z, 0) - iu_y(z, 0)$
- iii. To find  $f(z)$  integrate  $f'(z)$

**Example:** Verify that the function  $U(x, y) = \text{Sin}x\text{Cos}hy$  is harmonic.

And find analytic function.

**Solution:** Given that  $U(x, y) = \text{Sin}x\text{Cos}hy$

$$\Rightarrow U_x = \text{Cos}x\text{Cos}hy \quad \Rightarrow U_{xx} = -\text{Sin}x\text{Cos}hy$$

$$\text{also } \Rightarrow U_y = \text{Sin}x\text{Siny} \quad \Rightarrow U_{yy} = \text{Sin}x\text{Cos}hy$$

$$\Rightarrow U_{xx} + U_{yy} = -\text{Sin}x\text{Cos}hy + \text{Sin}x\text{Cos}hy = 0 \Rightarrow U_{xx} + U_{yy} = 0$$

$$\Rightarrow U(x, y) = \text{Sin}x\text{Cos}hy \text{ is harmonic.}$$

$$\text{Now } u_x(z, 0) = \text{Cos}z \text{ and } u_y(z, 0) = 0$$

$$\text{Then } f'(z) = u_x(z, 0) - iu_y(z, 0) = \text{Cos}z - i0 \Rightarrow f'(z) = \text{Cos}z$$

$$\text{Integrate w.r.to 'z' } \Rightarrow f(z) = \text{Sin}z \text{ which is required.}$$

**Exercise 24:** Verify that the given function is harmonic.

And find analytic function.

- i.  $u(x, y) = \frac{x}{x^2+y^2}$
- ii.  $v(x, y) = x^3 - 3xy^2 - 5y$
- iii.  $u(x, y) = e^{-x}[(x^2 - y^2)\text{Cos}y + 2xy\text{Siny}]$
- iv.  $u(x, y) = x^3 - 3xy^2 + 3x^2 - 3y^2 + 1$
- v.  $u(x, y) = \log\sqrt{x^2 + y^2}$  in the disk  $|z - 1| < 1$
- vi.  $u(x, y) = \frac{\text{Sin}2x}{\text{Cosh}2y + \text{Cos}2x}$
- vii.  $u(x, y) = x^3 - 3xy^2 + 3x + 1$
- viii.  $u(x, y) = y^3 - 3x^2y$

**LEVEL CURVES:** A level curve of a real valued function  $U(x,y)$  defined in a Domain  $D$  is given by the locus of a point  $(x,y)$  in  $D$  such that  $U(x,y) = C$  Where  $C$  is constant.

Likewise we can consider a level curve of  $V(x,y)$  in  $D$   
i.e.  $V(x,y) = K$  Where  $K$  is constant.

**Example:** Sketch the level curves of the function  $f(z) = z^2; z \neq 0$

**Solution:** Given  $f(z) = z^2 = x^2 - y^2 + i2xy$

Put  $U(x,y) = x^2 - y^2 = C_1$  and  $V(x,y) = 2xy = C_2$

These are the required level curves and are Rectangular Hyperbolas.

**ORTHOGONAL SYSTEM:** The families of curves  $U(x,y) = C_1$  and  $V(x,y) = C_2$  Are said to form an orthogonal system if the curves intersect at right angles at each Of their point of intersection.

### CONDITION TO FIND ORTHOGONALITY OF LEVEL CURVES

Consider  $U(x,y) = C_1$

Differentiating we get  $\frac{\partial U}{\partial x} + \frac{\partial U}{\partial y} \frac{dy}{dx} = 0 \Rightarrow \frac{dy}{dx} = -\frac{\partial U}{\partial x} / \frac{\partial U}{\partial y} \Rightarrow m_1 = -\frac{\partial U}{\partial x} / \frac{\partial U}{\partial y}$

Also  $V(x,y) = C_2$

Differentiating we get  $\frac{\partial V}{\partial x} + \frac{\partial V}{\partial y} \frac{dy}{dx} = 0 \Rightarrow \frac{dy}{dx} = -\frac{\partial V}{\partial x} / \frac{\partial V}{\partial y} \Rightarrow m_2 = -\frac{\partial V}{\partial x} / \frac{\partial V}{\partial y}$

Now the two families of curves intersect orthogonally if

$$m_1 m_2 = -1 \Rightarrow \left(-\frac{\partial U}{\partial x} / \frac{\partial U}{\partial y}\right) \left(-\frac{\partial V}{\partial x} / \frac{\partial V}{\partial y}\right) = -1$$

$$\frac{\partial U}{\partial x} \frac{\partial V}{\partial x} + \frac{\partial U}{\partial y} \frac{\partial V}{\partial y} = 0 \text{ this is required condition.}$$

**Example:** If  $w = \frac{1}{z}$  then show that level curves  $U = C_1$  and  $V = C_2$

Are orthogonal circles which pass through the origin and have their centers On  $x$ -axis and  $y$ -axis.

**Solution:** Given  $w = \frac{1}{z} = \frac{\bar{z}}{z\bar{z}} = \frac{\bar{z}}{|z|^2} = \frac{x-iy}{x^2+y^2} = \frac{x}{x^2+y^2} + i \frac{-y}{x^2+y^2}$

Here  $U(x,y) = \frac{x}{x^2+y^2}$  and  $V(x,y) = \frac{-y}{x^2+y^2}$

When  $U = \frac{x}{x^2+y^2} = C_1 \Rightarrow C_1 = \frac{x}{x^2+y^2} \Rightarrow C_1(x^2 + y^2) - x = 0$  and pass through

Origin having centre  $\left(\frac{1}{2}C_1, 0\right)$

also  $V = \frac{-y}{x^2+y^2} = C_2 \Rightarrow C_2 = \frac{-y}{x^2+y^2} \Rightarrow C_2(x^2 + y^2) + y = 0$  and pass through

Origin having centre  $\left(0, \frac{1}{2}C_2\right)$

**For Orthogonality:**

$$\frac{\partial U}{\partial x} \frac{\partial V}{\partial x} + \frac{\partial U}{\partial y} \frac{\partial V}{\partial y} = \frac{y^2-x^2}{(x^2+y^2)^2} \frac{2xy}{x^2+y^2} + \frac{-2xy}{x^2+y^2} \frac{y^2-x^2}{(x^2+y^2)^2} = 0$$

Thus level curves are orthogonal.

**Example:** If  $f(z) = \frac{z+4}{z-4}$  then find the level curves  $U = C_1$  and  $V = C_2$

Also verify that level curves form an orthogonal system.

**Solution:** Given  $f(z) = \frac{z+4}{z-4} = \frac{(x+4)+iy}{(x-4)+iy} = \frac{(x^2+y^2-16)+i(-8y)}{(x-4)^2+y^2}$

Here  $U(x, y) = \frac{x^2+y^2-16}{(x-4)^2+y^2}$  and  $V(x, y) = \frac{-8y}{(x-4)^2+y^2}$

When  $U = \frac{x^2+y^2-16}{(x-4)^2+y^2} = C_1 \Rightarrow C_1(x^2 + y^2 - 8x + 16) - x^2 - y^2 + 16 = 0$

$\Rightarrow (C_1 - 1)x^2 + (C_1 - 1)y^2 - 8C_1x + 16C_1 + 16 = 0$  which is circle.

Origin having centre  $(\frac{1}{2}C_1, 0)$

Also  $V = \frac{-8y}{(x-4)^2+y^2} = C_2 \Rightarrow C_2(x^2 + y^2 - 8x + 16) + 8y = 0$  which is also circle.

**For Orthogonality:**

$$\frac{\partial U}{\partial x} \frac{\partial V}{\partial x} + \frac{\partial U}{\partial y} \frac{\partial V}{\partial y} = \frac{-8x^2+8y^2+64x-128}{[(x-4)^2+y^2]^2} \cdot \frac{16(x-4)}{[(x-4)^2+y^2]^2} + \frac{-16(x-4)}{[(x-4)^2+y^2]^2} \cdot \frac{8x^2+8y^2+64x-128}{[(x-4)^2+y^2]^2} = 0$$

Thus level curves are orthogonal.

**Example:** If  $f(z) = U + iV$  be an analytic function of  $z = x+iy$  then show that The curves  $U = C_1$  and  $V = C_2$  intersect at right angle.

**Solution:** Given  $f(z)$  to be analytic. Then CR equations hold.

i.e.  $\frac{\partial U}{\partial x} = \frac{\partial V}{\partial y} \dots \dots (i)$  and  $\frac{\partial V}{\partial x} = -\frac{\partial U}{\partial y} \dots \dots (ii)$

multiplying (i) and (ii) we get  $\frac{\partial U}{\partial x} \frac{\partial V}{\partial x} = -\frac{\partial U}{\partial y} \frac{\partial V}{\partial y}$

$\frac{\partial U}{\partial x} \frac{\partial V}{\partial x} + \frac{\partial U}{\partial y} \frac{\partial V}{\partial y} = 0$  required condition of orthogonality of two curves.

**Problem:** Prove that an analytic function with constant modulus is constant.

**Solution:** Since  $f$  is analytic in  $D$ , then it must satisfy the CR equations

i.e.  $u_x = v_y$ , and  $v_x = -u_y$  and also  $|f(z)| = C' \Rightarrow u^2 + v^2 = C \dots \dots (i)$

differentiating (i) w.r.to  $x \Rightarrow 2uu_x + 2vv_x = 0 \Rightarrow uu_x + vv_x = 0 \dots \dots (ii)$

likewise differentiating (i) w.r.to  $y \Rightarrow 2uu_y + 2vv_y = 0 \Rightarrow uu_y + vv_y = 0$

$\Rightarrow -uv_x + vu_x = 0 \dots \dots (iii)$  using CR equations.

Multiplying (ii) by 'u' and (iii) by 'v' and then adding we get

$\Rightarrow u_x(u^2 + v^2) = 0 \Rightarrow (u^2 + v^2) \neq 0$  using (i) then  $u_x = 0$

$\Rightarrow u_x = 0 = v_y \Rightarrow$  'u' is independent of  $x$  and 'v' is independent of  $y$ .

Multiplying (ii) by 'v' and (iii) by 'u' and then subtracting we get

$\Rightarrow v_x(u^2 + v^2) = 0 \Rightarrow (u^2 + v^2) \neq 0$  using (i) then  $v_x = 0$

$\Rightarrow v_x = 0 = -u_y \Rightarrow$  'v' is independent of  $x$  and 'u' is independent of  $y$ .

Thus 'u' and 'v' are both independent of  $x$  and  $y$ .

Therefore  $u$  and  $v$  are constants.

Ultimately  $f(z) = u + iv = \text{Constant}$

**Problem:** Investigate the value of  $z$  for which  $W = U + iV$  is not analytic

When  $z = \mathbf{SinhUcosV + iCoshUsinV}$

Solution: Given  $z = SinhUCosV + iCoshUsinV$

$$\Rightarrow \frac{dz}{dw} = \frac{\partial z}{\partial u} = CoshUCcosV + iSinhUsinV \dots \dots \dots (i)$$

$$\text{Also } z^2 = (SinhUcosV + iCoshUsinV)^2$$

$$z^2 = Sin^2hUcos^2V - Cos^2hUsin^2V + 2isinhUcosVcoshUsinV \dots \dots \dots (ii)$$

$$\therefore Cos^2hU - Sin^2hU = 1$$

$$(ii) \Rightarrow z^2 = (Cos^2hU - 1)cos^2V - (1 + Sin^2hU)sin^2V + 2isinhUcosVcoshUsinV$$

$$\Rightarrow z^2 = Cos^2hUcos^2V - cos^2V - sin^2hU - Sin^2hUVsin^2V + 2isinhUcosVcoshUsinV$$

$$\Rightarrow z^2 = Cos^2hUcos^2V - Sin^2hUVsin^2V + 2isinhUcosVcoshUsinV - (cos^2V + sin^2hU)$$

$$\Rightarrow z^2 = (coshUcosV + isinhUsinV)^2 - 1 \Rightarrow z^2 = \left(\frac{dz}{dw}\right)^2 - 1 \Rightarrow \left(\frac{dz}{dw}\right)^2 = 1 + z^2$$

$$\Rightarrow \frac{dw}{dz} = \pm\sqrt{1+z^2} \Rightarrow \frac{dz}{dw} = \pm\frac{1}{\sqrt{1+z^2}}$$

$$\frac{dw}{dz} \text{ does not exist when } 1 + z^2 = 0 \Rightarrow z^2 = -1 \Rightarrow z = \pm i$$

Therefore function is not analytic when  $z = \pm i$  where  $z = SinhUcosV + iCoshUsinV$

**Exercise 25: (visit @ Youtube “learning with Usman Hamid”)**

Investigate the value of  $z$  for which  $W = f(z)$  ceases to be analytic where

- i.  $z = e^{-v}(-cosu + isinu)$
- ii.  $z = SinuCoshv + iCosusinhv$

**UNIQUELY DETERMINED ANALYTIC FUNCTIONS**

Suppose that a function  $f$  is analytic throughout a domain  $D$  and  $f(z) = 0$  at each point  $z$  of a domain or line segment contained in  $D$ .

Then  $f(z) \equiv 0$  in  $D$ ; that is,  $f(z)$  is identically equal to zero throughout  $D$ .

**Remark:**

- A function that is analytic in a domain  $D$  is uniquely determined over  $D$  by its values in a domain, or along a line segment, contained in  $D$ .
- **Reflection Principle :** Suppose that a function  $f$  is analytic in some domain  $D$  which contains a segment of the  $x$  axis and whose lower half is the reflection of the upper half with respect to that axis  
Then  $\overline{f(z)} = f(\bar{z})$

**Problem:** If  $f(z) = U + iV$  is an analytic function of 'z' in any domain then prove that  $\nabla^2 |f(z)|^p = p^2 |f(z)|^{p-2} |f'(z)|^2$  also deduce for  $p = 2$ .

**Solution:** Suppose  $f(z) = U + iV$

$$\Rightarrow |f(z)| = \sqrt{U^2 + V^2} \Rightarrow |f(z)|^p = (U^2 + V^2)^{p/2} \dots\dots\dots(i)$$

$$\Rightarrow \frac{\partial}{\partial x} |f(z)|^p = \frac{p}{2} (U^2 + V^2)^{\frac{p}{2}-1} (2UU_x + 2VV_x) = p (U^2 + V^2)^{\frac{p-2}{2}} (UU_x + VV_x)$$

$$\Rightarrow \frac{\partial}{\partial x} |f(z)|^p = p (U^2 + V^2)^{\frac{p-2}{2}} (UU_x + VV_x)$$

$$\Rightarrow \frac{\partial^2}{\partial x^2} |f(z)|^p = \frac{\partial}{\partial x} \left( \frac{\partial}{\partial x} |f(z)|^p \right) = p \left( \frac{p-2}{2} \right) (U^2 + V^2)^{\frac{p-2}{2}-1} (2UU_x + 2VV_x)(UU_x + VV_x) \\ + p (U^2 + V^2)^{\frac{p-2}{2}} (UU_{xx} + U_x U_x + VV_{xx} + V_x V_x)$$

$$\Rightarrow \frac{\partial^2}{\partial x^2} |f(z)|^p = p(p-2) (U^2 + V^2)^{\frac{p-4}{2}} (UU_x + VV_x)^2 \\ + p (U^2 + V^2)^{\frac{p-2}{2}} (UU_{xx} + U_x^2 + VV_{xx} + V_x^2) \dots\dots\dots(ii)$$

Similarly

$$\Rightarrow \frac{\partial^2}{\partial y^2} |f(z)|^p = p(p-2) (U^2 + V^2)^{\frac{p-4}{2}} (UU_y + VV_y)^2 \\ + p (U^2 + V^2)^{\frac{p-2}{2}} (UU_{yy} + U_y^2 + VV_{yy} + V_y^2) \dots\dots\dots(iii)$$

Now we know that

$$\nabla^2 |f(z)|^p = \left( \frac{\partial^2}{\partial x^2} + \frac{\partial^2}{\partial y^2} \right) |f(z)|^p = \frac{\partial^2}{\partial x^2} |f(z)|^p + \frac{\partial^2}{\partial y^2} |f(z)|^p$$

Then using equation (ii) and (iii) we get

$$\nabla^2 |f(z)|^p = p(p-2) (U^2 + V^2)^{\frac{p-4}{2}} (UU_x + VV_x)^2$$

$$+ p (U^2 + V^2)^{\frac{p-2}{2}} (UU_{xx} + U_x^2 + VV_{xx} + V_x^2)$$

$$+ p(p-2) (U^2 + V^2)^{\frac{p-4}{2}} (UU_y + VV_y)^2$$

$$+ p (U^2 + V^2)^{\frac{p-2}{2}} (UU_{yy} + U_y^2 + VV_{yy} + V_y^2)$$

$$\nabla^2 |f(z)|^p = p(p-2) (U^2 + V^2)^{\frac{p-4}{2}} \left[ (UU_x + VV_x)^2 + (UU_y + VV_y)^2 \right]$$

$$+ p (U^2 + V^2)^{\frac{p-2}{2}} (UU_{xx} + U_x^2 + VV_{xx} + V_x^2 + UU_{yy} + U_y^2 + VV_{yy} + V_y^2)$$

$$\nabla^2 |f(z)|^p = p(p-2) (U^2 + V^2)^{\frac{p-4}{2}} \left[ (UU_x + VV_x)^2 + (UU_y + VV_y)^2 \right]$$

$$+ p (U^2 + V^2)^{\frac{p-2}{2}} [U(U_{xx} + U_{yy}) + V(V_{xx} + V_{yy}) + U_x^2 + V_x^2 + U_y^2 + V_y^2]$$

Since  $U_{xx} + U_{yy} = 0 = V_{xx} + V_{yy}$  and Function is analytic. Therefore CR equation Will be satisfied i.e.  $U_x = V_y$  and  $V_x = -U_y$  or  $U_y = -V_x$  then

$$\nabla^2 |f(z)|^p = p(p-2) (U^2 + V^2)^{\frac{p-4}{2}} [(UU_x + VV_x)^2 + (-UV_x + VU_x)^2]$$

$$+ p (U^2 + V^2)^{\frac{p-2}{2}} [U(0) + V(0) + U_x^2 + V_x^2 + V_x^2 + U_x^2]$$

$$= p(p-2)(U^2 + V^2)^{\frac{p-4}{2}} \left[ U^2 U_x^2 + V^2 V_x^2 + 2UVU_x V_x + U^2 V_x^2 + V^2 U_x^2 - 2UVU_x V_x \right] \\ + p(U^2 + V^2)^{\frac{p-2}{2}} [2U_x^2 + 2V_x^2]$$

$$\nabla^2 |f(z)|^p = p(p-2)(U^2 + V^2)^{\frac{p-4}{2}} [U^2(U_x^2 + V_x^2) + V^2(U_x^2 + V_x^2)] \\ + 2p(U^2 + V^2)^{\frac{p-2}{2}} [U_x^2 + V_x^2]$$

$$\nabla^2 |f(z)|^p = p(p-2)(U^2 + V^2)^{\frac{p-4}{2}} [(U_x^2 + V_x^2)(U^2 + V^2)] \\ + 2p(U^2 + V^2)^{\frac{p-2}{2}} [U_x^2 + V_x^2]$$

$$\nabla^2 |f(z)|^p = p(p-2)(U^2 + V^2)^{\frac{p-2}{2}} (U_x^2 + V_x^2) \\ + 2p(U^2 + V^2)^{\frac{p-2}{2}} [U_x^2 + V_x^2]$$

$$\nabla^2 |f(z)|^p = p(U^2 + V^2)^{\frac{p-2}{2}} (U_x^2 + V_x^2) [p-2+2]$$

$$\nabla^2 |f(z)|^p = p^2 (U^2 + V^2)^{\frac{p-2}{2}} (U_x^2 + V_x^2)$$

$$\nabla^2 |f(z)|^p = p^2 |f(z)|^{p-2} |f'(z)|^2$$

When  $p = 2$

$$\nabla^2 |f(z)|^2 = 2^2 |f(z)|^{2-2} |f'(z)|^2$$

$$\nabla^2 |f(z)|^2 = 4 |f'(z)|^2$$

### Practice:

If  $f(z)$  is an analytic function of 'z' in any domain then prove that

$$\left( \frac{\partial^2}{\partial x^2} + \frac{\partial^2}{\partial y^2} \right) |Re(f(z))|^2 = 2 |f'(z)|^2$$

**Solution:** Suppose  $f(z) = u + iv$

$$\Rightarrow |Re(f(z))| = u \Rightarrow |Re(f(z))|^2 = u^2 \Rightarrow S = u^2 \text{ (say)}$$

$$\Rightarrow S_x = 2uu_x \Rightarrow S_{xx} = 2(uu_{xx} + u_x^2) \text{ and } S_y = 2uu_y \Rightarrow S_{yy} = 2(uu_{yy} + u_y^2)$$

$$\Rightarrow S_{xx} + S_{yy} = \left( \frac{\partial^2}{\partial x^2} + \frac{\partial^2}{\partial y^2} \right) S = 2(uu_{xx} + u_x^2) + 2(uu_{yy} + u_y^2)$$

$$\Rightarrow \left( \frac{\partial^2}{\partial x^2} + \frac{\partial^2}{\partial y^2} \right) |Re(f(z))|^2 = 2[u(u_{xx} + u_{yy}) + (u_x^2 + u_y^2)]$$

$$\Rightarrow \left( \frac{\partial^2}{\partial x^2} + \frac{\partial^2}{\partial y^2} \right) |Re(f(z))|^2 = 2(u_x^2 + u_y^2) \quad \therefore u_{xx} + u_{yy} = 0$$

$$\text{Hence } \left( \frac{\partial^2}{\partial x^2} + \frac{\partial^2}{\partial y^2} \right) |Re(f(z))|^2 = 2 |f'(z)|^2$$

# CHAPTER 3

---

## ELEMENTARY FUNCTIONS

### THE EXPONENTIAL FUNCTION

We define here the exponential function  $e^z$  by writing

$$e^z = e^x e^{iy} \quad \text{where } (z = x + iy),$$

Where Euler's formula gives  $e^{iy} = \cos y + i \sin y$  and  $y$  is to be taken in radians.

**Remark:**

- i.  $e^z = \rho e^{i\varphi}$  where  $\rho = e^x$  and  $\varphi = y$
- ii.  $|e^z| = e^x$
- iii.  $\arg(e^z) = y + 2n\pi ; n = 0, \pm 1, \pm 2, \dots$
- iv.  $e^{z_1} e^{z_2} = e^{z_1+z_2}$  (addition theorem)
- v.  $\frac{e^{z_1}}{e^{z_2}} = e^{z_1-z_2}$
- vi.  $e^z \neq 0$  as  $e^x$  is never zero.
- vii.  $e^0 = 1$
- viii.  $e^{-z} = \frac{1}{e^z}$
- ix.  $\frac{d}{dz} e^z = e^z$  everywhere in the 'z' plane.
- x.  $e^{z+2\pi i} = e^z$
- xi.  $e^{\pi i} = -1$  and  $e^{2\pi i} = 1$
- xii.  $e^{(2n+1)\pi i} = -1 ; n = 0, \pm 1, \pm 2, \dots$
- xiii.  $e^z$  converges absolutely.

**Example:** Find numbers  $z = x + iy$  such that  $e^z = 1 + i$

**Solution:** Given that  $e^z = 1 + i$

$$\Rightarrow e^x e^{iy} = 1 + i$$

$$\text{Then } |e^z| = e^x = \sqrt{2} \Rightarrow x = \ln\sqrt{2} = \frac{1}{2} \ln 2$$

$$\text{and } \arg(e^z) = \theta + 2n\pi = \frac{\pi}{4} + 2n\pi = \left(2n + \frac{1}{4}\right)\pi ; n = 0, \pm 1, \pm 2, \dots$$

now we know that  $z = x + iy$

then after putting the values

$$z = x + iy = \frac{1}{2} \ln 2 + \left(2n + \frac{1}{4}\right)\pi i ; n = 0, \pm 1, \pm 2, \dots$$

**Property:** Prove that  $e^z = 1$  iff  $z = 2k\pi i$  ;  $k = 0, \pm 1, \pm 2, \dots$

**Solution:** Consider  $e^z = 1$  Then we have to prove  $z = 2k\pi i$

Now as  $e^z = 1 \Rightarrow e^x e^{iy} = 1 \Rightarrow e^x (\text{Cos}y + i\text{Sin}y) = 1$

$\Rightarrow e^x \text{Cos}y + ie^x \text{Sin}y = 1 + 0i$

$e^x \text{Cos}y = 1 \dots\dots(i)$   $e^x \text{Sin}y = 0 \dots\dots(ii)$

(ii)  $\Rightarrow e^x \neq 0 \Rightarrow \text{Sin}y = 0 \Rightarrow y = \text{Sin}^{-1}(0) \Rightarrow y = n\pi$  ;  $n = 0, \pm 1, \pm 2, \dots$

(i)  $\Rightarrow e^x \text{Cos}y = 1 \Rightarrow e^x \text{Cos}n\pi = 1 \Rightarrow e^x (-1)^n = e^0$

$\Rightarrow (-1)^n = 1$  if  $n = 2k$  ;  $k = 0, \pm 1, \pm 2, \pm 3, \dots$

Thus  $e^x = e^0 \Rightarrow x = 0$  and therefore  $y = n\pi = 2k\pi$

Hence  $z = x + iy = 2k\pi i$

**For Sufficient Condition:**

Given  $z = 2k\pi i$  then we have to show that  $e^z = 1$

Let  $e^z = e^{2k\pi i} = \text{Cos}2k\pi + i\text{Sin}2k\pi = 1 + 0$

$\Rightarrow e^z = 1$  as required

**Property:** Prove that  $e^{z_1} = e^{z_2}$  if  $z_1 = z_2 + 2k\pi i$

**Solution:** Consider  $e^{z_1} = e^{z_2}$  Then we have to prove  $z = 2k\pi i$

Now as  $e^{z_1} = e^{z_2} \Rightarrow e^{z_1 - z_2} = 1 \Rightarrow e^{(x_1 - x_2) + i(y_1 - y_2)} = 1$

$\Rightarrow e^{x_1 - x_2} [\text{Cos}(y_1 - y_2) + i\text{Sin}(y_1 - y_2)] = 1 + 0i$

$e^{x_1 - x_2} \cdot \text{Cos}(y_1 - y_2) = 1 \dots\dots(i)$   $e^{x_1 - x_2} \cdot \text{Sin}(y_1 - y_2) = 0 \dots\dots(ii)$

(ii)  $\Rightarrow e^{x_1 - x_2} \neq 0 \Rightarrow \text{Sin}(y_1 - y_2) = 0 \Rightarrow (y_1 - y_2) = \text{Sin}^{-1}(0)$

$\Rightarrow (y_1 - y_2) = n\pi$  ;  $n = 0, \pm 1, \pm 2, \dots$

(i)  $\Rightarrow e^{x_1 - x_2} \cdot \text{Cos}(y_1 - y_2) = 1 \Rightarrow e^{x_1 - x_2} \cdot \text{Cos}n\pi = 1 \Rightarrow e^{x_1 - x_2} \cdot (-1)^n = e^0$

$\Rightarrow (-1)^n = 1$  if  $n = 2k$  ;  $k = 0, \pm 1, \pm 2, \pm 3, \dots$

Thus  $e^{x_1 - x_2} = e^0 \Rightarrow x_1 - x_2 = 0 \Rightarrow x_1 = x_2$

and therefore  $z_1 - z_2 = (x_1 - x_2) + i(y_1 - y_2) = 0 + i2k\pi$

Hence  $z_1 - z_2 = 2k\pi i \Rightarrow z_1 = z_2 + 2k\pi i$

**Property:** Prove that  $e^z = -1$  iff  $z = (2k + 1)\pi i$  ;  $k = 0, \pm 1, \pm 2, \dots$

**Solution:** Consider  $e^z = -1$  Then we have to prove  $z = (2k + 1)\pi i$

Now as  $e^z = -1 \Rightarrow e^x e^{iy} = -1 \Rightarrow e^x (\text{Cos}y + i\text{Sin}y) = -1$

$\Rightarrow e^x \text{Cos}y + ie^x \text{Sin}y = -1 + 0i$

$e^x \text{Cos}y = -1 \dots\dots(i)$   $e^x \text{Sin}y = 0 \dots\dots(ii)$

(ii)  $\Rightarrow e^x \neq 0 \Rightarrow \text{Sin}y = 0 \Rightarrow y = \text{Sin}^{-1}(0) \Rightarrow y = n\pi$  ;  $n = 0, \pm 1, \pm 2, \dots$

(i)  $\Rightarrow e^x \text{Cos}y = -1 \Rightarrow e^x \text{Cos}n\pi = -1 \Rightarrow e^x (-1)^n = -e^0$

$\Rightarrow (-1)^n = -1$  if  $n = (2k + 1)$  ;  $k = 0, \pm 1, \pm 2, \pm 3, \dots$

Thus  $e^x = e^0 \Rightarrow x = 0$  and therefore  $y = n\pi = (2k + 1)\pi$

Hence  $z = x + iy = (2k + 1)\pi i$

**For Sufficient Condition:**

Given  $z = (2k + 1)\pi i$  then we have to show that  $e^z = -1$

Let  $e^z = e^{(2k+1)\pi i} = \text{Cos}(2k + 1)\pi + i\text{Sin}(2k + 1)\pi = -1 + 0i$

$\Rightarrow e^z = -1$  as required



**Property:** Prove that  $e^z = i$  iff  $z = \left(\frac{1}{2} + 2n\right)\pi i$  ;  $n = 0, \pm 1, \pm 2, \dots$

**Solution:** Consider  $e^z = i$  Then we have to prove  $z = \left(\frac{1}{2} + 2n\right)\pi i$

Now as  $e^z = i \Rightarrow e^x e^{iy} = i \Rightarrow e^x (\text{Cos}y + i\text{Sin}y) = i$

$\Rightarrow e^x \text{Cos}y + ie^x \text{Sin}y = 0 + i$

$e^x \text{Cos}y = 0 \dots\dots(i)$     $e^x \text{Sin}y = 1 \dots\dots(ii)$

(i)  $\Rightarrow e^x \neq 0 \Rightarrow \text{Cos}y = 0 \Rightarrow y = \text{Cos}^{-1}(0) \Rightarrow y = \left(\frac{1}{2} + 2n\right)\pi$

(ii)  $\Rightarrow e^x \text{Sin}y = 1 \Rightarrow e^x \text{Sin}\left(\frac{1}{2} + 2n\right)\pi = 1 \Rightarrow e^x (1)^n = e^0$

Thus  $e^x = e^0 \Rightarrow x = 0$

Hence  $z = x + iy = 0 + \left(\frac{1}{2} + 2n\right)\pi i$

**For Sufficient Condition:**

Given  $z = \left(\frac{1}{2} + 2n\right)\pi i$  then we have to show that  $e^z = i$

Let  $e^z = e^{\left(\frac{1}{2} + 2n\right)\pi i} = \text{Cos}\left(\frac{1}{2} + 2n\right)\pi + i\text{Sin}\left(\frac{1}{2} + 2n\right)\pi = 0 + i$

$\Rightarrow e^z = i$  as required

**PERIODIC FUNCTION:** A function  $f(z)$  is said to be periodic if there exists a non – zero constant  $\lambda$  (complex) such that  $f(z + \lambda) = f(z)$

Thus  $\lambda$  is called period of the function.

**Property:** Prove that  $e^z$  is periodic function.

**Solution:** if  $f(z) = e^z$  then we have to show the periodic value of  $e^z$

Consider  $f(z + \lambda) = f(z) \Rightarrow e^{z+\lambda} = e^z$

If  $z=0$  then  $\Rightarrow e^{0+\lambda} = e^0 \Rightarrow e^\lambda = 1$

Since  $\lambda$  is complex valued therefor  $\lambda = \alpha + i\beta \dots\dots\dots(i)$

Then  $e^\lambda = 1 \Rightarrow e^{\alpha+i\beta} = 1 \Rightarrow e^\alpha (\text{Cos}\beta + i\text{Sin}\beta) = 1 + 0i$

$e^\alpha \text{Cos}\beta = 1 \dots\dots(ii)$     $e^\alpha \text{Sin}\beta = 0 \dots\dots(iii)$

(iii)  $\Rightarrow e^\alpha \neq 0 \Rightarrow \text{Sin}\beta = 0 \Rightarrow \beta = \text{Sin}^{-1}(0) \Rightarrow \beta = n\pi$  ;  $n = 0, \pm 1, \pm 2, \dots$

(ii)  $\Rightarrow e^\alpha \text{Cos}\beta = 1 \Rightarrow e^\alpha \text{Cos}n\pi = 1 \Rightarrow e^\alpha (-1)^n = e^0$

$\Rightarrow (-1)^n = 1$  if  $n = 2k$  ;  $k = 0, \pm 1, \pm 2, \pm 3, \dots\dots\dots$

Thus  $e^\alpha = e^0 \Rightarrow \alpha = 0$  and therefore  $\beta = n\pi = 2k\pi$

Hence  $\lambda = \alpha + i\beta = 2k\pi i$

Now  $e^z$  is periodic functions as

$f(z) = f(z + \lambda) \Rightarrow e^z = e^{z+\lambda} = e^{z+2k\pi i} = e^z (\text{Cos}2k\pi + i\text{Sin}2k\pi)$

$\Rightarrow e^{z+\lambda} = e^z (1 + 0i) \Rightarrow e^{z+\lambda} = e^z$  Thus  $\lambda = 2k\pi i$  is period of  $e^z$

For  $k = 1$  ,  $\lambda = 2\pi i$  is Simple, Fundamental or Primitive period of  $e^z$  and the other periods are  $\lambda = 4\pi i, \lambda = 6\pi i, \lambda = 8\pi i$  etc

**Remark:** The periodicity of the exponential function does not appear in the real domain, since the periods of the function are all imaginary.

**Property:** Prove that  $\overline{(e^z)} = e^{\bar{z}}$

**Solution:** L. H. S =  $\overline{(e^z)} = \overline{(e^{x+iy})} = e^x e^{-iy} = e^x (\text{Cos}y - i\text{Sin}y)$

R. H. S =  $e^{\bar{z}} = e^{\bar{x}+i\bar{y}} = e^x e^{-iy} = e^x (\text{Cos}y - i\text{Sin}y)$

Hence the result.

**REMARK:**  $e^{\bar{z}}$  is not an analytic function because  $\bar{z}$  is involved.

### Exercises 26: (visit @ Youtube “learning with Usman Hamid”)

- i. Prove that  $\text{Exp}(iz)$  and  $\text{Exp}(-iz)$  are regular functions of ‘z’
- ii. Prove that  $e^{iz} = \text{Cos}z + i\text{Sin}z$
- iii. Prove that  $e^{-iz} = \text{Cos}z - i\text{Sin}z$
- iv. Prove that  $|e^z - 1| \leq |z|e^{|z|}$
- v. State why the function  $f(z) = 2z^2 - 3 - ze^z + e^{-z}$  is entire.
- vi. Show in two ways that the function  $f(z) = \exp(z^2)$  is entire. What is its derivative?
- vii. Show that (a)  $\exp(2 \pm 3\pi i) = -e^2$   
 (b)  $\exp\left(\frac{2+\pi i}{4}\right) = \sqrt{\frac{e}{2}}(1+i)$   
 (c)  $\exp(z + \pi i) = -\exp z$ .
- viii. show that the function  $f(z) = \exp \bar{z}$  is not analytic anywhere.
- ix. Write  $|\exp(2z + i)|$  and  $|\exp(iz^2)|$  in terms of  $x$  and  $y$ . Then show that  $|\exp(2z + i) + \exp(iz^2)| \leq e^{2x} + e^{-2xy}$
- x. Show that  $|\exp(z^2)| \leq \exp(|z|^2)$
- xi. Prove that  $|\exp(-2z)| < 1$  if and only if  $\text{Re } z > 0$
- xii. Find all values of ‘z’ such that  
 (a)  $e^z = -2$  (b)  $e^z = 1+i$  (c)  $\exp(2z - 1) = 1$
- xiii. Show that if  $e^z$  is real, then  $\text{Im } z = n\pi$  ( $n = 0, \pm 1, \pm 2, \dots$ )
- xiv. If  $e^z$  is pure imaginary, what restriction is placed on  $z$ ?
- xv. Write  $\text{Re}(e^{1/z})$  in terms of  $x$  and  $y$ . Why is this function harmonic in every domain that does not contain the origin?
- xvi. Show that  $\overline{e^{iz}} = e^{i\bar{z}} \Leftrightarrow z = n\pi$  ;  $n = 0, \pm 1, \pm 2, \dots$
- xvii. Consider the exponential function  $f(z) = e^z$  on which points it is differentiable.

## THE LOGARITHMIC FUNCTION

The multivalued logarithmic function of a nonzero complex variable  $z = re^{i\theta}$  can be defined as follows

$$\log z = \ln r + i(\theta + 2n\pi) \quad \text{or} \quad \log z = \ln |z| + i \arg(z) ; n = 0, \pm 1, \pm 2, \dots$$

The **principal value** of  $\log z$  is defined as follows

$$\text{Log } z = \ln r + i\theta \quad \text{or} \quad \text{Log } z = \ln |z| + i\theta$$

### Remarks:

- Every non-zero complex number has infinitely many logarithms which differs from one another by an integral multiple of  $2\pi i$
- 'Ln' is logarithm with base 10 i.e. common log while 'ln' is natural logarithm with base 'e'.

**Example:** if  $z = -1 - \sqrt{3}i$  then  $r = |z| = 2$  and  $\theta = -2\pi/3$  then find its logarithm.

**Solution:** Given that  $z = -1 - \sqrt{3}i$  then  $r = 2$  and  $\theta = -2\pi/3$  then using the formula we get required logarithm i.e.

$$\log z = \ln |z| + i(\theta + 2n\pi) ; n = 0, \pm 1, \pm 2, \dots$$

$$\log(-1 - \sqrt{3}i) = \ln 2 + i(-2\pi/3 + 2n\pi) ; n = 0, \pm 1, \pm 2, \dots$$

$$\log(-1 - \sqrt{3}i) = \ln 2 + 2\left(n - \frac{1}{3}\right)\pi i ; n = 0, \pm 1, \pm 2, \dots$$

**Example:** Find that  $\log 1 = 0$

**Solution:** using  $\log z = \ln |z| + i(\theta + 2n\pi) ; n = 0, \pm 1, \pm 2, \dots$

$$\log 1 = \ln 1 + i(0 + 2n\pi) = 2n\pi i \quad (n = 0, \pm 1, \pm 2, \dots).$$

As anticipated,  $\log 1 = 0$ .

**Example:** Find that  $\log(-1) = \pi i$

**Solution:** using  $\log z = \ln |z| + i(\theta + 2n\pi) ; n = 0, \pm 1, \pm 2, \dots$

$$\log(-1) = \ln 1 + i(\pi + 2n\pi) = (2n + 1)\pi i \quad (n = 0, \pm 1, \pm 2, \dots)$$

and that  $\log(-1) = \pi i$ .

**Example:** Show that  $\text{Log} [(1 + i)^2] = 2\text{Log}(1 + i)$

**Solution:** using  $\text{Log } z = \ln r + i\theta$

$$L.H.S = \text{Log} [(1 + i)^2] = \text{Log} (2i) = \ln 2 + i\frac{\pi}{2}$$

$$R.H.S = 2\text{Log}(1 + i) = 2\left(\ln\sqrt{2} + i\frac{\pi}{4}\right) = \ln 2 + i\frac{\pi}{2} \quad \text{As required.}$$

**Example:** Show that  $\text{Log} [(-1 + i)^2] \neq 2\text{Log}(-1 + i)$

**Solution:** using  $\text{Log } z = \ln r + i\theta$

$$L.H.S = \text{Log} [(-1 + i)^2] = \text{Log} (-2i) = \ln 2 - i\frac{\pi}{2}$$

$$R.H.S = 2\text{Log}(-1 + i) = 2\left(\ln\sqrt{2} + i\frac{3\pi}{4}\right) = \ln 2 + i\frac{3\pi}{2}$$

Hence the result.

**Example:** Show that  $\log (i)^2 \neq 2\log i$

**Solution:** using  $\log z = \ln |z| + i(\theta + 2n\pi)$

$$L.H.S = \log i^2 = \log (-1) = (2n + 1)\pi i \quad ; n = 0, \pm 1, \pm 2, \dots$$

$$R.H.S = 2\log i = 2\left[\ln 1 + i\left(\frac{\pi}{2} + 2n\pi\right)\right] = (4n + 1)\pi i \quad ; n = 0, \pm 1, \pm 2, \dots$$

Hence the result.

## BRANCHES AND DERIVATIVES OF LOGARITHMS

- A **branch** of a multiple-valued function  $f$  is any single-valued function  $F$  that is analytic in some domain at each point  $z$  of which the value  $F(z)$  is one of the values of  $f$ .
- The function  $\text{Log } z = \ln r + i\theta$  ( $r > 0, -\pi < \theta < \pi$ ) is called the **principal branch** of logarithmic function.
- A **branch cut** is a portion of a line or curve that is introduced in order to define a branch  $F$  of a multiple-valued function  $f$ .
- Points on the branch cut for  $F$  are singular points of  $F$ , and any point that is common to all branch cuts of  $f$  is called a **branch point**.
- The origin is evidently a branch point for branches of the multiple-valued logarithmic function.

**Example:**

Show that  $\log (i)^2 = 2\log i$  when the branch  $\text{Log } z = \ln r + i\theta$

( $r > 0, \frac{\pi}{4} < \theta < \frac{9\pi}{4}$ ) is used.

**Solution:** using  $\log z = \ln |z| + i(\theta + 2n\pi)$

$$L.H.S = \log i^2 = \log (-1) = \ln 1 + \pi i = \pi i$$

$$R.H.S = 2\log i = 2\left[\ln 1 + i\frac{\pi}{2}\right] = \pi i$$

Hence the result.

**Example:** Find the value of  $\log (-1 + i)$

**Solution:** using  $\log z = \ln |z| + i\arg(z)$

$$\log (-1 + i) = \ln \sqrt{2} + i(\pi - \pi/4)$$

$$\log (-1 + i) = \ln \sqrt{2} + \frac{3\pi}{4}i$$

**Exercises 27: (visit @ Youtube “learning with Usman Hamid”)**

1. Show that

$$(a) \operatorname{Log}(-ei) = 1 - i(\pi/2) \quad (b) \operatorname{Log}(1 - i) = \frac{1}{2} \ln 2 - \frac{\pi}{4} i$$

2. Show that

a)  $\log e = 1 + 2n\pi i \quad (n = 0, \pm 1, \pm 2, \dots)$

b)  $\log i = \left(2n + \frac{1}{2}\right) \pi i \quad (n = 0, \pm 1, \pm 2, \dots)$

c)  $\log(-1 + \sqrt{3}i) = \ln 2 + 2\left(n + \frac{1}{3}\right) \pi i \quad (n = 0, \pm 1, \pm 2, \dots)$

3. Show that  $\operatorname{Log}(i)^3 \neq 3\operatorname{Log}i$ 4. Show that  $\log(i)^2 \neq 2\log i$  when the branch  $\operatorname{Log} z = \ln r + i\theta$  ( $r > 0, \frac{3\pi}{4} < \theta < \frac{11\pi}{4}$ ) is used.5. Find all roots of the equation  $\log z = i\pi/2$ . *Ans.  $z = i$ .*6. Show that  $\operatorname{Re}[\log(z-1)] = 1/2 \ln[(x-1)^2 + y^2]$  ( $z \neq 1$ ). Why must this function satisfy Laplace's equation when  $z \neq 1$ ?7. Show that  $\log(i)^{1/2} = \frac{1}{2} \log i$ 8. Show in two ways that the function  $\ln(x^2 + y^2)$  is harmonic in every domain that does not contain the origin.9. Find that  $\log(i) = i\pi/2$ 

10.  $(-1)^{1/\pi} = e^{(2n+1)i} \quad (n = 0, \pm 1, \pm 2, \dots)$

11. Find the value of  $\operatorname{Log}(-1 - i)$ 12. Find the value of  $\operatorname{Log}(1 - i)$ 13. Find the value of  $(1 + i)^i$ 14. Find the value of  $e^{\operatorname{Log}(1+i)}$ 15. Find the value of  $(-1 + i)^i$ 16. Show that  $(1 + i)^i = \exp\left(-\frac{\pi}{4} + 2n\pi\right) \exp\left(i\frac{\ln 2}{2}\right) \quad (n = 0, \pm 1, \pm 2, \dots)$ 17. Show that  $\frac{1}{i^i} = \exp[(4n + 1)\pi] \quad (n = 0, \pm 1, \pm 2, \dots)$ 18. Find the value of  $(\sqrt{3} + i)^{i/2}$ 

19. Explain the following paradox

$$\pi i = \log(-1) = \frac{1}{2} \log(-1)^2 = \frac{1}{2} \log(0) = 0$$

### SOME IDENTITIES INVOLVING LOGARITHMS

If  $z_1$  and  $z_2$  denote any two nonzero complex numbers, then

- $\log(z_1 z_2) = \log z_1 + \log z_2$
- $\log(z_1/z_2) = \log z_1 - \log z_2$
- $\arg(z_1 z_2) = \arg z_1 + \arg z_2$
- $\ln |z_1 z_2| + i \arg(z_1 z_2) = (\ln |z_1| + i \arg z_1) + (\ln |z_2| + i \arg z_2)$
- $z^n = e^{n \log z} \quad (n = 0 \pm 1, \pm 2, \dots)$
- $z^{1/n} = \exp(1/n \log z) \quad ; n = 1, 2, 3, \dots \text{ and } z \neq 0$

**Example:** Show that  $\log(z_1 z_2) = \log z_1 + \log z_2$  when  $z_1 = z_2 = -1$

**Solution:** Since we know that  $\log 1 = 2n\pi i$  and  $\log(-1) = (2n + 1)\pi i$ , where  $n = 0, \pm 1, \pm 2, \dots$

then  $\log(z_1 z_2) = \log(1) = 2n\pi i$  and using the values  $n = 0$  we get  $\log(z_1 z_2) = 0$

and  $\log z_1 + \log z_2 = \pi i - \pi i$  for  $n = 0$  and  $n = -1$  respectively.

Then clearly  $\log(z_1 z_2) = \log z_1 + \log z_2$

But

If, on the other hand, the principal values are used then statement is not always true i.e.

$\text{Log}(z_1 z_2) = 0$  and  $\text{Log } z_1 + \text{Log } z_2 = 2\pi i$  for  $n=0$

**Property:** Prove that  $\log(z_1 z_2) = \log z_1 + \log z_2$

**Proof:** let  $z_1 = x_1 + iy_1$  and  $z_2 = x_2 + iy_2$

Then  $z_1 z_2 = (x_1 x_2 - y_1 y_2) + i(x_2 y_1 + y_2 x_1)$

Now using the formula  $\log z = \ln |z| + i \arg(z)$

$L.H.S = \log z_1 z_2 = \ln |z_1 z_2| + i \arg(z_1 z_2)$

$\log z_1 z_2 = \frac{1}{2} \ln[(x_1^2 + y_1^2)(x_2^2 + y_2^2)] + i \tan^{-1} \left( \frac{x_2 y_1 + y_2 x_1}{x_1 x_2 - y_1 y_2} \right)$

and for R.H.S consider

$\log z_1 = \ln |z_1| + i \arg(z_1) = \frac{1}{2} \ln[(x_1^2 + y_1^2)] + i \tan^{-1} \left( \frac{y_1}{x_1} \right)$

$\log z_2 = \ln |z_2| + i \arg(z_2) = \frac{1}{2} \ln[(x_2^2 + y_2^2)] + i \tan^{-1} \left( \frac{y_2}{x_2} \right)$

$R.H.S = \log z_1 + \log z_2 = \frac{1}{2} \ln[(x_1^2 + y_1^2)(x_2^2 + y_2^2)] + i \tan^{-1} \left( \frac{x_2 y_1 + y_2 x_1}{x_1 x_2 - y_1 y_2} \right)$

Hence proved.

**Property:** Prove that  $W = \log z$  is an analytic function.

**Proof:** (to prove given function is analytic we will show that function is differentiable and satisfies the CR equations.)

Let  $f(z) = W = \log z \Rightarrow f'(z) = \frac{1}{z} \Rightarrow$  Given function is differentiable.

**For CR Equations:**

Since  $f(z) = \log z \Rightarrow u + iv = \ln |z| + i \arg(z)$

$$\Rightarrow u + iv = \frac{1}{2} \ln[(x^2 + y^2)] + i \tan^{-1} \left( \frac{y}{x} \right)$$

Comparing real and imaginary parts

$$\Rightarrow u = \frac{1}{2} \ln[(x^2 + y^2)], \quad v = \tan^{-1} \left( \frac{y}{x} \right)$$

$$\Rightarrow u_x = \frac{x}{x^2 + y^2}, \quad v_y = \frac{x}{x^2 + y^2}, \quad u_y = \frac{y}{x^2 + y^2}, \quad v_x = \frac{-y}{x^2 + y^2}$$

$$\Rightarrow u_x = v_y \text{ and } u_y = -v_x$$

CR equations are satisfied. Therefore  $W = \log z$  is an analytic function.

**Example:** An identity which occurs in the quantum theory of Photoionization

$$\text{is } \left( \frac{ia-1}{ia+1} \right)^{ib} = e^{-2bcot^{-1}(a)} ; a, b \in \mathbb{R} \quad \text{verify it!!!!}$$

**Solution:**

$$\left( \frac{ia-1}{ia+1} \right)^{ib} = \exp \left[ \log \left( \frac{ia-1}{ia+1} \right)^{ib} \right] = e^{ib \log \left( \frac{ia-1}{ia+1} \right)} \quad \dots\dots\dots(i)$$

$$\text{Now consider } \log \left( \frac{ia-1}{ia+1} \right) = \log(ia-1) - \log(ia+1)$$

$$\log \left( \frac{ia-1}{ia+1} \right) = \left[ \ln |ia-1| + i \arg \left( \frac{a}{-1} \right) \right] - \left[ \ln |ia+1| + i \arg \left( \frac{a}{1} \right) \right]$$

$$\log \left( \frac{ia-1}{ia+1} \right) = \ln |ia-1| + i(\pi - \tan^{-1} a) - \ln |ia+1| - i \tan^{-1} a$$

$$\log \left( \frac{ia-1}{ia+1} \right) = i\pi - i \tan^{-1} a - i \tan^{-1} a = i\pi - 2i \tan^{-1} a$$

$$\log \left( \frac{ia-1}{ia+1} \right) = 2i \left( \frac{\pi}{2} - \tan^{-1} a \right) = 2i \cot^{-1}(a)$$

$$(i) \Rightarrow \left( \frac{ia-1}{ia+1} \right)^{ib} = e^{ib(2i \cot^{-1}(a))} = e^{-2bcot^{-1}(a)} \quad \therefore i^2 = -1$$

**Example:** Prove that  $Re[(1+i)^{\log(1+i)}] = 2^{\frac{1}{4} \log 2} \cdot e^{-\frac{\pi^2}{16}} \cdot \cos \left( \frac{\pi}{4} \log 2 \right)$

**Solution:**

$$\text{Let } (1+i)^{\log(1+i)} = \exp[\log(1+i)^{\log(1+i)}] = \exp[\log(1+i) \cdot \log(1+i)]$$

$$(1+i)^{\log(1+i)} = \exp[\log(1+i)]^2 = \exp \left[ \ln |1+i| + i \tan^{-1} \left( \frac{1}{1} \right) \right]^2$$

$$(1+i)^{\log(1+i)} = \exp \left[ \frac{1}{2} \log 2 + i \frac{\pi}{4} \right]^2$$

$$(1+i)^{\log(1+i)} = \exp \left[ \left( \frac{1}{2} \log 2 \right)^2 + \left( i \frac{\pi}{4} \right)^2 + 2 \left( \frac{1}{2} \log 2 \right) \left( i \frac{\pi}{4} \right) \right]$$

$$(1+i)^{\log(1+i)} = \exp \left[ \frac{1}{4} (\log 2)^2 - \frac{\pi^2}{16} + i \frac{\pi}{4} \log 2 \right]$$

$$(1+i)^{\log(1+i)} = \exp \left[ \frac{1}{4} (\log 2)(\log 2) - \frac{\pi^2}{16} + i \frac{\pi}{4} \log 2 \right]$$

$$(1+i)^{\log(1+i)} = e^{(\log 2)^{\frac{1}{4}}(\log 2)} \cdot e^{-\frac{\pi^2}{16}} \cdot e^{i\frac{\pi}{4}\log 2}$$

$$(1+i)^{\log(1+i)} = e^{(\log 2)^{\frac{1}{4}}(\log 2)} \cdot e^{-\frac{\pi^2}{16}} \cdot \left[ \cos\left(\frac{\pi}{4}\log 2\right) + i\sin\left(\frac{\pi}{4}\log 2\right) \right]$$

$$= e^{(\log 2)^{\frac{1}{4}}(\log 2)} \cdot e^{-\frac{\pi^2}{16}} \cdot \cos\left(\frac{\pi}{4}\log 2\right) + i e^{(\log 2)^{\frac{1}{4}}(\log 2)} \cdot e^{-\frac{\pi^2}{16}} \cdot \sin\left(\frac{\pi}{4}\log 2\right)$$

Taking only real part, we get the required.

$$\operatorname{Re}\left[(1+i)^{\log(1+i)}\right] = 2^{\frac{1}{4}\log 2} \cdot e^{-\frac{\pi^2}{16}} \cdot \cos\left(\frac{\pi}{4}\log 2\right)$$

### COMPLEX EXPONENTS (THE POWER FUNCTION)

When  $z \neq 0$  and the exponent  $c$  is any complex number, the function  $z^c$  is defined by means of the equation

$$z^c = e^{c \log z} \quad \text{where } \log z \text{ denotes the multiple-valued logarithmic function.}$$

#### Remark:

- for two functions  $f(z)$  and  $g(z)$  we can write
 
$$[f(z)]^{g(z)} = e^{\log[f(z)]^{g(z)}} = e^{g(z)\log f(z)}$$
- if ' $c$ ' is not a rational number then
 
$$e^{c \log z} = \exp\{c[\ln |z| + i(\arg(z) + 2n\pi)]\} \quad ; \quad n = 0, \pm 1, \pm 2, \dots$$
 has an infinite number of values.
- $\frac{d}{dz} z^c = \frac{d}{dz} e^{c \log z} = \frac{c}{z} e^{c \log z}$       ▪  $\frac{d}{dz} c^z = c^z \log c$
- The *principal value* of  $z^c$  occurs when  $\log z$  is replaced by  $\operatorname{Log} z$  as follows  $z^c = e^{c \operatorname{Log} z}$
- $z^c$  is analytic. As its derivative exists.
- $z^c = e^{c \log z}$  also called the *principal branch* of the function  $z^c$  on the domain  $|z| > 0, -\pi < \operatorname{Arg} z < \pi$

**Example:** Find the principal value of  $(i)^i$

**Solution:** we may write  $i^i = e^{i \log i}$

$$\text{Now as } \log i = \ln |i| + i(\arg(i) + 2n\pi) = \left(2n + \frac{1}{2}\right)\pi i \quad ; \quad n = 0, \pm 1, \pm 2, \dots$$

$$\text{Then } i^i = \exp\left[i\left(2n + \frac{1}{2}\right)\pi i\right] = \exp\left[-\left(2n + \frac{1}{2}\right)\pi\right] \quad ; \quad n = 0, \pm 1, \pm 2, \dots$$

$$\text{Then principal value will be } i^i = \exp\left(-\frac{\pi}{2}\right) \quad ; \quad n = 0, \pm 1, \pm 2, \dots$$

Note that the values of  $i^i$  are all real numbers.

**Example:** Find the principal value of  $(-1)^{1/\pi}$

**Solution:** we may write  $(-1)^{1/\pi} = e^{\frac{1}{\pi} \log(-1)}$

$$\text{Now } \log(-1) = \ln |-1| + i(\arg(-1) + 2n\pi) = (2n + 1)\pi i$$

$$\text{Then } (-1)^{1/\pi} = \exp\left[\frac{1}{\pi}(2n + 1)\pi i\right] = \exp[(2n + 1)i] \quad ; \quad n = 0, \pm 1, \pm 2, \dots$$



**Example:** Find the principal branch of  $z^{2/3}$

**Solution:** we may write  $z^{2/3} = e^{\frac{2}{3}\log z}$

Now  $\log z = \ln |z| + i \arg(z)$

Then  $z^{2/3} = e^{\frac{2}{3}\log z} = \exp\left[\frac{2}{3}\ln |z| + i\frac{2}{3}\arg\right]$

$z^{2/3} = \exp\left[\frac{2}{3}\ln r + i\frac{2}{3}\theta\right] = \exp\left[\ln\sqrt[3]{r^2} + i\frac{2}{3}\theta\right]$

$z^{2/3} = \sqrt[3]{r^2} \exp\left(i\frac{2\theta}{3}\right) = \sqrt[3]{r^2} \left[\cos\frac{2\theta}{3} + i\sin\frac{2\theta}{3}\right]$ , principal value.

This function is analytic in the domain  $r > 0$ ,  $\pi < \theta < \pi$

**Example:** Evaluate  $\text{Lne}^{(1+\frac{3}{2}\pi i)}$  (this is common logarithm)

**Solution:** we may write  $\text{Lne}^{(1+\frac{3}{2}\pi i)} = \log_e^{(1+\frac{3}{2}\pi i)}$

$\log_e^{(1+\frac{3}{2}\pi i)} = \log\left(e^1 \cdot e^{\frac{3}{2}\pi i}\right) = \log e^1 + \log e^{\frac{3}{2}\pi i}$

$\log_e^{(1+\frac{3}{2}\pi i)} = 1 + \log\left[\cos\frac{3}{2}\pi + i\sin\frac{3}{2}\pi\right] = 1 + \log[0 - i] = \log(-i)$

$\text{Lne}^{(1+\frac{3}{2}\pi i)} = 1 - i\frac{\pi}{2}$

**Example:** Consider the nonzero complex numbers  $z_1 = 1 + i$ ,  $z_2 = 1 - i$   
then show that  $(z_1 z_2)^i = z_1^i z_2^i$

**Solution:**

When principal values of the powers are taken,

$(z_1 z_2)^i = 2^i = e^{i\text{Log } 2} = e^{i(\ln 2 + i0)} = e^{i \ln 2}$

And

$z_1^i = e^{i\text{Log}(1+i)} = e^{i(\ln\sqrt{2} + i\pi/4)} = e^{-\pi/4} e^{i(\ln 2)/2}$

$z_2^i = e^{i\text{Log}(1-i)} = e^{i(\ln\sqrt{2} - i\pi/4)} = e^{\pi/4} e^{i(\ln 2)/2}$

Thus  $(z_1 z_2)^i = z_1^i z_2^i$

**Example:** Consider the nonzero complex numbers  $z_2 = 1 - i$ ,  $z_3 = -1 - i$ .  
then show that  $(z_2 z_3)^i = z_2^i z_3^i e^{-2\pi}$

**Solution:**

When principal values of the powers are taken,

$(z_2 z_3)^i = (-2)^i = e^{i\text{Log}(-2)} = e^{i(\ln 2 + i\pi)} = e^{-\pi} e^{i \ln 2}$

And

$z_3^i = e^{i\text{Log}(-1-i)} = e^{i(\ln\sqrt{2} - i3\pi/4)} = e^{3\pi/4} e^{i(\ln 2)/2}$

$z_2^i = e^{i\text{Log}(1-i)} = e^{i(\ln\sqrt{2} - i\pi/4)} = e^{\pi/4} e^{i(\ln 2)/2}$

Thus  $(z_2 z_3)^i = z_2^i z_3^i e^{-2\pi}$

**Exercises 28: (visit @ Youtube “learning with Usman Hamid”)**

1) Find the principal value of

(a)  $(-i)^i$

(c)  $(1-i)^{4i}$

(b)  $\left[ \frac{e}{2}(-1 - \sqrt{3}i) \right]^{3\pi i}$

(d)  $(-1)^{2i}$

2) Show that  $(-1 + \sqrt{3}i)^{3/2} = \pm 2\sqrt{2}$ .

3) Show that the results;

a)  $(-1 + \sqrt{3}i)^{3/2} = [(-1 + \sqrt{3}i)^3]^{1/2}$  finding the square roots of  $-1 + \sqrt{3}i$ b)  $(-1 + \sqrt{3}i)^{3/2} = [(-1 + \sqrt{3}i)^{1/2}]^3$  finding the cube roots of  $-1 + \sqrt{3}i$ 4) Find all the solutions of  $W = i^i$  and prove that the values can be arranged in an infinite geometric progression.5) Examine the validity of the equation  $\log z^4 = 4 \log z$  by taking different values of ‘z’6) Prove that  $\sum_{n=0}^{\infty} \frac{(1+\pi i)^n}{n!} = -e$ **TRIGONOMETRIC FUNCTIONS**The sine and cosine functions of a complex variable  $z$  are defined asfollows:  $\text{Sin}z = \frac{e^{iz} - e^{-iz}}{2i}$  and  $\text{Cos}z = \frac{e^{iz} + e^{-iz}}{2}$ **Remark**

- $e^{iz} = \cos z + i \sin z$
- $\sin(iy) = i \sinh y$  and  $\cos(iy) = \cosh y$
- $\sin z = \sin x \cosh y + i \cos x \sinh y$
- $\cos z = \cos x \cosh y - i \sin x \sinh y$
- $|\text{Sin}z|^2 = \text{Sin}^2x + \text{Sin}^2hy$
- $|\text{Cos}z|^2 = \text{Cos}^2x + \text{Sin}^2hy$
- $\text{Sin}z$  and  $\text{Cos}z$  are not bounded on the complex plane.
- The zeros of  $\text{Sin}z$  and  $\text{Cos}z$  in the complex plane are same as the zeros of  $\text{Sin}x$  and  $\text{Cos}x$  on the real line (discussed in next theorems)
- $|\text{Sin}z| \geq |\text{Sin}x|$  and  $|\text{Cos}z| \geq |\text{Cos}x|$

**Property:**  $\text{Sin}z$  is periodic function with primitive period  $2\pi$ .**Proof:**For periodic function we have  $f(z + \lambda) = f(z)$  then

$$\text{Sin}(z + \lambda) = \text{Sin}(z)$$

Put  $z = 0 \Rightarrow \text{Sin}(\lambda) = \text{Sin}(0) \Rightarrow \text{Sin}\lambda = 0 \Rightarrow \lambda = n\pi \dots\dots\dots(i)$

Now as we have  $\text{Sin}(z + \lambda) = \text{Sin}(z)$ 

$$\Rightarrow \text{Sin}(z + n\pi) = \text{Sin}(z)$$

$$\Rightarrow \text{Sin}z \text{Cos}n\pi + \text{Cos}z \text{Sin}n\pi = \text{Sin}(z) \Rightarrow \text{Sin}z(-1)^n + \text{Cos}z(0) = \text{Sin}(z)$$

$$\Rightarrow \text{Sin}z(-1)^n = \text{Sin}(z) \text{ this condition will hold if 'n' is even. i.e. } n = 2k$$

$$(i) \Rightarrow \lambda = 2k\pi \quad ; k = 0, \pm 1, \pm 2, \dots\dots\dots$$

Hence  $\text{Sin}z$  is periodic function with primitive period  $2\pi$ .

**Property:**  $\text{Cos}z$  is periodic function with primitive period  $2\pi$ .

**Proof:** For periodic function we have  $f(z + \lambda) = f(z)$  then

$$\text{Cos}(z + \lambda) = \text{Cos}(z)$$

$$\text{Put } z = 0 \Rightarrow \text{Cos}(\lambda) = \text{Cos}(0) \Rightarrow \text{Cos}\lambda = 1 \Rightarrow \lambda = n\pi \dots\dots\dots(i)$$

$$\text{Now as we have } \text{Cos}(z + \lambda) = \text{Cos}(z)$$

$$\Rightarrow \text{Cos}(z + n\pi) = \text{Cos}(z)$$

$$\Rightarrow \text{Cos}z\text{Cos}n\pi - \text{Sin}z\text{Sin}n\pi = \text{Cos}(z) \Rightarrow \text{Cos}z(-1)^n + \text{Sin}z(0) = \text{Cos}(z)$$

$$\Rightarrow \text{Cos}z(-1)^n = \text{Cos}(z) \text{ this condition will hold if 'n' is even. i.e. } n = 2k$$

$$(i) \Rightarrow \lambda = 2k\pi \quad ; k = 0, \pm 1, \pm 2, \dots\dots\dots$$

Hence  $\text{Cos}z$  is periodic function with primitive period  $2\pi$ .

### Zero of a Function:

The values of 'z' for which  $f(z) = 0$  are called zeros of  $f(z)$

**Property:**  $\text{Sin}z = 0 \Leftrightarrow z = n\pi ; n = 0, \pm 1, \pm 2, \dots\dots$  Or find zeros of  $\text{Sin}z$ .

**Proof:** consider  $\text{Sin}z = 0$

$$\Rightarrow \text{Sin}(x + iy) = 0 \Rightarrow \text{Sin}x\text{Cos}iy + \text{Cos}x\text{Sin}iy = 0$$

$$\Rightarrow \text{Sin}x\text{Cosh}y + i\text{Cos}x\text{Sin}hy = 0 + 0i$$

$$\Rightarrow \text{Sin}x\text{Cosh}y = 0 \dots\dots\dots(i) \quad \text{Cos}x\text{Sin}hy = 0 \dots\dots\dots(ii)$$

$$(i) \Rightarrow \text{Cosh}y \neq 0, \text{Sin}x = 0 \Rightarrow x = n\pi$$

$$(ii) \Rightarrow \text{Cos}x\text{Sin}hy = 0 \Rightarrow \text{Cos}n\pi\text{Sin}hy = 0 \Rightarrow (-1)^n\text{Sin}hy = 0$$

$$\Rightarrow (-1)^n \neq 0, \text{Sin}hy = 0 \Rightarrow \frac{1}{2}[e^y - e^{-y}] = 0 \Rightarrow [e^y - e^{-y}] = 0$$

$$\Rightarrow e^{2y} = 1 = e^0 \Rightarrow y = 0$$

Now we know that  $z = x + iy$  therefore  $z = n\pi ; n = 0, \pm 1, \pm 2, \dots\dots$

**Conversely:** consider  $z = n\pi$  Then  $\text{Sin}z = \text{Sin}n\pi = 0$  as required.

**Property:**  $\text{Cos}z = 0 \Leftrightarrow z = \frac{(2n+1)\pi}{2} ; n = 0, \pm 1, \pm 2, \dots\dots$

Or find zeros of  $\text{Cos}z$ .

**Proof:** consider  $\text{Cos}z = 0$

$$\Rightarrow \text{Cos}(x + iy) = 0 \Rightarrow \text{Cos}x\text{Cos}iy - \text{Sin}x\text{Sin}iy = 0$$

$$\Rightarrow \text{Cos}x\text{Cosh}y - i\text{Sin}x\text{Sin}hy = 0 + 0i$$

$$\Rightarrow \text{Cos}x\text{Cosh}y = 0 \dots\dots\dots(i) \quad \text{Sin}x\text{Sin}hy = 0 \dots\dots\dots(ii)$$

$$(i) \Rightarrow \text{Cosh}y \neq 0, \text{Cos}x = 0 \Rightarrow x = \frac{(2n+1)\pi}{2}$$

$$(ii) \Rightarrow \text{Sin}x\text{Sin}hy = 0 \Rightarrow \text{Sin}\frac{(2n+1)\pi}{2} \cdot \text{Sin}hy = 0 \Rightarrow 1 \cdot \text{Sin}hy = 0$$

$$\Rightarrow \text{Sin}hy = 0 \Rightarrow \frac{1}{2}[e^y - e^{-y}] = 0 \Rightarrow [e^y - e^{-y}] = 0$$

$$\Rightarrow e^{2y} = 1 = e^0 \Rightarrow y = 0$$

Now we know that  $z = x + iy$  therefore  $z = \frac{(2n+1)\pi}{2} ; n = 0, \pm 1, \pm 2, \dots\dots$

**Conversely:** consider  $z = \frac{(2n+1)\pi}{2}$  Then  $\text{Cos}z = \text{Cos}\frac{(2n+1)\pi}{2} = 0$  as required.

**Problem:** Find all solutions to  $\text{Sinz} = 2i$

**Proof:** consider  $\text{Sinz} = 2i$

$$\Rightarrow \text{Sin}(x + iy) = 2i \Rightarrow \text{Sin}x\text{Cos}iy + \text{Cos}x\text{Sin}iy = 2i$$

$$\Rightarrow \text{Sin}x\text{Cosh}y + i\text{Cos}x\text{Sin}hy = 0 + 2i$$

$$\Rightarrow \text{Sin}x\text{Cosh}y = 0 \dots\dots(i) \quad \text{Cos}x\text{Sin}hy = 2 \dots\dots(ii)$$

$$(i) \Rightarrow \text{Cosh}y \neq 0, \text{Sin}x = 0 \Rightarrow x = n\pi$$

$$(ii) \Rightarrow \text{Cos}x\text{Sin}hy = 2 \Rightarrow \text{Cos}n\pi\text{Sin}hy = 2 \Rightarrow (-1)^n\text{Sin}hy = 2$$

$$\Rightarrow (-1)^n \neq 0, \text{Sin}hy = 2 \Rightarrow \frac{1}{2}[e^y - e^{-y}] = 2 \Rightarrow e^y - e^{-y} = 4$$

$$\Rightarrow e^{2y} - 4e^y - 1 = 0 \Rightarrow e^y = 2 \pm \sqrt{5} \text{ by quadratic formula.}$$

$$\Rightarrow y = \log(2 \pm \sqrt{5})$$

Now we know that  $z = x + iy$  therefore  $z = n\pi + i\log(2 \pm \sqrt{5})$

**Problem:** Find all solutions to  $\text{Cos}z = 5$

**Proof:** consider  $\text{Cos}z = 5$

$$\Rightarrow \text{Cos}(x + iy) = 5 \Rightarrow \text{Cos}x\text{Cos}iy - \text{Sin}x\text{Sin}iy = 5$$

$$\Rightarrow \text{Cos}x\text{Cosh}y - i\text{Sin}x\text{Sin}hy = 5 + 0i$$

$$\Rightarrow \text{Cos}x\text{Cosh}y = 5 \dots\dots(i) \quad \text{Sin}x\text{Sin}hy = 0 \dots\dots(ii)$$

$$(ii) \Rightarrow \text{Sin}hy \neq 0, \text{Sin}x = 0 \Rightarrow x = n\pi$$

$$(i) \Rightarrow \text{Cos}n\pi\text{Cosh}y = 5 \Rightarrow (-1)^n\text{Cosh}y = 5$$

$$\Rightarrow (-1)^n \neq 0, \text{Cosh}y = 5 \Rightarrow \frac{1}{2}[e^y + e^{-y}] = 5 \Rightarrow e^y + e^{-y} = 10$$

$$\Rightarrow e^{2y} - 10e^y + 1 = 0 \Rightarrow e^y = 5 \pm 2\sqrt{6} \text{ by quadratic formula.}$$

$$\Rightarrow y = \log(5 \pm 2\sqrt{6})$$

Now we know that  $z = x + iy$  therefore  $z = n\pi + i\log(5 \pm 2\sqrt{6})$

**Exercises 29: (visit @ Youtube “learning with Usman Hamid”)**

1) Show that  $|\sin z| \geq |\sin x|$ ; and  $|\cos z| \geq |\cos x|$ .

2) Show that  $|\sinh y| \leq |\sin z| \leq \cosh y$ ; and  $|\sinh y| \leq |\cos z| \leq \cosh y$ .

3) Show that neither  $\sin \bar{z}$  nor  $\cos \bar{z}$  is an analytic function of  $z$  anywhere.

4) Find all roots of the equation  $\sin z = \cosh 4$  by equating the real parts and then the imaginary parts of  $\sin z$  and  $\cosh 4$ .

5) Find all solutions to  $\text{Sinz} = 5$

6) Find all solutions to  $\text{Cos}z = 2$

## HYPERBOLIC FUNCTIONS

For a complex variable  $z$  we can define:

$$\text{Sinh}z = \frac{e^z - e^{-z}}{2} \quad \text{and} \quad \text{Cosh}z = \frac{e^z + e^{-z}}{2}$$

### Remark

- $e^z = \text{sinh}z + \text{cosh}z$
- $\text{sinh}(iz) = i \sin z \quad \text{and} \quad \text{cosh}(iz) = \cos z$
- $|\text{Sinh}z|^2 = \text{Sin}^2hx + \text{Sin}^2y$
- $|\text{Cosh}z|^2 = \text{Sin}^2hx + \text{Cos}^2y$
- $\text{Sinh}z$  and  $\text{Cosh}z$  are both analytic.
- $-i \text{sinh}(iz) = \sin z, \quad \text{cosh}(iz) = \cos z$
- $-i \sin(iz) = \sinh z, \quad \cos(iz) = \cosh z$
- Hyperbolic functions are analytic except for those values of 'z' which are excluded by definition.

### Property:

$\text{Sinh}z = 0 \Leftrightarrow z = n\pi i ; n = 0, \pm 1, \pm 2, \dots$ . Or find zeros of  $\text{Sinh}z$ .

**Proof:** consider  $\text{Sinh}z = 0$

$$\Rightarrow \frac{e^z - e^{-z}}{2} = 0 \Rightarrow e^z - e^{-z} = 0 \Rightarrow e^z = e^{-z} \Rightarrow e^{2z} = e^0 = 0 = e^{2n\pi i}$$

$$\Rightarrow 2z = 2n\pi i \Rightarrow z = n\pi i ; n = 0, \pm 1, \pm 2, \dots$$

**Conversely:** consider  $z = n\pi i$

Then  $\text{Sinh}z = \text{Sinh}n\pi i = i \text{Sinn}\pi = 0$  as required. Since  $\text{sinh}(iz) = i \sin z$

### Property:

$\text{Cosh}z = 0 \Leftrightarrow z = \left(\frac{\pi}{2} + n\pi\right) i ; n = 0, \pm 1, \pm 2, \dots$ . Or find zeros of  $\text{Cosh}z$ .

**Proof:** consider  $\text{Cosh}z = 0$

$$\Rightarrow \frac{e^z + e^{-z}}{2} = 0 \Rightarrow e^z + e^{-z} = 0 \Rightarrow e^z = -e^{-z}$$

$$\Rightarrow e^{2z} = -e^0 = -1 = e^{2\left(\frac{\pi}{2} + n\pi\right) i} \Rightarrow 2z = 2\left(\frac{\pi}{2} + n\pi\right) i \Rightarrow z = \left(\frac{\pi}{2} + n\pi\right) i$$

$$; n = 0, \pm 1, \pm 2, \dots$$

**Conversely:** consider  $z = \left(\frac{\pi}{2} + n\pi\right) i$

Then  $\text{Cosh}z = \text{Cosh}\left(\frac{\pi}{2} + n\pi\right) i = \text{Cos}\left(\frac{\pi}{2} + n\pi\right) = 0$  as required. Since

$$\text{cosh}(iz) = \cos z$$

**Property:**  $\text{Sinh}z$  is periodic function with primitive period  $2k\pi i$ .

**Proof:** For periodic function we have  $f(z + \lambda) = f(z)$  then

$$\text{Sinh}(z + \lambda) = \text{Sinh}(z)$$

$$\text{Put } z = 0 \Rightarrow \text{Sinh}(\lambda) = \text{Sinh}(0) \Rightarrow \text{Sinh}\lambda = 0 \Rightarrow \frac{e^\lambda - e^{-\lambda}}{2} = 0 \Rightarrow e^\lambda - e^{-\lambda} = 0$$

$$\Rightarrow e^{2\lambda} = e^0 = 0 = e^{2n\pi i} \Rightarrow 2\lambda = 2n\pi i \Rightarrow \lambda = n\pi i ; n = 2k \text{ i.e. Even}$$

$$\Rightarrow \text{Sinh}(z + \lambda) = \text{Sinh}(z + n\pi i) = \text{Sinh}(z + 2k\pi i) = \text{Sinh}(z)$$

Hence  $\text{Sinh}z$  is periodic function with primitive period  $2k\pi i$ .

**Property:**  $\text{Cosh}z$  is periodic function with primitive period  $2k\pi i$ .

**Proof:** For periodic function we have  $f(z + \lambda) = f(z)$  then

$$\text{Cosh}(z + \lambda) = \text{Cosh}(z)$$

$$\text{Put } z = 0 \Rightarrow \text{Cosh}(\lambda) = \text{Cosh}(0) \Rightarrow \text{Cosh}\lambda = 1 \Rightarrow \lambda = \text{Cosh}^{-1}(1) = n\pi i$$

$$\Rightarrow \lambda = n\pi i ; n = 2k \text{ i.e. Even}$$

$$\Rightarrow \text{Cosh}(z + \lambda) = \text{Cosh}(z + n\pi i) = \text{Cosh}(z + 2k\pi i) = \text{Cosh}(z)$$

Hence  $\text{Cosh}z$  is periodic function with primitive period  $2k\pi i$ .

**Problem:** Find all solutions to  $\text{Sinhz} = -i$

**Proof:** consider  $\text{Sinhz} = -i$

$$\Rightarrow \text{Sinh}(x + iy) = -i \Rightarrow \text{Sinh}x\text{Cosh}iy - \text{Cosh}x\text{Sinh}iy = -i$$

$$\Rightarrow \text{Sinh}x\text{Cos}y - i\text{Cosh}x\text{Sin}y = 0 - i$$

$$\Rightarrow \text{Sinh}x\text{Cos}y = 0 \dots\dots(i) \quad \text{Cosh}x\text{Sin}y = 1 \dots\dots(ii)$$

$$(i) \Rightarrow \text{Sinh}x \neq 0, \text{Cos}y = 0 \Rightarrow y = (2n + 1)\frac{\pi}{2}$$

$$(ii) \Rightarrow \text{Cosh}x\text{Sin}(2n + 1)\frac{\pi}{2} = 1$$

Now two cases arises;

**Case – I :** when  $\text{Sin}(2n + 1)\frac{\pi}{2} = -1$

$$\Rightarrow \text{Cosh}x.(-1) = 1 \Rightarrow \text{Cosh}x = -1 \Rightarrow \frac{e^x + e^{-x}}{2} = -1 \Rightarrow e^x + e^{-x} = -2$$

$$\Rightarrow e^x = -1 \Rightarrow x = \log(-1) \text{ not possible.}$$

**Case – II :** when  $\text{Sin}(2n + 1)\frac{\pi}{2} = 1$

$$\Rightarrow \text{Cosh}x.1 = 1 \Rightarrow \text{Cosh}x = 1 \Rightarrow \frac{e^x + e^{-x}}{2} = 1 \Rightarrow e^x + e^{-x} = 2$$

$$\Rightarrow e^x = 1 \Rightarrow x = \log(1) \Rightarrow x = 0$$

$$\text{Hence } z = x + iy = 0 + (2n + 1)\frac{\pi}{2}i \Rightarrow z = (2n + 1)\frac{\pi}{2}i$$

**Exercises 30: (visit @ Youtube “learning with Usman Hamid”)**

1. Why is the function  $\sinh(e^z)$  entire? Write its real component as a function of  $x$  and  $y$ , and state why that function must be harmonic everywhere.
2. Prove that  $|\text{Sinhz}|^2 = \text{Sinh}^2x + \text{Sin}^2y$
3. Prove that  $|\text{Cos}z|^2 = \text{Sinh}^2x + \text{Cos}^2y$
4. Prove that  $\text{Tanz} = \frac{\text{Sin}2x + i\text{Sinh}2y}{\text{Cos}2x + \text{Cosh}2y}$
5. Prove that if  $\text{Tanh}(x + iy) = u + iv$  then  $u = \frac{\text{Sinh}2x}{\text{Cos}2x + \text{Cosh}2y}$  and  $v = \frac{\text{Sin}2y}{\text{Cos}2x + \text{Cosh}2y}$
6. Find all solutions to  $\text{Sinhz} = -1$
7. Find all solutions to  $\text{Sinhz} = i$
8. Find all solutions to  $\text{Cosh}z = \frac{1}{2}$
9. Find all solutions to  $\text{Cosh}z = -2$

## INVERSE TRIGONOMETRIC AND HYPERBOLIC FUNCTIONS

- In order to define the **inverse sine function**  $\sin^{-1} z$ ,  
we write  $w = \sin^{-1} z$  when  $z = \sin w$ .

$$z = \frac{e^{iw} - e^{-iw}}{2i} \Rightarrow e^{iw} - e^{-iw} = 2iz \Rightarrow (e^{iw})^2 - 2ize^{iw} - 1 = 0$$

Then  $e^{iw} = iz \pm (1 - z^2)^{1/2}$  by quadratic formula.

Or  $e^{iw} = z \pm i(1 - z^2)^{1/2}$  by quadratic formula.

where  $(1 - z^2)^{1/2}$  is, of course, a double-valued function of  $z$ .

Taking logarithms of each side of above equation

$$\log(e^{iw}) = \log(iz \pm \sqrt{1 - z^2})$$

$$\Rightarrow iw = \log(iz \pm \sqrt{1 - z^2})$$

$$\sin^{-1} z = -i \log[iz \pm (1 - z^2)^{1/2}] \quad \text{where } w = \sin^{-1} z$$

$$\sin^{-1} z = -i \log[iz \pm (1 - z^2)^{1/2}] + n\pi \quad \text{where } (n = 0, \pm 1, \pm 2, \dots). \text{ in general}$$

Remember that  $\sin^{-1} z$  is a multiple-valued function, with infinitely many values at each point  $z$ .

- In order to define the **inverse cosine function**  $\cos^{-1} z$ ,  
we write  $w = \cos^{-1} z$  when  $z = \cos w$ .

$$z = \frac{e^{iw} + e^{-iw}}{2} \Rightarrow e^{iw} + e^{-iw} = 2z \Rightarrow (e^{iw})^2 - 2ze^{iw} + 1 = 0$$

Then  $e^{iw} = z \pm i(1 - z^2)^{1/2}$  by quadratic formula.

Or  $e^{iw} = z \pm i(1 - z^2)^{1/2}$  by quadratic formula.

where  $(1 - z^2)^{1/2}$  is, of course, a double-valued function of  $z$ .

Taking logarithms of each side of above equation

$$\log(e^{iw}) = \log(z \pm i\sqrt{1 - z^2})$$

$$\Rightarrow iw = \log(z \pm i\sqrt{1 - z^2})$$

$$\cos^{-1} z = -i \log[z \pm i(1 - z^2)^{1/2}] \quad \text{where } w = \cos^{-1} z$$

$$\cos^{-1} z = -i \log[z \pm i(1 - z^2)^{1/2}] + n\pi \quad \text{where } (n = 0, \pm 1, \pm 2, \dots). \text{ in general}$$

- In order to define the **inverse tangent function**  $\tan^{-1} z$ ,  
we write  $w = \tan^{-1} z$  when  $z = \tan w$ .

$$z = \frac{e^{iw} - e^{-iw}}{i(e^{iw} + e^{-iw})} \Rightarrow \frac{e^{iw} + e^{-iw}}{e^{iw} - e^{-iw}} = \frac{1}{iz}$$

$$\frac{e^{iw} + e^{-iw} + e^{iw} - e^{-iw}}{e^{iw} + e^{-iw} - e^{iw} + e^{-iw}} = \frac{1+iz}{1-iz} \Rightarrow \frac{2e^{iw}}{2e^{-iw}} = \frac{1+iz}{1-iz} \Rightarrow e^{2iw} = \frac{1+iz}{1-iz}$$

$$2iw = \log\left(\frac{1+iz}{1-iz}\right) \Rightarrow w = \frac{1}{2i} \log\left(\frac{1+iz}{1-iz}\right) = \frac{i}{2} \log\left(\frac{i+z}{i-z}\right)$$

$$\tan^{-1} z = \frac{i}{2} \log\left(\frac{i+z}{i-z}\right)$$

$$\tan^{-1} z = \frac{i}{2} \log\left(\frac{i+z}{i-z}\right) + n\pi \quad \text{where } (n = 0, \pm 1, \pm 2, \dots). \text{ in general}$$

Remember that  $\tan^{-1} z$  is a multiple-valued function, and each branch is single valued in  $z$ -plane, cut along the imaginary axes except from the argument from  $i$  to  $-i$

**Example:** This example shows that  $\sin^{-1}z$  is multivalued.

Show that  $\text{Sin}^{-1}(-i) = n\pi + i(-1)^{n+1}\ln(1 + \sqrt{2})$  ;  $n = 0, \pm 1, \pm 2, \dots$

**Proof:**

Since we know that  $\sin^{-1}z = -i \log[iz + (1 - z^2)^{1/2}]$

Thus  $\text{Sin}^{-1}(-i) = -i \log(1 \pm \sqrt{2})$

But  $\log(1 + \sqrt{2}) = \ln(1 + \sqrt{2}) + 2n\pi i$  ;  $n = 0, \pm 1, \pm 2, \dots$

Also  $\log(1 - \sqrt{2}) = \ln(\sqrt{2} - 1) + (2n + 1)\pi i$  ;  $n = 0, \pm 1, \pm 2, \dots$

Thus  $\log(1 \pm \sqrt{2}) = (-1)^n \ln(1 + \sqrt{2}) + n\pi i$  ;  $n = 0, \pm 1, \pm 2, \dots$

Hence  $\text{Sin}^{-1}(-i) = n\pi + i(-1)^{n+1}\ln(1 + \sqrt{2})$  ;  $n = 0, \pm 1, \pm 2, \dots$

**Remember** in this question we use

$$\ln(\sqrt{2} - 1) = \ln \frac{1}{1 + \sqrt{2}} = -\ln(1 + \sqrt{2})$$

**Remark**

- $\text{Sinh}^{-1}z = \log(z + \sqrt{z^2 + 1})$
- $\text{Cosh}^{-1}z = \log(z + \sqrt{z^2 - 1})$
- $\text{Tanh}^{-1}z = \frac{1}{2} \log \left( \frac{1+z}{1-z} \right)$

**Exercises 31: (visit @ Youtube “learning with Usman Hamid”)**

1. Find all the values of

(a)  $\tan^{-1}(2i)$  (b)  $\tan^{-1}(1+i)$  (c)  $\cosh^{-1}(-1)$  (d)  $\tanh^{-1} 0$ .

2. Solve the equation  $\sin z = 2$  for  $z$  by

- i. equating real parts and then imaginary parts in that equation;
- ii. using expression for  $\sin^{-1}z$

3. Solve the equation  $\text{Cos } z = \sqrt{2}$  for  $z$  by

- i. using expression for  $\sin^{-1}z$
- ii. using expression for  $\cos^{-1}z$
- iii. using expression for  $\tan^{-1}z$
- iv. using expression for  $\cosh^{-1}$

4. Find  $\text{Sin}^{-1}\sqrt{5}$



## CHAPTER

## 4

## INTEGRALS

Integrals are extremely important in the study of functions of a complex variable. The theory of integration, to be developed in this chapter, is noted for its mathematical elegance. The theorems are generally concise and powerful, and many of the proofs are short.

**DERIVATIVES OF FUNCTIONS  $w(t)$** 

In order to introduce integrals of  $f(z)$  in a fairly simple way, we need to first consider derivatives of complex-valued functions  $w$  of a *real* variable ' $t$ '. For a complex valued function  $w(t) = u(t) + iv(t)$ , where the functions  $u$  and  $v$  are *real-valued* functions of  $t$ . The derivative of the function is defined as  $w'(t)$  or  $\frac{d}{dt}w(t)$  or  $w'(t) = u'(t) + iv'(t)$

**Example.**

For a function  $w(t) = u(t) + iv(t)$ , show that  $\frac{d}{dt}[w(t)]^2 = 2w(t)w'(t)$

**Solution.**

Consider  $[w(t)]^2 = [u(t) + iv(t)]^2 = u^2 - v^2 + 2iuv$

$$\frac{d}{dt}[w(t)]^2 = [u^2 - v^2]' + 2i[uv]' = 2uu' - 2vv' + 2i[uv' + u'v]$$

$$\frac{d}{dt}[w(t)]^2 = 2(u + iv)(u' + iv') = 2w(t)w'(t)$$

**Example.** For  $z_0 = x_0 + iy_0$ , show that  $\frac{d}{dt}e^{z_0t} = z_0e^{z_0t}$

**Solution.**

Consider  $e^{z_0t} = e^{(x_0+iy_0)t} = e^{x_0t}e^{iy_0t} = e^{x_0t}\text{Cos}y_0t + ie^{x_0t}\text{Siny}_0t$

$$\frac{d}{dt}e^{z_0t} = [e^{x_0t}\text{Cos}y_0t]' + i[e^{x_0t}\text{Siny}_0t]'$$

$$\frac{d}{dt}e^{z_0t} = (x_0 + iy_0)(e^{x_0t}\text{Cos}y_0t + ie^{x_0t}\text{Siny}_0t)$$

$$\frac{d}{dt}e^{z_0t} = (x_0 + iy_0)e^{x_0t}e^{iy_0t}$$

$$\frac{d}{dt}e^{z_0t} = z_0e^{z_0t}$$

**Example:** Suppose that  $w(t)$  is continuous on an interval  $a \leq t \leq b$ ; that is, its component functions  $u(t)$  and  $v(t)$  are continuous there. Even if  $w'(t)$  exists when  $a < t < b$ , the mean value theorem for derivatives no longer applies. To be precise, it is not necessarily true that there is a number 'c' in the interval  $a < t < b$  such that  $w'(c) = \frac{w(b)-w(a)}{b-a}$ .  
Verify!!!!!!!!!!

**Solution.**

To see this, consider the function  $w(t) = e^{it}$  on the interval  $0 \leq t \leq 2\pi$ .

When that function is used,  $|w'(t)| = |ie^{it}| = 1$ ;

and this means that the derivative  $w'(c)$  is never zero,

while  $w(2\pi) - w(0) = 0$ .

Then

$$\frac{w(b)-w(a)}{b-a} = \frac{w(2\pi)-w(0)}{2\pi-0} = \frac{0}{2\pi} = 0$$

So there is no number 'c' such that given expression holds.

**Exercise: (visit @ Youtube "learning with Usman Hamid")**

Use rules in calculus to establish the following rules when  $w(t) = u(t) + iv(t)$  is a complex-valued function of a real variable  $t$  and  $w'(t)$  exists:

- a)  $\frac{d}{dt}[z_0 w(t)] = z_0 w'(t)$  For  $z_0 = x_0 + iy_0$  a complex constant.
- b)  $\frac{d}{dt}[w(-t)] = -w'(-t)$  where  $w'(-t)$  denotes the derivative of  $w(-t)$  with respect to 't' evaluated at '-t'

## DEFINITE INTEGRALS OF FUNCTIONS $w(t)$

When  $w(t)$  is a complex-valued function of a real variable  $t$  and is written  $w(t) = u(t) + iv(t)$ , where  $u$  and  $v$  are real-valued, the definite integral of  $w(t)$  over an interval  $a \leq t \leq b$  is defined as

$$\int_a^b w(t) dt = \int_a^b u(t) dt + i \int_a^b v(t) dt$$

Provided the individual integrals on the right exist.

### Remarks:

- i.  $Re \int_a^b w(t) dt = \int_a^b Re[w(t)] dt$  and  $Im \int_a^b w(t) dt = \int_a^b Im[w(t)] dt$
- ii. Improper integrals of  $w(t)$  over unbounded intervals are defined in a similar way.
- iii. The existence of the integrals of  $u$  and  $v$  in definition is ensured if those functions are *piecewise continuous* on the interval  $a \leq t \leq b$ . Such a function is continuous everywhere in the stated interval except possibly for a finite number of points where, although discontinuous.
- iv. The ***fundamental theorem of calculus***, involving antiderivatives, can, moreover, be extended so as to apply to integrals. To be specific, suppose that the functions  $w(t) = u(t) + iv(t)$  and  $W(t) = U(t) + iV(t)$  are continuous on the interval  $a \leq t \leq b$ . If  $W'(t) = w(t)$  when  $a \leq t \leq b$ , then  $U'(t) = u(t)$  and  $V'(t) = v(t)$ . Hence, in view of definition
 
$$\int_a^b w(t) dt = [U(t)]_a^b + i[V(t)]_a^b = [U(b) + iV(b)] - [U(a) + iV(a)]$$
 Then  $\int_a^b w(t) dt = W(b) - W(a) = [W(t)]_a^b$
- v. We know that the mean value theorem for derivatives in calculus does not carry over to complex-valued functions  $w(t)$ . Similarly, the mean value theorem for *integrals* does not carry over either. Thus special care must continue to be used in applying rules from calculus.
- vi. Definite integrals of a real variable does not extend straight way to the domain of complex variable. Whereas in case of complex variables the path of definite integral may be along any curve joining the points.

**Example:** Evaluate  $\int_0^{\pi/4} e^{it} dt$

**Solution:**

$$\int_0^{\pi/4} e^{it} dt = \int_0^{\pi/4} (\text{Cost} + i\text{Sint}) dt$$

$$\int_0^{\pi/4} e^{it} dt = \int_0^{\pi/4} \text{Cost} dt + i \int_0^{\pi/4} \text{Sint} dt = |\text{Sint}|_0^{\pi/4} - i|\text{Cost}|_0^{\pi/4}$$

$$\int_0^{\pi/4} e^{it} dt = \frac{1}{\sqrt{2}} + i \left( -\frac{1}{\sqrt{2}} + 1 \right)$$

**Another method:**

$$\int_0^{\pi/4} e^{it} dt = \left| \frac{e^{it}}{i} \right|_0^{\pi/4} = \frac{e^{i\pi/4}}{i} - \frac{e^0}{i} = \frac{1}{i} \left( \text{Cos} \frac{\pi}{4} + i\text{Sin} \frac{\pi}{4} \right) - \frac{1}{i}$$

$$\int_0^{\pi/4} e^{it} dt = \frac{1}{i} \left( \frac{1}{\sqrt{2}} + \frac{i}{\sqrt{2}} + 1 \right) = \frac{1}{\sqrt{2}} + \frac{1}{i} \left( \frac{1}{\sqrt{2}} + 1 \right)$$

$$\int_0^{\pi/4} e^{it} dt = \frac{1}{\sqrt{2}} + i \left( -\frac{1}{\sqrt{2}} + 1 \right) \quad \therefore \frac{1}{i} = -i$$

**Example:**

Suppose that  $w(t)$  is continuous on an interval  $a \leq t \leq b$ ; that is, then show that, it is not necessarily true that there is a number 'c' in the interval  $a < t < b$  such that  $\int_a^b w(t) dt = w(c)(b - a)$ .

**Solution.**

To see this, consider the function  $w(t) = e^{it}$  on the interval  $0 \leq t \leq 2\pi$ . With  $a = 0, b = 2\pi$

$$\text{Then } \int_a^b w(t) dt = \int_0^{2\pi} e^{it} dt = \left| \frac{e^{it}}{i} \right|_0^{2\pi} = 0$$

But for any number 'c' such that  $0 < c < 2\pi$

$$|w(c)(b - a)| = |e^{ic}| 2\pi$$

Thus  $L.H.S \neq R.H.S$

Hence the result.

**Exercise 32: (visit @ Youtube “learning with Usman Hamid”)**

1. Evaluate the following integrals;

a)  $\int_0^1 (1 + it)^2 dt$

b)  $\int_1^2 \left(\frac{1}{t} - i\right)^2 dt$

c)  $\int_0^{\pi/6} e^{i2t} dt$

d)  $\int_0^{\infty} e^{-zt} dt \quad (\operatorname{Re} z > 0)$

2. Show that if ‘m’ and ‘n’ are integers then

$$\int_0^{2\pi} e^{im\theta} e^{-in\theta} d\theta = \begin{cases} 0 & \text{when } m \neq n \\ 2\pi & \text{when } m = n \end{cases}$$

3. If we have  $\int_0^{\pi} e^{(1+i)x} dx = \int_0^{\pi} e^x \cos x dx + i \int_0^{\pi} e^x \sin x dx$  then

Evaluate the two integrals on the right here by evaluating the single integral on the left and then using the real and imaginary parts of the value found.

4. Let  $w(t) = u(t) + iv(t)$  denote a continuous complex-valued function defined on an interval  $-a \leq t \leq a$ .

a. Suppose that  $w(t)$  is *even*; that is,  $w(-t) = w(t)$  for each point  $t$  in the given interval. Show that

$$\int_{-a}^a w(t) dt = 2 \int_0^a w(t) dt$$

b. Show that if  $w(t)$  is an *odd* function, that is

$w(-t) = -w(t)$  for each point  $t$  in the given interval, then

$$\int_{-a}^a w(t) dt = 0$$

**Suggestion:** In each part of this exercise, use the corresponding property of integrals of *real-valued* functions of  $t$ , which is graphically evident.

---

## CONTOURS

---

Integrals of complex-valued functions of a complex variable are defined on curves in the complex plane, rather than on just intervals of the real line. Classes of curves that are adequate for the study of such integrals are introduced in this section.

### SUB DIVISION OF THE INTERVAL [a,b]

Suppose  $[a,b]$  be a closed interval and  $a, b \in R$  and divide  $[a,b]$  into  $n$  – subintervals as  $[a = t_0, t_1], [t_1, t_2], \dots, [t_{n-1}, t_n = b]$  where  $t_0, t_1, t_2, t_3, \dots, t_{n-1}, t_n$  are intermediate points between  $a = t_0$  and  $t_n = b$  such that  $a = t_0 < t_1 < t_2 < \dots < t_{n-1} < t_n = b$  then the set  $S = \{t_0, t_1, t_2, \dots, t_{n-1}, t_n\}$  is called the subdivision of the interval  $[a,b]$

### NORM OF SUB DIVISION OF THE INTERVAL [a,b]

Suppose  $[a,b]$  be a closed interval and  $a, b \in R$  and divide  $[a,b]$  into  $n$  – subintervals as  $[a = t_0, t_1], [t_1, t_2], \dots, [t_{n-1}, t_n = b]$  where  $t_0, t_1, t_2, \dots, t_{n-1}, t_n$  are intermediate points between  $a = t_0$  and  $t_n = b$  then the greatest of the numbers  $t_1 - t_0, t_2 - t_1, \dots, t_n - t_{n-1}$  is called the norm of the subdivision ‘S’ and is usually denoted by  $|S|$  or  $\|S\|$  and it is the maximum length of the subintervals of an interval  $[a,b]$

### LOCUS OF A POINT

It is a path traced by a point moving under certain given conditions.

### ARC / CURVE

A set of points  $z = (x, y)$  in the complex plane is said to be an *arc/ curve* if

$$x = x(t), \quad y = y(t) \quad (a \leq t \leq b),$$

where  $x(t)$  and  $y(t)$  are continuous functions of the real parameter  $t$ . It is the locus of the point whose coordinates can be expressed in the form of a single parameter.

For example:

- i.  $x = r\cos\theta, y = r\sin\theta \Rightarrow x^2 + y^2 = r^2$  defines a circle.
- ii.  $x = a\cos\theta, y = b\sin\theta \Rightarrow \frac{x^2}{a^2} + \frac{y^2}{b^2} = 1$  defines an ellipse.

**Keep in mind:** arc and curve are different but we use here in same manner. As curvature of arc remains fixed while curvature of curve vary with its length.

This definition establishes a continuous mapping of the interval  $a \leq t \leq b$  into the  $xy$ , or  $z$ , plane; and the image points are ordered according to increasing values of  $t$ . It is convenient to describe the points of  $C$  by means of the equation  $z = z(t) \quad (a \leq t \leq b)$ , where  $z(t) = x(t) + iy(t)$ .

### CLOSED ARC / CLOSED CURVE

A curve traced by a function  $z = z(t)$  such that the initial point and the terminal point are the same then the curve is called a closed curve. e.g. circle or ellipse.

### SIMPLE ARC / SIMPLE CURVE

The arc  $C$  is a *simple arc*, if it does not cross itself ; that is,  $C$  is simple if  $z(t_1) \neq z(t_2)$  when  $t_1 \neq t_2$

### JORDAN ARC / JORDAN CURVE

Named for C. Jordan (1838–1922), pronounced *jor-don*

A curve which is simple as well as closed is called Jordan curve.

Or When the arc  $C$  is simple except for the fact that  $z(b) = z(a)$ , we say that  $C$  is a *simple closed curve*, or a **Jordan curve**. Such a curve is *positively oriented* when it is in the counterclockwise direction.

The geometric nature of a particular arc often suggests different notation for the parameter  $t$  in equation  $z = z(t)$  ( $a \leq t \leq b$ ).

This is, in fact, the case in the following examples.

**Example:** The polygonal line defined by means of the equation

$$z = \begin{cases} x + ix & \text{when } 0 \leq x \leq 1 \\ x + i & \text{when } 1 \leq x \leq 2 \end{cases}$$

and consisting of a line segment from 0 to  $1 + i$  followed by one from  $1 + i$  to  $2 + i$  (Fig.) is a simple arc.

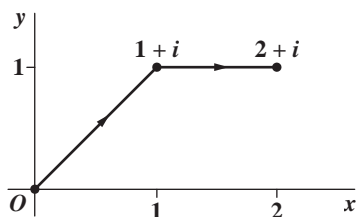

**Example:** The unit circle  $z = e^{i\theta}$  ( $0 \leq \theta \leq 2\pi$ ) about the origin is a simple closed curve, oriented in the counterclockwise direction. So is the circle  $z = z_0 + Re^{i\theta}$  ( $0 \leq \theta \leq 2\pi$ ), centered at the point  $z_0$  and with radius  $R$ .

- **The same set of points can make up different arcs.**

**Example:** The arc  $z = e^{-i\theta}$  ( $0 \leq \theta \leq 2\pi$ ) is not the same as the arc described by equation  $z = e^{i\theta}$  ( $0 \leq \theta \leq 2\pi$ ). The set of points is the same, but now the circle is traversed in the *clockwise* direction.

**Example:** The points on the arc  $z = e^{i2\theta}$  ( $0 \leq \theta \leq 2\pi$ ) are the same as those making up the arcs  $z = e^{i\theta}$  ( $0 \leq \theta \leq 2\pi$ ) and  $z = e^{-i\theta}$  ( $0 \leq \theta \leq 2\pi$ ). The arc here differs, however, from each of those arcs since the circle is traversed *twice* in the counterclockwise direction.

**Remark:** The parametric representation used for any given arc  $C$  is, of course, not unique. It is, in fact, possible to change the interval over which the parameter ranges to any other interval.

For an arc  $C$  representing by  $z = z(t)$  if we have  $z'(t) = x'(t) + iy'(t)$  Then arc is then called a *differentiable arc*, and the real-valued function

$|z'(t)| = \sqrt{|x'(t)|^2 + |y'(t)|^2}$  is integrable over the interval  $(a \leq t \leq b)$ .

### SMOOTH CURVE

If  $z = z(t)$  be a complex valued function and a curve is traced in the interval  $I = [a, b]$ , Further if  $z'(t)$  exists and  $z'(t) \neq 0$  also continuous on the closed interval then we say that  $z = z(t)$  is forming a **smooth curve or regular curve**.

### PIECEWISE SMOOTH (ARC) CURVE / CONTOUR

A *contour*, or piecewise smooth arc, is an arc consisting of a finite number of smooth arcs joined end to end.

Hence if equation  $z = z(t)$  ( $a \leq t \leq b$ ) represents a contour,  $z(t)$  is continuous, whereas its derivative  $z'(t)$  is piecewise continuous.

For example, The polygonal line defined by means of the equation

$$z = \begin{cases} x + ix & \text{when } 0 \leq x \leq 1 \\ x + i & \text{when } 1 \leq x \leq 2 \end{cases}$$

and consisting of a line segment from 0 to  $1 + i$  followed by one from  $1 + i$  to  $2 + i$  (Fig.) is a contour.

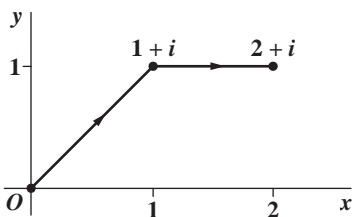

### INVERSE OF THE CURVE

If the curve  $C$  is traced by  $z = f(t)$  in the interval  $I = (a, b)$  then the inverse of  $C$  is denoted by  $\bar{C}$  which is traced by  $z = g(t)$  such that  $g(t) = (a + b - t)$ .

Both contours  $C$  and  $\bar{C}$  are the inverse of each other but represents the same curves traced in opposite direction



**Remark:**

The length of a contour or a simple closed contour is the sum of the lengths of the smooth arcs that make up the contour.

The points on any simple closed curve or simple closed contour  $C$  are boundary points of two distinct domains, one of which is the interior of  $C$  and is bounded. The other, which is the exterior of  $C$ , is unbounded. It will be convenient to accept this statement, known as the **Jordan curve theorem**, as geometrically evident; the proof is not easy.

**CONTOUR INTEGRALS**

We turn now to integrals of complex-valued functions  $f$  of the complex variable  $z$ . Such an integral is defined in terms of the values  $f(z)$  along a given contour  $C$ , extending from a point  $z = z_1$  to a point  $z = z_2$  in the complex plane. It is, therefore, a line integral; and its value depends, in general, on the contour  $C$  as well as on the function  $f$ .

Suppose that the equation  $z = z(t)$  ( $a \leq t \leq b$ ) represents a contour  $C$ , extending from a point  $z_1 = z(a)$  to a point  $z_2 = z(b)$ . We assume that  $f[z(t)]$  is *piecewise continuous* on the interval  $a \leq t \leq b$  and refer to the function  $f(z)$  as being piecewise continuous on  $C$ . We then define the line integral, or *contour integral*, of  $f$  along  $C$  in terms of the parameter  $t$

$$\int_C f(z) dz = \int_a^b f[z(t)] z'(t) dt$$

Note that since  $C$  is a contour,  $z'(t)$  is also piecewise continuous on  $a \leq t \leq b$ ; Definite integrals in calculus can be interpreted as areas, and they have other interpretations as well. Except in special cases, no corresponding helpful interpretation, geometric or physical, is available for integrals in the complex plane.

If  $C$  has the representation  $z = z(t)$  ( $a \leq t \leq b$ ) then representation for the  $-C$  is  $z = z(-t)$  ( $a \leq t \leq b$ ) given as follow

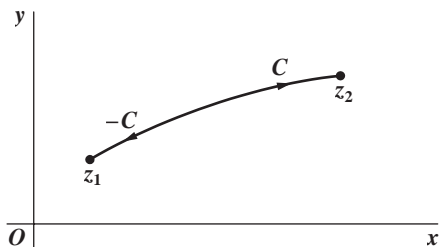

Also if  $C_1$  is the contour from  $z_1$  to  $z_2$  and  $C_2$  is the contour from  $z_2$  to  $z_3$  then the resulting contour will be called a **Sum** and can be written as  $C = C_1 + C_2$

**PROPERTIES:**

In stating properties of contour integrals we assume that all functions  $f(z)$  and  $g(z)$  are piecewise continuous on any contour used.

- i.  $\int_c z_0 f(z) dz = z_0 \int_c f(z) dz$
- ii.  $\int_c [f(z) + g(z)] dz = \int_c f(z) dz + \int_c g(z) dz$
- iii.  $\int_{-c} f(z) dz = \int_{-b}^{-a} f[z(-t)] \frac{d}{dt} z(-t) dt = - \int_{-b}^{-a} f[z(-t)] z'(-t) dt$
- iv.  $\int_{-c} f(z) dz = - \int_a^b f[z(\tau)] z'(\tau) d\tau$  for  $\tau = -t$
- v.  $\int_{-c} f(z) dz = - \int_c f(z) dz$
- vi.  $\int_c f(z) dz = \int_{C_1} f(z) dz + \int_{C_2} f(z) dz$  for  $C = C_1 + C_2$
- vii.  $\int_c f(z) dz = \int_{C_1} f(z) dz + \int_{C_2} f(z) dz + \dots + \int_{C_n} f(z) dz$

**INTEGRATION CAN BE REGARDED AS SUMMATION:**

Let  $f(z)$  be a complex valued function in the interval  $I = [a, b]$  then

$$\int_a^b f(z) dz = \int_{a=t_0}^{t_1} f(z) dz + \int_{t_1}^{t_2} f(z) dz + \dots + \int_{t_{n-1}}^{t_n=b} f(z) dz$$

And  $\lim_{\alpha \rightarrow 0} \sum_{k=1}^n f(z_k) \Delta z_k = \int_c f(z) dz$

Where  $\Delta z_k = z_k - z_{k-1}$  and  $\alpha = \max(S_1, S_2, \dots, S_n)$

**REDUCTION OF COMPLEX INTEGRAL INTO REAL INTEGRAL:**

Let  $f(z)$  be a complex valued function i.e.  $f(z) = U(x, y) + iV(x, y)$  and  $z = x + iy$  also  $dz = dx + idy$  then

$$\int_c f(z) dz = \int_c (U + iV)(x + idy)$$

$$\int_c f(z) dz = \int_c (Udx - Vdy) + i \int_c (Udy + Vdx) \quad \text{after solving}$$

**Property:** Let the function  $f(z)$  is piecewise continuous on any curve  $C$  then  $\int_{\bar{c}} f(z) dz = - \int_c f(z) dz$  where  $\bar{c}$  denotes the curve  $C$  traversed in the negative direction.

**Proof:**

Since we know that  $\int_c f(z) dz = \lim_{\alpha \rightarrow 0} \sum_{j=1}^n f(z_{n-j+1}) (z_{n-j} - z_{n-j+1})$

$$\int_{\bar{c}} f(z) dz = \lim_{\alpha \rightarrow 0} \sum_{j=1}^n f(z_j) (z_{j-1} - z_j) \quad \text{putting } n = 2j - 1$$

$$\int_{\bar{c}} f(z) dz = - \lim_{\alpha \rightarrow 0} \sum_{j=1}^n f(z_j) (z_j - z_{j-1}) = - \int_c f(z) dz$$

$$\text{Thus } \int_{\bar{c}} f(z) dz = - \int_c f(z) dz$$

**LINEARITY PROPERTY:**

Let the functions  $f(z)$  and  $g(z)$  are piecewise continuous on any contour then

$$\int_c [\alpha f(z) + \beta g(z)] dz = \alpha \int_c f(z) dz + \beta \int_c g(z) dz$$

Proof:

$$L. H. S = \int_c [\alpha f(z) + \beta g(z)] dz = \lim_{\alpha \rightarrow 0} \sum_{k=1}^n [\alpha f(z) + \beta g(z)] \Delta z_k$$

$$= \alpha \lim_{\alpha \rightarrow 0} \sum_{k=1}^n f(z) \Delta z_k + \beta \lim_{\alpha \rightarrow 0} \sum_{k=1}^n g(z) \Delta z_k$$

$$= \alpha \int_c f(z) dz + \beta \int_c g(z) dz = R. H. S$$

$$\text{Thus } \int_c [\alpha f(z) + \beta g(z)] dz = \alpha \int_c f(z) dz + \beta \int_c g(z) dz$$

**SOME EXAMPLES**

The purpose of this and the next section is to provide examples of the definition of contour integrals and to illustrate various properties that were mentioned.

**Example:**

Let C be any piecewise smooth curve joining two points  $z_n$  and  $z_0$  then prove that

$$\int_c z^n dz = \frac{1}{n+1} [z_n^{n+1} - z_0^{n+1}] \text{ and } n \neq -1 \text{ where 'n' is an integer and C does not go through the point } z = 0 \text{ if 'n' is negative}$$

**Solution:** Suppose C (curve from  $z_0$  to  $z_n$ ) has been traced by  $z = z(t)$  and is a piecewise function. So  $dz = z'(t) dt$  then

$$\int_c z^n dz = \int_{z_0}^{z_n} [z(t)]^n z'(t) dt = \left| \frac{[z(t)]^{n+1}}{n+1} \right|_{z_0}^{z_n} = \frac{1}{n+1} [z_n^{n+1} - z_0^{n+1}] \text{ for } n \neq -1$$

This equation does not depend upon the particular curve C joining points from  $z_0$  to  $z_n$ .

$$\text{If 'z' is closed curve then } \oint_c z^n dz = \frac{1}{n+1} [z_0^{n+1} - z_0^{n+1}] = 0 \Rightarrow \oint_c z^n dz = 0$$

$$\text{If } n = 0 \text{ then } \int_c z^0 dz = \int_{z_0}^{z_n} dz = |z|_{z_0}^{z_n} = z_n - z_0$$

**Example:** Evaluate  $\int_0^{1+i} z^2 dz$  where C consists of OA, AB, OB, OAB and OABO.

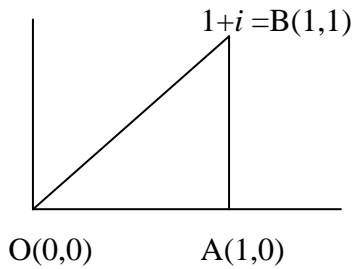

**Solution:** Let  $z = x + iy \Rightarrow dz = dx + idy$  then

$$\int_0^{1+i} z^2 dz = \int_0^{1+i} (x + iy)^2 (dx + idy) = \int_0^{1+i} (x^2 - y^2 + i2xy)(dx + idy)$$

**integral along  $\overrightarrow{OA}$ :**

for this put  $y = 0 \Rightarrow dy = 0, x = t \Rightarrow dx = dt$  where  $0 \leq t \leq 1$

$$\int_{c_1} z^2 dz = \int_0^1 t^2 dt = \left| \frac{t^3}{3} \right|_0^1 = \frac{1}{3}$$

**integral along  $\overrightarrow{AB}$ :**

for this put  $x = 1 \Rightarrow dx = 0, y = t \Rightarrow dy = dt$  where  $0 \leq t \leq 1$

$$\int_{c_2} z^2 dz = \int_0^1 (1 - t^2 + i2t)(idt) = i \int_0^1 (1 - t^2 + i2t) dt = \frac{1}{3}[-3 + 2i]$$

**integral along  $\overrightarrow{OB}$ :**

for this put  $x = t \Rightarrow dx = dt, y = t \Rightarrow dy = dt$  where  $0 \leq t \leq 1$

$$\int_{c_3} z^2 dz = \int_0^1 (t^2 - t^2 + i2t^2)(dt + idt) = \frac{2}{3}[-1 + i]$$

**integral along  $\overrightarrow{OAB}$ :**

$$\int_{c_4} z^2 dz = \int_{c_1} z^2 dz + \int_{c_2} z^2 dz = \frac{1}{3} + \frac{1}{3}[-3 + 2i] = -\frac{2}{3} + \frac{2}{3}i$$

**integral along  $\overrightarrow{OABO}$ :**

$$\int_0^{1+i} z^2 dz = \int_{c_4} z^2 dz - \int_{c_3} z^2 dz = -\frac{2}{3} + \frac{2}{3}i + \frac{2}{3} - \frac{2}{3}i = 0$$

Since the contour is closed therefore its integral is zero.

**Example:**

Prove that the value of the integral  $\int_c \frac{1}{z} dz$  when  $C$  is a semicircular arc  $|z| = 1$  from  $-1$  to  $1$  is  $-\pi i$  or  $\pi i$  according as the arc lies above or below the real axis.

**Solution:**

Since we know that for a unit circle  $z = e^{i\theta} \Rightarrow dz = ie^{i\theta} d\theta$

**Case – I :** Consider the circle above real axis from  $-1$  to  $1$

$$I_1 = \int_{\pi}^0 \frac{1}{z} dz = -i \int_0^{\pi} e^{-i\theta} e^{i\theta} d\theta = -i \int_0^{\pi} d\theta = -\pi i$$

**Case – II :** Consider the circle below real axis from  $-1$  to  $1$

$$I_2 = \int_{\pi}^{2\pi} \frac{1}{z} dz = i \int_{\pi}^{2\pi} e^{-i\theta} e^{i\theta} d\theta = i \int_{\pi}^{2\pi} d\theta = \pi i$$

For the complete circle we may write as follows;

$$\oint_c \frac{1}{z} dz = -I_1 + I_2 = -(-\pi i) + (\pi i) = 2\pi i$$

**Example:**

Evaluate  $\int_c (z - z_0)^n dz$  where  $C$  is a circle centered at  $z_0$  having radius 'r' also check the result for  $n = -1$  as well as  $n \neq -1$  where 'n' is an integer.

**Solution:**

In case of circle  $|z - z_0| = r \Rightarrow z - z_0 = re^{i\theta} \Rightarrow z = z_0 + re^{i\theta} ; 0 \leq \theta \leq 2\pi$

$$\int_c (z - z_0)^n dz = \int_0^{2\pi} (re^{i\theta})^n (ire^{i\theta} d\theta) = \frac{r^{n+1}}{n+1} \left| e^{i(n+1)\theta} \right|_0^{2\pi}$$

**When  $n = -1$ :**

$$\int_0^{2\pi} (z - z_0)^{-1} dz = \int_0^{2\pi} (re^{i\theta})^{-1} (ire^{i\theta} d\theta) = 2\pi i$$

**When  $n \neq -1$ :**

$$\int_c (z - z_0)^n dz = \int_0^{2\pi} (z - z_0)^n dz = \frac{r^{n+1}}{n+1} \left| e^{i(n+1)\theta} \right|_0^{2\pi} = 0$$

Hence we can conclude that

$$\int_c (z - z_0)^n dz = \begin{cases} \frac{r^{n+1}}{n+1} \left| e^{i(n+1)\theta} \right|_0^{2\pi} & ; \text{for } n \in \mathbb{Z} \\ 2\pi i & ; \text{for } n = -1 \\ 0 & ; \text{for } n \neq -1 \end{cases}$$

**Exercise 33: (visit @ Youtube “learning with Usman Hamid”)**

- i. Prove that  $\int_{c_1} f(z) dz = \int_{c_2} f(z) dz$
- ii. Evaluate  $\int_0^{3+i} z^2 dz$  where C consists of OA, AB and OB.
- iii. Evaluate  $\int_{1-i}^{1+i} (z^2 + 1) dz$  where Curve is from (1, -1) to (1,1)
- iv. Evaluate  $\int_c \frac{dz}{z^2+1}$  where C is a circle  $|z + i| = 1$
- v. Evaluate  $\int_{-i}^i e^{3z} dz$  where Curve is from (0, -1) to (0,1)
- vi. Evaluate  $\int_c \frac{(x^2 - iy^3)}{7} dz$  where C is the lower half of the circle  $|z| = 1$  from  $z = -1$  to  $z = 1$
- vii. Find the value of the integral  $\int_c |z| dz$  when C is
  - a) Line from  $z = -1$  to  $z = 1$
  - b) The semi-circle  $|z| = 1$  from  $z = -1$  to  $z = 1$
  - c) The circle  $|z| = r$  with arbitrary initial and final points.
- viii. Find the value of the integral  $\int_c \frac{1}{z} dz$  when C is a semicircular arc  $|z| = 1$  from 1 to -1 according as the arc lies above or below the real axis.
- ix. Find the value of the integral  $\int_c \frac{dz}{z}$  when C is a square described in the positive sense with sides parallel to the axis and of length 2a and having its center at the origin.
- x. Evaluate  $\int_c |z| dz$  where C is a circle  $|z - 1| = 1$  described in the positive sense.
- xi. Find the value of the integral  $\int_0^{1+i} (x - y + ix^2) dz$ 
  - i. along the straight line  $z = 0$  to  $z = 1+i$
  - ii. along the imaginary axis from  $z = 0$  to  $z = i$
  - iii. along a line parallel to the real axis from  $z = i$  to  $z = 1+i$
- xii. Find all possible values of  $\int_c \frac{dz}{z^2+1}$  is a smooth curve with initial point '0' and final point is '1'. What restrictions must be imposed on?
- xiii. Evaluate  $\int_0^{1+i} (z - 1) dz$  on the curve  $y = x^2$
- xiv. Find the value of the integral  $\int_c f(z) dz$  where C consists of OABO with  $f(z) = y - x - i3x^2$

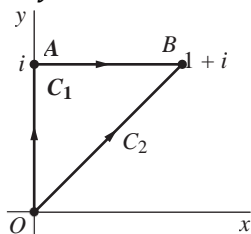

- xv. Find the value of the integral  $\int_C \bar{z} dz$  when  $C$  is the right hand half  $z = 2e^{i\theta}$  ;  $(-\frac{\pi}{2} \leq \theta \leq \frac{\pi}{2})$  of the circle  $|z| = 2$  from  $z = -2i$  to  $z = 2i$

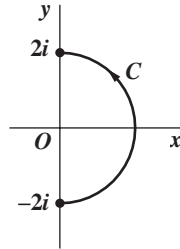

- xvi. Find the value of the integral  $\int_C \frac{1}{z^2-1} dz$  where  $C$  is a circle  $|z| = 2$
- xvii. Find  $\int_C \operatorname{Re}(z) dz$  where  $C$  denoted the unit circle described in the positive sense from  $z = 1$  to  $z = 1$
- xviii. Evaluate  $\int_C f(z) dz$  with  $f(z) = \frac{z+2}{z}$  with the curve
- the semicircle  $z = 2e^{i\theta}$  ( $0 \leq \theta \leq \pi$ );
  - the semicircle  $z = 2e^{i\theta}$  ( $\pi \leq \theta \leq 2\pi$ );
  - the circle  $z = 2e^{i\theta}$  ( $0 \leq \theta \leq 2\pi$ ).
- xix. Evaluate  $\int_C f(z) dz$  with  $f(z) = z - 1$  with  $C$  is the arc from  $z = 0$  to  $z = 2$  consisting of
- the semicircle  $z = 1 + e^{i\theta}$  ( $\pi \leq \theta \leq 2\pi$ );
  - the segment  $z = x$  ( $0 \leq x \leq 2$ ) of the real axis.
- xx. Evaluate  $\int_C f(z) dz$  with  $f(z) = \pi \exp(\pi \bar{z})$  and  $C$  is the boundary of the square with vertices at the points  $0, 1, 1 + i, i$ , the orientation of  $C$  being in the counterclockwise direction.
- xxi. Evaluate  $\int_C f(z) dz$  where  $f(z)$  is defined by means of the equations  $f(z) = \begin{cases} 1 & \text{when } y < 0 \\ 4 & \text{when } y > 0 \end{cases}$  and  $C$  is the arc from  $z = -1 - i$  to  $z = 1 + i$  along the curve  $y = x^3$ .
- xxii. Let  $C_0$  denote the circle centered at  $z_0$  with radius  $R$  and use the parameterization  $z = z_0 + Re^{i\theta}$  ;  $-\pi \leq \theta \leq \pi$  to show that
- $$\int_{C_0} (z - z_0)^{n-1} dz = \begin{cases} 0 & ; n = \pm 1, \pm 2, \dots \dots \\ 2\pi i & ; n = 0 \end{cases}$$
- xxiii. Evaluate  $\int_C f(z) dz$  with  $f(z) = 1$  and  $C$  is an arbitrary contour from any fixed point  $z_1$  to any fixed point  $z_2$  in the  $z$  plane.
- xxiv. Evaluate  $\int_C \bar{z} dz$  where  $z = t^2 + it$  and  $C$  is from  $z = 0$  to  $z = 4 + 2i$  along
- Line from  $z = 0$  to  $z = 2i$
  - Line from  $z = 2i$  to  $z = 4 + 2i$

## UPPER BOUNDS FOR MODULI OF CONTOUR INTEGRALS

We turn now to an inequality involving contour integrals that is extremely important in various applications.

**Lemma:** If  $w(t)$  is a piecewise continuous complex-valued function defined on an interval  $a \leq t \leq b$ , then  $\left| \int_a^b w(t) dt \right| \leq \int_a^b |w(t)| dt$

**Proof:** Consider  $\int_a^b w(t) dt = r_0 e^{i\theta_0} \Rightarrow \left| \int_a^b w(t) dt \right| = r_0$

Now from  $\int_a^b w(t) dt = r_0 e^{i\theta_0} \Rightarrow r_0 = \int_a^b e^{-i\theta_0} w(t) dt$

Now the left-hand side of this equation is a real number, and so the right-hand side is too. Thus, using the fact that the real part of a real number is the number itself, we find that

$$r_0 = \operatorname{Re} \int_a^b e^{-i\theta_0} w(t) dt \Rightarrow r_0 = \int_a^b \operatorname{Re} [e^{-i\theta_0} w(t)] dt$$

$$\text{But } \operatorname{Re} [e^{-i\theta_0} w(t)] \leq |e^{-i\theta_0} w(t)| = |e^{-i\theta_0}| |w(t)| = |w(t)|$$

$$\Rightarrow r_0 = \int_a^b \operatorname{Re} [e^{-i\theta_0} w(t)] dt \leq \int_a^b |w(t)| dt$$

$$\text{Hence } \left| \int_a^b w(t) dt \right| \leq \int_a^b |w(t)| dt$$

**A Bounding Theorem: (ML inequality)** Let  $C$  denote a contour of length  $L$ , and suppose that a function  $f(z)$  is piecewise continuous on  $C$ . If  $M$  is a nonnegative constant such that  $|f(z)| \leq M$  for all points  $z$  on  $C$  at which  $f(z)$  is defined, then  $\left| \int_C f(z) dz \right| \leq ML$ .

**Proof:**

$$\text{we know that } \int_C f(z) dz = \lim_{n \rightarrow \infty} \sum_{k=1}^n f(z_k) \Delta z_k = \sum_{k=1}^n f(z_k) \Delta z_k$$

$$\Rightarrow \left| \int_C f(z) dz \right| = \left| \sum_{k=1}^n f(z_k) \Delta z_k \right| \leq \sum_{k=1}^n |f(z_k)| |\Delta z_k|$$

$$\Rightarrow \left| \int_C f(z) dz \right| \leq |f(z_k)| \sum_{k=1}^n |\Delta z_k| = M \int_C ds = ML$$

$$\Rightarrow \left| \int_C f(z) dz \right| \leq ML \quad \text{as required.}$$

**Remarks:**

- i.  $|dz| = d|z|$
- ii.  $|dz| = ds$
- iii.  $L = \int_C ds = \int_C |dz|$
- iv.  $\left| \int_C f(z) dz \right| \leq \int_C |f(z)| |dz|$
- v.  $M = |f(z)|$



**Example :** Let  $C$  be the arc of the circle  $|z| = 2$  from  $z=2$  to  $z=2i$  that lies in the first quadrant (Fig). Then show that  $\left| \int_C \frac{z-2}{z^4+1} dz \right| \leq \frac{4\pi}{15}$

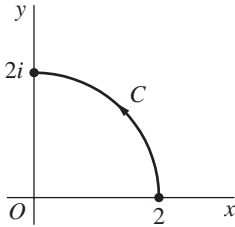

**Solution:** This is done by noting first that if  $z$  is a point on  $C$ , then

$$|z - 2| = |z + (-2)| \leq |z| + |-2| = 2 + 2 = 4$$

$$\text{And } |z^4 + 1| \geq ||z^4| - 1| = 15 \Rightarrow \frac{1}{|z^4+1|} \leq \frac{1}{15}$$

$$\text{Thus when } C \text{ lies on } C, \quad M = |f(z)| = \left| \frac{z-2}{z^4+1} \right| = \frac{|z-2|}{|z^4+1|} \leq \frac{4}{15}$$

Now since  $z = z(t) \Rightarrow dz = z'(t)dt$  also  $z = re^{i\theta} = |z|e^{i\theta}$

$$\text{Then } z = 2e^{i\theta} \Rightarrow |dz| = |2ie^{i\theta}d\theta| = 2d\theta$$

$$\Rightarrow L = \int_C ds = \int_C |dz| = 2 \int_0^{\frac{\pi}{2}} d\theta = \pi \quad \text{and using } M = \frac{4}{15}$$

Then according to ML inequality  $\left| \int_C f(z) dz \right| \leq ML$

$$\Rightarrow \left| \int_C \frac{z-2}{z^4+1} dz \right| \leq \frac{4\pi}{15}$$

**Example :** Prove that  $\left| \int_i^{2+i} \frac{1}{z^2} dz \right| \leq 2$

**Solution:** consider a smooth curve AB from A(0,1) and B(2,1) in which  $y = 1$ ,  $x = t$  and  $0 \leq t \leq 2$

$$\text{Now } |z^2| = x^2 + y^2 \Rightarrow |z^2| \geq y^2$$

$$\text{For } y = 1, x = t \text{ and } 0 \leq t \leq 2 \Rightarrow |z^2| \geq 1 \Rightarrow 1 \geq \frac{1}{|z^2|} \Rightarrow \frac{1}{|z^2|} \leq 1$$

Hence

$$\text{Thus when } C \text{ lies on } C, \quad M = |f(z)| = \left| \frac{1}{z^2} \right| \leq 1$$

Now For  $y = 1, x = t$  and  $0 \leq t \leq 2$

$$\Rightarrow L = \int_C ds = \int_C |dz| = \int_C |dx + dy| = \int_C |dt + 0| = \int_C dt = \int_0^2 dt = 2$$

Then according to ML inequality  $\left| \int_C f(z) dz \right| \leq ML$

$$\Rightarrow \left| \int_i^{2+i} \frac{1}{z^2} dz \right| \leq 2$$

**Example :** Evaluate  $\left| \int_C \bar{z} dz \right|$  where  $C$  is a semi unit circle.

**Solution:** for semi unit circle  $r=1$   $x = \cos\theta, y = \sin\theta$  and  $0 \leq \theta \leq \pi$

Now  $|\bar{z}| = |\overline{x+iy}| = |x^2 + y^2| = |r^2| = 1$

Hence  $M = |f(z)| = |\bar{z}| \leq 1$

Now For  $x = \cos\theta \Rightarrow dx = -\sin\theta, y = \sin\theta \Rightarrow dy = \cos\theta$  and  $0 \leq \theta \leq \pi$

$\Rightarrow L = \int_C ds = \int_C |dz| = \int_C |dx + idy| = \int_C d\theta = \int_0^\pi d\theta = \pi$

Then according to ML inequality  $\left| \int_C f(z) dz \right| \leq ML$

$\Rightarrow \left| \int_C \bar{z} dz \right| \leq \pi$

**Exercises 34: (visit @ Youtube “learning with Usman Hamid”)**

- Find an upper bound for  $\left| \frac{-1}{z^4-5z+1} \right|$  if  $|z| = 2$
- Find an upper bound for  $\left| \frac{-1}{z^4-5z+1} \right|$  if  $|z| = 1$
- Find an upper bound for the modulus of  $3z^2 + 2z + 1$  if  $|z| \leq 1$
- Find an upper bound for the absolute value of  $\oint_C \frac{5z+7}{z^2+2z-3} dz$  where  $C$  is circle  $|z-2| = 2$
- Without evaluating the integral for arc of the circle  $|z| = 2$  from  $z=2$  to  $z=2i$ , show that
  - $\left| \int_C \frac{z+4}{z^3-1} dz \right| \leq \frac{6\pi}{7}$
  - $\left| \int_C \frac{1}{z^2-1} dz \right| \leq \frac{\pi}{3}$
- Prove that  $\left| \int_C (x^2 + iy^2) dz \right| \leq \pi$  where  $C$  is a semi-circle  $z = \pm i$  as ends of the diameter.
- Without evaluating the integral for  $C$  as the line segment from  $z = i$  to  $z=1$ , show that  $\left| \int_C \frac{1}{z^4} dz \right| \leq 4\sqrt{2}$
- Show that if  $C$  is the boundary of the triangle with vertices at the points  $0, 3i$ , and  $-4$  oriented in the counterclockwise direction (see Fig), then  $\left| \int_C (e^z - \bar{z}) dz \right| \leq 60$

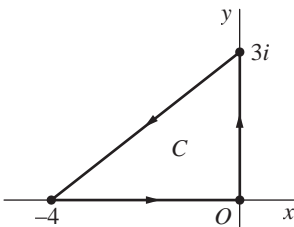

- Find an upper bound for  $\oint_C \frac{e^z}{z+1} dz$  where  $C$  is the circle  $|z| = 4$

**Example:** Let  $C_R$  is the semicircular path  $z = Re^{i\theta}$  ( $0 \leq \theta \leq \pi$ ),  
From  $z = R$  to  $z = -R$  where  $R > 3$  then show that

$$\lim_{R \rightarrow \infty} \int_{C_R} \frac{z+1}{(z^2+4)(z^2+9)} dz = 0$$

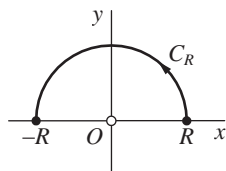

**Solution:** We observe that if  $z$  is a point on  $C_R$  then

$$|z + 1| \leq |z| + |1| = |z| + 1 = R + 1$$

$$\text{And } |z^2 + 4| \geq ||z^2| - 4| = R^2 - 4 \Rightarrow \frac{1}{|z^2+4|} \leq R^2 - 4$$

$$\text{Also } |z^2 + 9| \geq ||z^2| - 9| = R^2 - 9 \Rightarrow \frac{1}{|z^2+9|} \leq R^2 - 9$$

Thus when 'z' lies on  $C_R$ ,

$$M = |f(z)| = \left| \frac{z+1}{(z^2+4)(z^2+9)} \right| = \frac{|z+1|}{|z^2+4||z^2+9|} \leq \frac{R+1}{(R^2-4)(R^2-9)}$$

$$\Rightarrow L = \int_C ds = \int_C |dz| = R \int_0^\pi d\theta = \pi R$$

$$\text{and using } M = M_R = \frac{R+1}{(R^2-4)(R^2-9)}$$

Then according to ML inequality  $\left| \int_C f(z) dz \right| \leq ML$

$$\Rightarrow \left| \int_{C_R} \frac{z+1}{(z^2+4)(z^2+9)} dz \right| \leq \frac{R+1}{(R^2-4)(R^2-9)} \cdot \pi R$$

$$\Rightarrow \left| \int_{C_R} \frac{z+1}{(z^2+4)(z^2+9)} dz \right| \leq \frac{\pi(R^2+R)}{(R^2-4)(R^2-9)} \frac{1}{R^4} = \frac{\pi\left(\frac{1}{R^2} + \frac{1}{R^3}\right)}{\left(1 - \frac{4}{R^2}\right)\left(1 - \frac{9}{R^2}\right)}$$

$$\Rightarrow \lim_{R \rightarrow \infty} \left| \int_{C_R} \frac{(z+1)dz}{(z^2+4)(z^2+9)} \right| = \left| \lim_{R \rightarrow \infty} \int_{C_R} \frac{z+1}{(z^2+4)(z^2+9)} dz \right| \leq \lim_{R \rightarrow \infty} \frac{\pi\left(\frac{1}{R^2} + \frac{1}{R^3}\right)}{\left(1 - \frac{4}{R^2}\right)\left(1 - \frac{9}{R^2}\right)} = 0$$

$$\Rightarrow \lim_{R \rightarrow \infty} \int_{C_R} \frac{z+1}{(z^2+4)(z^2+9)} dz = 0$$

**Exercises 35: (visit @ Youtube “learning with Usman Hamid”)**

i. Let  $C_R$  is the upper half of the circle  $|z| = R$  ( $R > 2$ ) taken in counterclockwise direction then show that

$$\left| \int_{C_R} \frac{2z^2-1}{z^4+5z^2+4} dz \right| \leq \frac{\pi R(2R^2+1)}{(R^2-1)(R^2-4)}$$

Also show that  $\lim_{R \rightarrow \infty} \int_{C_R} \frac{2z^2-1}{z^4+5z^2+4} dz = 0$

ii. Let  $C_R$  is the circle  $|z| = R$  ( $R > 1$ ) taken in counterclockwise direction then show that

$$\left| \int_{C_R} \frac{\log z}{z^2} dz \right| \leq 2\pi \left( \frac{\pi + \ln R}{R} \right)$$

Also show that  $\lim_{R \rightarrow \infty} \int_{C_R} \frac{\log z}{z^2} dz = 0$

iii. Let  $C_\rho$  is the circle  $|z| = \rho$  ( $0 < \rho < 1$ ) taken in counterclockwise direction and supposed that  $f(z)$  is analytic in the disk  $|z| \leq 1$  then show that

$$\left| \int_{C_\rho} z^{-1/2} f(z) dz \right| \leq 2\pi M \sqrt{\rho}$$

Also show that  $\lim_{\rho \rightarrow 0} \int_{C_\rho} z^{-1/2} f(z) dz = 0$

## ANTIDERIVATIVES

Our next theorem is useful in determining when integration is independent of path and, moreover, when an integral around a closed path has value zero.

The theorem contains an extension of the fundamental theorem of calculus that simplifies the evaluation of many contour integrals. The extension involves the concept on an antiderivative of a continuous function  $f(z)$  on a domain  $D$ , or a function  $F(z)$  such that  $F'(z) = f(z)$  for all  $z$  in  $D$ .

Note that an antiderivative is, of necessity, an analytic function.

## INDEFINITE INTEGRAL OR ANTIDERIVATIVE OR PRIMITIVE

Let  $f(z)$  be a single valued analytic function on a domain  $D$ , then a function  $F(z)$  is said to be an indefinite integral or antiderivative or primitive of  $f(z)$  if  $F(z)$  is analytic on  $D$  and  $F'(z) = f(z)$  for all  $z$  in  $D$

Note: if  $F'(z) = f(z)$  then  $F(z) = \int f(z)dz + c$

## FUNDAMENTAL THEOREM OF INTEGRAL CALCULUS FOR COMPLEX NUMBERS

Suppose that a function  $f(z)$  is an analytic function in a simply connected domain  $D$ , if  $z_1, z_2 \in R$  then

$$\int_{z_1}^{z_2} f(z)dz = |F(z)|_{z_1}^{z_2} = F(z_2) - F(z_1)$$

where  $F(z)$  is the antiderivative of  $f(z)$

### Proof:

$$\text{Let } \varphi(z) = \int_{z_1}^z f(z)dz \dots\dots\dots(i)$$

$$\Rightarrow \varphi(z = z_1) = \int_{z_1}^{z_1} f(z)dz = 0 \dots\dots\dots(ii)$$

$$\text{And } \Rightarrow \varphi(z = z_2) = \int_{z_1}^{z_2} f(z)dz \dots\dots\dots(iii)$$

Subtracting (ii) from (iii)

$$\Rightarrow \varphi(z_2) - \varphi(z_1) = \int_{z_1}^{z_2} f(z)dz \dots\dots\dots(iv)$$

Now by definition of antiderivative  $F(z) = \varphi(z) + c$

$$\Rightarrow F(z_1) = \varphi(z_1) + c \text{ and } F(z_2) = \varphi(z_2) + c$$

$$\Rightarrow F(z_1) - F(z_2) = \varphi(z_1) + c - \varphi(z_2) - c = \varphi(z_1) - \varphi(z_2)$$

Hence

$$(iv) \Rightarrow \int_{z_1}^{z_2} f(z)dz = |F(z)|_{z_1}^{z_2} = F(z_2) - F(z_1)$$

**Example:** The continuous function  $f(z) = e^{\pi z}$  evidently has an antiderivative  $F(z) = \frac{e^{\pi z}}{\pi}$  throughout the finite plane.

Hence

$$\int_i^{i/2} e^{\pi z} dz = \left| \frac{e^{\pi z}}{\pi} \right|_i^{i/2} = \frac{1}{\pi} (e^{i\pi/2} - e^{i\pi}) = \frac{1}{\pi} (i + 1) = \frac{1}{\pi} (1 + i)$$

**Example:**

Show that for the function  $f(z) = \frac{1}{z^2}$  which is continuous everywhere except at the origin  $\int_C \frac{1}{z^2} dz = 0$  where C is a unit circle  $|z| = 1$

OR show that  $\int_C \frac{1}{z^2} dz = 0$  where C is a unit circle  $|z| = 1$

**Solution:**

Given that curve is unit circle i.e.  $|z| = 1$

Then  $z = e^{i\theta} \Rightarrow dz = ie^{i\theta} d\theta$  also  $0 \leq \theta \leq 2\pi$

Then  $\int_C \frac{1}{z^2} dz = \int_0^{2\pi} \frac{1}{z^2} dz = \int_0^{2\pi} \frac{ie^{i\theta} d\theta}{e^{2i\theta}} = i \int_0^{2\pi} e^{-i\theta} d\theta = i \left| \frac{e^{-i\theta}}{-i} \right|_0^{2\pi}$

$\int_C \frac{1}{z^2} dz = i \left| \frac{e^{-i\theta}}{-i} \right|_0^{2\pi} = -|e^{-i\theta}|_0^{2\pi} = -(e^{-2\pi} - e^0) = e^0 - e^{-2\pi} = 1 - 1 = 0$

Hence  $\int_C \frac{1}{z^2} dz = 0$

**Example:** If  $f(z) = \frac{1}{z}$  then  $\int_C f(z) dz = 2\pi i$  for  $|z| = 1$

**Solution:**

Given that curve is unit circle i.e.  $|z| = 1$

Then  $z = e^{i\theta} \Rightarrow dz = ie^{i\theta} d\theta$  also  $0 \leq \theta \leq 2\pi$

Then  $\int_C \frac{1}{z} dz = \int_0^{2\pi} \frac{1}{z} dz = \int_0^{2\pi} \frac{ie^{i\theta} d\theta}{e^{i\theta}} = i \int_0^{2\pi} d\theta = i|\theta|_0^{2\pi}$

Hence  $\int_C f(z) dz = 2\pi i$

**Exercise 36: (visit @ Youtube “learning with Usman Hamid”)**

- Use antiderivatives to show that for every contour C extending from a point  $z_1$  to a point  $z_2$  it should be  $\int_C z^n dz = \frac{1}{n+1} (z_2^{n+1} - z_1^{n+1})$
- By finding antiderivative evaluate each of the following;
  - $\int_0^{1+i} z^2 dz$
  - $\int_0^{\pi+2i} \cos\left(\frac{z}{2}\right) dz$
  - $\int_1^3 (z-2)^3 dz$
- Show that  $\int_{C_0} (z-z_0)^{n-1} dz = 0$  where  $C_0$  is any closed contour which does not pass through the point  $z_0$ .
- Evaluate the integral  $\int_C \frac{1}{(z-a)^n} dz$  where C is closed contour enclosing the point  $z = a$  interpret the result when  $n = 1, 2, 3, \dots$

**GREEN'S THEOREM (weaker version of Cauchy Fundamental theorem)**

If C is a curve enclosing the area S then

$$\int_C Mdx + Ndy = \iint_S \left( \frac{\partial N}{\partial x} - \frac{\partial M}{\partial y} \right) dxdy$$

where  $M = M(x, y)$  and  $N = N(x, y)$  are functions of 'x' and 'y' and have continuous first order partial derivatives.

**Proof:**

Consider a closed curve enclosed by the surface S.

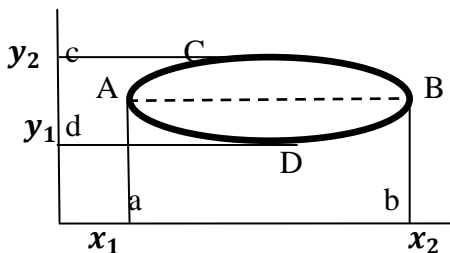

Consider

$$\iint_S \frac{\partial M}{\partial y} dxdy = \int_a^b \left( \int_{y_1}^{y_2} \frac{\partial M}{\partial y} dy \right) dx = \int_a^b [M(x, y)]_{y_1}^{y_2} dx$$

$$\iint_S \frac{\partial M}{\partial y} dxdy = \int_a^b [M(x, y_2) - M(x, y_1)] dx$$

$$\iint_S \frac{\partial M}{\partial y} dxdy = \int_a^b M(x, y_2) dx - \int_a^b M(x, y_1) dx$$

$$\iint_S \frac{\partial M}{\partial y} dxdy = \int_{ACB} M(x, y) dx - \int_{ADB} M(x, y) dx$$

$$\iint_S \frac{\partial M}{\partial y} dxdy = -\int_{BCA} M(x, y) dx - \int_{ADB} M(x, y) dx = -\int_{BCADB} M(x, y) dx$$

$$\int_C M(x, y) dx = -\iint_S \frac{\partial M}{\partial y} dxdy \quad \dots\dots\dots(A)$$

Now consider

$$\iint_S \frac{\partial N}{\partial x} dxdy = \int_a^c \left( \int_{x_1}^{x_2} \frac{\partial N}{\partial x} dx \right) dy = \int_a^c [N(x, y)]_{x_1}^{x_2} dy$$

$$\iint_S \frac{\partial N}{\partial x} dxdy = \int_a^c [N(x_2, y) - N(x_1, y)] dy$$

$$\iint_S \frac{\partial N}{\partial x} dxdy = \int_a^c N(x_2, y) dy - \int_a^c N(x_1, y) dy$$

$$\iint_S \frac{\partial N}{\partial x} dxdy = \int_{DAC} N(x, y) dy - \int_{DBC} N(x, y) dy$$

$$\iint_S \frac{\partial N}{\partial x} dxdy = \int_{DAC} N(x, y) dy + \int_{CBD} N(x, y) dy = \int_{DACBD} N(x, y) dy$$

$$\int_C N(x, y) dy = \iint_S \frac{\partial N}{\partial x} dxdy \quad \dots\dots\dots(B)$$

Adding (A) and (B)

$$\int_C M(x, y) dx + \int_C N(x, y) dy = -\iint_S \frac{\partial M}{\partial y} dxdy + \iint_S \frac{\partial N}{\partial x} dxdy$$

Hence  $\int_C Mdx + Ndy = \iint_S \left( \frac{\partial N}{\partial x} - \frac{\partial M}{\partial y} \right) dxdy$

### SIMPLY CONNECTED DOMAINS/ REGIONS

A *simply connected* domain  $D$  is a domain such that every simple closed contour within it encloses only points of  $D$ . The set of points interior to a simple closed contour is an example. The annular domain between two concentric circles is, however, not simply connected.

**OR** A region in which every closed curve can be shrunk to a point without passing out of the region.

### CAUCHY FUNDAMENTAL THEOREM

Let  $D$  be a simply connected region and  $f(z)$  be a single valued continuously differentiable function on  $D$  then  $\int_C f(z)dz = 0$  where  $C$  is any closed contour contained in  $D$ .

**OR** . If a function  $f$  is analytic and continuous at all points interior to and on a simple closed contour  $C$ , then  $\int_C f(z)dz = 0$

**Proof:** Let  $\int_C f(z)dz = \int_C (u + iv)(dx + idy)$

$$\int_C f(z)dz = \int_C udx - vdy + i \int_C udy + vdx \dots\dots\dots(i)$$

By using Green's theorem

$$\int_C udx - vdy = \iint_R (-v_x - u_y) dx dy \dots\dots\dots(ii)$$

$$\text{Also } \int_C udy + vdx = \iint_R (u_x - v_y) dx dy \dots\dots\dots(iii)$$

Using (ii) and (iii) in (i)

$$\int_C f(z)dz = \iint_R (-v_x - u_y) dx dy + i \iint_R (u_x - v_y) dx dy$$

CR equations hold for given function being Analytic then  $u_x = v_y, u_y = -v_x$

$$\int_C f(z)dz = \iint_R (u_y - u_y) dx dy + i \iint_R (v_y - v_y) dx dy$$

$$\int_C f(z)dz = 0 \quad \text{as required.}$$

### REMARK:

- The conditions stated in CFT are only sufficient but not necessary.
- CFT is more useful in Applied Mathematics because the continuity of four partial derivatives  $u_x, u_y, v_x, v_y$  is generally assumed on physical ground.
- **Goursat (E. Goursat (1858- 1936), pronounced gour – sah.)** was the first to prove that the condition of continuity on  $f'$  can be omitted. Its removal is important and will allow us to show, for example, that the derivative  $f'$  of an analytic function  $f$  is analytic without having to assume the continuity of  $f'$ , which follows as a consequence. Statement is as follows;

**Cauchy Goursat Theorem.** *If a function  $f$  is analytic at all points interior to and on a simple closed contour  $C$ , then  $\int_C f(z)dz = 0$ .*



**Example:** If  $C$  denotes any closed contour lying in the open disk  $|z| < 2$  then evaluate  $\int_c \frac{\text{Sin}z}{(z^2+9)^2} dz$

**Solution:** Since the disk is a simply connected domain and the two singularities  $z = \pm 3i$  of the integrand are exterior to the disk. So given function is non – analytic on these. Then by Cauchy Fundamental Theorem

$$\int_c \frac{\text{Sin}z}{(z^2+9)^2} dz = 0$$

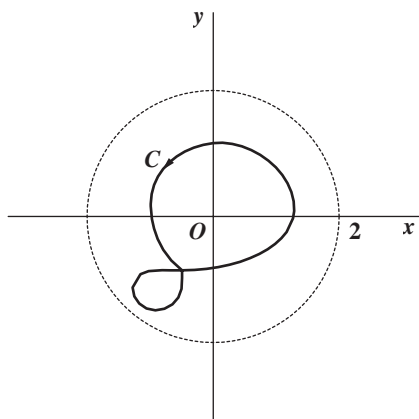

**Example:** If  $C$  is a unit circle then evaluate  $\int_c \frac{\text{Sin}hz+e^z+z}{(z^2-4)(z^2+9)} dz$

**Solution:** Since the four singularities  $z = \pm 2, \pm 3i$  of the integrand are exterior to the disk. So given function is non – analytic on these. Then by Cauchy Fundamental Theorem

$$\int_c \frac{\text{Sin}hz+e^z+z}{(z^2-4)(z^2+9)} dz = 0$$

**Example:** If  $C$  is a curve such that  $|z| = 2$  then evaluate  $\int_c \frac{\text{Cosh}z+e^z}{(z+5)(z+3)} dz$

**Solution:** Since the two singularities  $z = -5, -3$  of the integrand are exterior to the disk. So given function is non – analytic on these. Then by Cauchy

Fundamental Theorem  $\int_c \frac{\text{Cosh}z+e^z}{(z+5)(z+3)} dz = 0$

**Exercise 37: (visit @ Youtube “learning with Usman Hamid”)**

1. show that if  $C$  is positively oriented simple closed contour, then the area of region enclosed by  $C$  can be written as  $\frac{1}{2i} \int_c \bar{z} dz$
2. Evaluate  $\oint_C \frac{dz}{z^2}$  where  $C$  is the ellipse  $(x - 2)^2 + \frac{1}{4}(y - 5)^2 = 1$
3. Show that  $\int_c f(z) dz = 0$  when the contour  $C$  is the unit circle  $|z| = 1$  in either direction with the following functions;
 

i. $f(z) = \frac{z^2}{z+3}$	iv. $f(z) = \text{Sech}z$
ii. $f(z) = ze^{-z}$	v. $f(z) = \text{Tanz}$
iii. $f(z) = \frac{1}{z^2+2z+1}$	vi. $f(z) = \log(z+2)$

**Corollary:** A function  $f$  that is analytic throughout a simply connected domain  $D$  must have an antiderivative everywhere in  $D$ .

**Corollary:** Entire function always possesses antiderivatives.

### MULTIPLY CONNECTED DOMAINS

A domain that is not simply connected is said to be *multiply connected*.

**OR** A domain or region in which every closed curve cannot be shrunk to a point without passing out of the region.

### CONSEQUENCES OF CAUCHY FUNDAMENTAL THEOREM

**Corollary:** Let  $C_1$  and  $C_2$  denote positively oriented simple closed contours, where  $C_1$  is interior to  $C_2$  (Fig). If a function  $f$  is analytic in the closed region consisting of those contours and all points between them, then

$$\int_{C_1} f(z) dz = \int_{C_2} f(z) dz$$

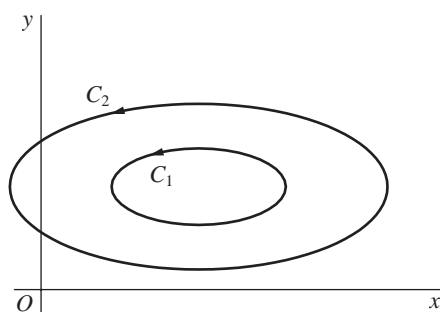

This corollary is known as the *principle of deformation of paths* since it tells us that if  $C_1$  is continuously deformed into  $C_2$ , always passing through points at which  $f$  is analytic, then the value of the integral of  $f$  over  $C_1$  never changes.

**Corollary:** Let  $C_1$  and  $C_2$  denote positively oriented simple closed contours. If a function  $f$  is analytic in the closed region consisting of those contours and all points between them, then  $\int_a^b f(z) dz$  will be independent of path from all these points.

### CAUCHY INTEGRAL FORMULA

Let  $f$  be analytic everywhere inside and on a simple closed contour  $C$ , taken in the positive sense. If  $z_0$  is any point interior to  $C$ , then

$$f(z_0) = \frac{1}{2\pi i} \int_C \frac{f(z)}{z-z_0} dz \quad \text{OR} \quad \int_C \frac{f(z)}{z-z_0} dz = 2\pi i f(z_0)$$

**Proof:**

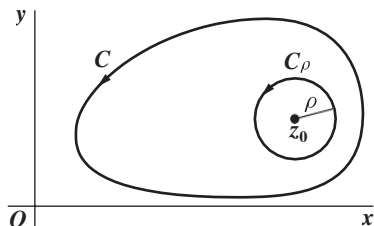

Let  $C_\rho$  denote a positively oriented circle  $|z - z_0| = \rho$ , where  $\rho$  is small enough that  $C_\rho$  is interior to  $C$  (see Fig). Since the quotient  $\frac{f(z)}{z-z_0}$  is analytic between and on the contours  $C_\rho$  and  $C$  but not on  $z_0$ , it follows from the principle of deformation of paths that

$$\begin{aligned} \int_C \frac{f(z)}{z-z_0} dz &= \int_{C_\rho} \frac{f(z)}{z-z_0} dz \\ \int_C \frac{f(z)}{z-z_0} dz &= \int_{C_\rho} \frac{f(z)-f(z_0)+f(z_0)}{z-z_0} dz = \int_{C_\rho} \frac{f(z)-f(z_0)}{z-z_0} dz + \int_{C_\rho} \frac{f(z_0)}{z-z_0} dz \\ \int_C \frac{f(z)}{z-z_0} dz &= \int_{C_\rho} \frac{f(z)-f(z_0)}{z-z_0} dz + f(z_0) \int_{C_\rho} \frac{1}{z-z_0} dz \\ \int_C \frac{f(z)}{z-z_0} dz &= I_1 + f(z_0) I_2 \quad \dots\dots\dots(i) \end{aligned}$$

$$\begin{aligned} \text{Now } I_1 &= \int_{C_\rho} \frac{f(z)-f(z_0)}{z-z_0} dz \Rightarrow |I_1| = \left| \int_{C_\rho} \frac{f(z)-f(z_0)}{z-z_0} dz \right| \leq \int_{C_\rho} \left| \frac{f(z)-f(z_0)}{z-z_0} \right| |dz| \\ \Rightarrow |I_1| &= |f(z) - f(z_0)| \left| \frac{1}{z-z_0} \right| \int_{C_\rho} |dz| < \frac{\rho}{\rho} \int_0^{2\pi} \rho d\theta = 2\pi\rho \\ \Rightarrow I_1 &< 2\pi\rho \rightarrow 0 \text{ as } \rho \rightarrow 0 \text{ with } |z - z_0| = \rho \Rightarrow z - z_0 = \rho e^{i\theta} \end{aligned}$$

$$\text{Now } I_2 = \int_{C_\rho} \frac{1}{z-z_0} dz = \int_0^{2\pi} \frac{i\rho e^{i\theta}}{\rho e^{i\theta}} d\theta = 2\pi i$$

$$\Rightarrow \int_C \frac{f(z)}{z-z_0} dz = 0 + f(z_0) \cdot 2\pi i$$

$$\text{Hence} \quad f(z_0) = \frac{1}{2\pi i} \int_C \frac{f(z)}{z-z_0} dz \quad \text{OR} \quad \int_C \frac{f(z)}{z-z_0} dz = 2\pi i f(z_0)$$

This formula tells us that if a function  $f$  is to be analytic within and on a simple closed contour  $C$ , then the values of  $f$  interior to  $C$  are completely determined by the values of  $f$  on  $C$ . It can be used to evaluate certain integrals along simple closed contours.

**Remark:**

If in the quotient  $\frac{f(z)}{g(z)}$  the polynomial  $g(z)$  is linear of the form  $z - z_0$  and the contour contains the point  $z = z_0$  then we shall apply Cauchy Integral Formula and if  $g(z)$  is not linear we shall split it into partial fraction to get linear factors.

**Example:** Evaluate the integral  $\int_C \frac{\text{Cos}z}{z(z^2+9)} dz$  where  $C$  be the positively oriented circle  $|z|= 1$  about the origin.

**Solution:**

Since for the function  $g(z) = \frac{\text{Cos}z}{z(z^2+9)} = \frac{\frac{\text{Cos}z}{(z^2+9)}}{z} = \frac{f(z)}{z}$  point  $z = 0$  lies inside the circle  $|z|= 1$  and is Singular points, also  $f(z)$  is analytic inside and on  $C$  so by using Cauchy Integral Formula

$$\int_C \frac{f(z)}{z-z_0} dz = 2\pi i f(z_0)$$

$$\Rightarrow \int_C \frac{\text{Cos}z}{z(z^2+9)} dz = \int_C \frac{\frac{\text{Cos}z}{(z^2+9)}}{z-0} dz = 2\pi i f(0) = \frac{2\pi i}{9}$$

**Example:** Evaluate the integral  $\int_C \frac{\text{Cos}2z+\text{Cosh}2z}{z} dz$  where  $C: |z| = 1$

**Solution:**

Since for the function  $g(z) = \frac{\text{Cos}2z+\text{Cosh}2z}{z} = \frac{f(z)}{z}$  point  $z = 0$  lies inside the circle  $|z|= 1$  and is Singular points so by using Cauchy Integral Formula

$$\int_C \frac{f(z)}{z-z_0} dz = 2\pi i f(z_0)$$

$$\Rightarrow \int_C \frac{\text{Cos}2z+\text{Cosh}2z}{z} dz = 2\pi i f(0) = 4\pi i$$

**Example:** Evaluate the integral  $\int_C \frac{9z^2-iz+4}{z(z^2+1)} dz$  where  $C$  is a circle  $|z|= 2$

**Solution:**

Since for the function  $g(z) = \frac{9z^2-iz+4}{z(z^2+1)}$  points  $z = 0, \pm i$  lies inside the circle  $|z|= 2$  and are Singularities so by using Cauchy Integral Formula

$$\int_C \frac{f(z)}{z-z_0} dz = 2\pi i f(z_0) \dots\dots\dots(i)$$

Now by using partial fraction

$$\frac{9z^2-iz+4}{z(z^2+1)} = \frac{A}{z} + \frac{B}{(z+i)} + \frac{C}{(z-i)} = \frac{4}{z} + \frac{3}{(z+i)} + \frac{2}{(z-i)} \quad \text{after solving}$$

$$(i) \Rightarrow \int_C \frac{9z^2-iz+4}{z(z^2+1)} dz = \int_C \frac{4}{z} dz + \int_C \frac{3}{(z+i)} dz + \int_C \frac{2}{(z-i)} dz$$

$$\Rightarrow \int_C \frac{9z^2-iz+4}{z(z^2+1)} dz = 4[2\pi i f(0)] + 3[2\pi i f(-i)] + 2[2\pi i f(i)] = 18\pi i$$

**Exercise 38: (visit @ Youtube “learning with Usman Hamid”)**

1. Evaluate  $\int_C \frac{dz}{1+z^2}$  where  $C$  is the part of the parabola  $y = 4 - x^2$  from  $A(2,0)$  to  $B(-2,0)$
2. Evaluate  $\int_C \frac{dz}{z^2+2z+2}$  where  $C$  is the square having corners  $(0,0)$ ,  $(-2,0)$ ,  $(-2,-2)$ ,  $(0,-2)$
3. Let  $C$  denote the positively oriented boundary of the square whose sides lie along the lines  $x = \pm 2$  and  $y = \pm 2$ . Evaluate each of these integrals:

$$\begin{array}{ll} \text{a) } \int_C \frac{e^{-z}}{z - \left(\frac{\pi i}{2}\right)} dz & \text{c) } \int_C \frac{z}{2z+1} dz \\ \text{b) } \int_C \frac{\cos z}{z(z^2+8)} dz & \text{d) } \int_C \frac{\cosh z}{z^4} dz \\ \text{e) } \int_C \frac{\tan\left(\frac{z}{2}\right)}{(z-x_0)^2} dz; -2 < x_0 < 2 \end{array}$$

4. Find the value of the integral of  $g(z)$  around the circle  $|z - i| = 2$  in the positive sense when;

$$\text{a) } g(z) = \frac{1}{z^2+4}$$

$$\text{b) } g(z) = \frac{1}{(z^2+4)^2}$$

5. Let  $C$  be the circle  $|z| = 3$ , described in the positive sense. Show that if

$$g(z) = \int_C \frac{2s^2-s-2}{s-z} ds; |z| \neq 3$$

then  $g(2) = 8\pi i$ . What is the value of  $g(z)$  when  $|z| > 3$ ?

6. Let  $C$  be any simple closed contour, described in the positive sense in the  $z$  plane, and write

$$g(z) = \int_C \frac{s^3+2s}{(s-z)^3} ds$$

Show that  $g(z) = 6\pi iz$  when  $z$  is inside  $C$  and that  $g(z) = 0$  when  $z$  is outside.

7. Show that if  $f$  is analytic within and on a simple closed contour  $C$  and  $z_0$  is not on  $C$  then

$$\int_C \frac{f'(z)}{z-z_0} dz = \int_C \frac{f(z)}{(z-z_0)^2} dz$$

8. Evaluate  $\int_C xy dx + x^2 dy$  where  $C$  is the graph of  $y = x^3$   
 $-1 \leq x \leq 2$
9. Evaluate  $\oint_C x dx$  where  $C$  is the circle defined by  $x = \cos t, y = \sin t$   
with  $0 \leq t \leq 2\pi$
10. Evaluate  $\int_C \bar{z} dz$  where  $C$  is given by  $x = 3t, y = t^2$  with  $-1 \leq t \leq 4$
11. Evaluate  $\oint_C \frac{1}{z} dz$   $C$  is the circle  $x = \cos t, y = \sin t$  with  $0 \leq t \leq 2\pi$

**AN EXTENSION OF THE CAUCHY INTEGRAL FORMULA OR DERIVATIVES OF AN ANALYTIC FUNCTION**

The Cauchy integral formula can be extended so as to provide an integral representation for derivatives of  $f$  at  $z_0$ .

**THEOREM:**

Let  $f$  be an analytic everywhere inside and on a simple closed contour  $C$ , taken in the positive sense. If  $z_0$  is any point interior to  $C$  then

$$f^n(z_0) = \frac{n!}{2\pi i} \int_C \frac{f(z)}{(z-z_0)^{n+1}} dz ; n = 0,1,2, \dots \dots \dots$$

**Proof:**

Since  $f$  is analytic everywhere inside and on a simple closed contour  $C$ , taken in the positive sense. And  $z_0$  is any point interior to  $C$  then by using Cauchy Integral Formula

$$f(z_0) = \frac{1}{2\pi i} \int_C \frac{f(z)}{z-z_0} dz \dots \dots \dots (i)$$

$$f(z_0 + h) = \frac{1}{2\pi i} \int_C \frac{f(z)}{z-(z_0+h)} dz \dots \dots \dots (ii) \quad \text{for } z = z_0 + h \text{ on } C$$

Since we know that  $f'(z_0) = \lim_{h \rightarrow 0} \frac{f(z_0+h)-f(z_0)}{h}$

$$\Rightarrow f'(z_0) = \lim_{h \rightarrow 0} \frac{1}{h} [f(z_0 + h) - f(z_0)]$$

$$\Rightarrow f'(z_0) = \lim_{h \rightarrow 0} \frac{1}{h} \left[ \frac{1}{2\pi i} \int_C \frac{f(z)}{z-(z_0+h)} dz - \frac{1}{2\pi i} \int_C \frac{f(z)}{z-z_0} dz \right] \quad \text{using (i),(ii)}$$

$$\Rightarrow f'(z_0) = \lim_{h \rightarrow 0} \frac{1}{2\pi i h} \int_C f(z) dz \left[ \frac{1}{z-(z_0+h)} - \frac{1}{z-z_0} \right]$$

$$\Rightarrow f'(z_0) = \lim_{h \rightarrow 0} \frac{1}{2\pi i} \int_C \frac{f(z) dz}{(z-z_0)(z-z_0-h)} \quad \text{after solving}$$

$$\Rightarrow f'(z_0) = \frac{1}{2\pi i} \int_C \frac{f(z) dz}{(z-z_0)(z-z_0)} \Rightarrow f'(z_0) = \frac{1}{2\pi i} \int_C \frac{f(z) dz}{(z-z_0)^2} \dots \dots \dots (iii)$$

$$\text{Let } \Rightarrow f'(z_0 + h) = \frac{1}{2\pi i} \int_C \frac{f(z) dz}{(z-(z_0+h))^2} \dots \dots \dots (iv)$$

Since we know that  $f''(z_0) = \lim_{h \rightarrow 0} \frac{f'(z_0+h)-f'(z_0)}{h}$

$$\Rightarrow f''(z_0) = \lim_{h \rightarrow 0} \frac{1}{h} [f'(z_0 + h) - f'(z_0)]$$

$$\Rightarrow f''(z_0) = \lim_{h \rightarrow 0} \frac{1}{h} \left[ \frac{1}{2\pi i} \int_C \frac{f(z) dz}{(z-(z_0+h))^2} - \frac{1}{2\pi i} \int_C \frac{f(z) dz}{(z-z_0)^2} \right] \quad \text{using (iii),(iv)}$$

$$\Rightarrow f''(z_0) = \lim_{h \rightarrow 0} \frac{1}{h} \frac{1}{2\pi i} \int_C f(z) dz \left[ \frac{1}{(z-(z_0+h))^2} - \frac{1}{(z-z_0)^2} \right]$$

$$\Rightarrow f''(z_0) = \lim_{h \rightarrow 0} \frac{2}{2\pi i} \left[ \int_C \frac{(z-(z_0+\frac{h}{2}))f(z) dz}{(z-(z_0+h))^2(z-z_0)^2} \right] \quad \text{after solving}$$

$$\Rightarrow f''(z_0) = \frac{2!}{2\pi i} \left[ \int_C \frac{(z-z_0)f(z) dz}{(z-z_0)^2(z-z_0)^2} \right] \Rightarrow f''(z_0) = \frac{2!}{2\pi i} \int_C \frac{f(z)}{(z-z_0)^{2+1}} dz$$

Continuing in this manner we can get the required. i.e.

$$f^n(z_0) = \frac{n!}{2\pi i} \int_C \frac{f(z)}{(z-z_0)^{n+1}} dz ; n = 0,1,2, \dots \dots \dots$$

**Remark:**

We can compare this result with real variable theory that “if the derivative of a function exists its further derivative may or may not exist” unlike complex variables theory that “if a function is analytic at a point, all its other derivatives exist at that point”.

**Example:**

Evaluate the integral  $\int_C \frac{6z^2 - 2z + 5}{(z-1)^3} dz$  where  $C$  encloses the point  $z = 1$ .

**Solution:** Given that  $f(z) = 6z^2 - 2z + 5$ ;  $n = 2, z_0 = 1$

$$\Rightarrow f'(z) = 12z - 2 \Rightarrow f''(z) = 12 \Rightarrow f''(1) = 12$$

Now by using the formula  $f^n(z_0) = \frac{n!}{2\pi i} \int_C \frac{f(z)}{(z-z_0)^{n+1}} dz$

$$\Rightarrow f''(1) = \frac{2!}{2\pi i} \int_C \frac{6z^2 - 2z + 5}{(z-1)^{2+1}} dz \Rightarrow f''(1) = \frac{2}{2\pi i} \int_C \frac{6z^2 - 2z + 5}{(z-1)^3} dz$$

$$\Rightarrow \pi i f''(1) = \int_C \frac{6z^2 - 2z + 5}{(z-1)^3} dz \Rightarrow \int_C \frac{6z^2 - 2z + 5}{(z-1)^3} dz = 12\pi i$$

**Example:**

Evaluate the integral  $\int_C \frac{e^{2z} + \text{Sin}z}{(z+1)^4} dz$  where  $C$  encloses the point  $z = -1$ .

**Solution:** Given that  $f(z) = e^{2z} + \text{Sin}z$ ;  $n = 3, z_0 = -1$

$$\Rightarrow f'(z) = 2e^{2z} + \text{Cos}z \Rightarrow f''(z) = 4e^{2z} - \text{Sin}z \Rightarrow f'''(z) = 8e^{2z} - \text{Cos}z$$

$$\Rightarrow f'''(-1) = 8e^{-2} - \text{Cos}(-1)$$

Now by using the formula  $f^n(z_0) = \frac{n!}{2\pi i} \int_C \frac{f(z)}{(z-z_0)^{n+1}} dz$

$$\Rightarrow f'''(-1) = \frac{3!}{2\pi i} \int_C \frac{e^{2z} + \text{Sin}z}{(z-(-1))^{3+1}} dz \Rightarrow f'''(-1) = \frac{6}{2\pi i} \int_C \frac{e^{2z} + \text{Sin}z}{(z+1)^4} dz$$

$$\Rightarrow \frac{\pi}{3} i f'''(-1) = \int_C \frac{e^{2z} + \text{Sin}z}{(z+1)^4} dz \Rightarrow \int_C \frac{e^{2z} + \text{Sin}z}{(z+1)^4} dz = \frac{\pi}{3} i (8e^{-2} - \text{Cos}(-1))$$

**Exercise 39: (visit @ Youtube “learning with Usman Hamid”)**

1. If  $C$  is the positively oriented unit circle  $|z|=1$  then evaluate the integral  $\int_C \frac{e^{2z}}{z^4} dz$
2. Let  $z_0$  be any point interior to a positively oriented simple closed contour  $C$ . Then show that  $\int_C \frac{dz}{z-z_0} = 2\pi i$  also  $\int_C \frac{dz}{(z-z_0)^{n+1}} = 0$

## SOME CONSEQUENCES OF THE EXTENSION

We turn now to some important consequences of the extension of the Cauchy integral formula in the previous section.

**Theorem (just read):** *If a function  $f$  is analytic at a given point, then its derivatives of all orders are analytic there too.*

**Corollary (just read):** *If a function  $f = u + iv$  is analytic at a given point, then its components  $u, v$  have continuous partial derivatives of all orders at that point.*

The proof of the next theorem, due to E. Morera (1856–1909), depends on the fact that the derivative of an analytic function is itself analytic.

### MORERA'S THEOREM

*(may be regarded as converse of Cauchy Fundamental Theorem)*

*Let  $f$  be continuous on a domain  $D$ . If  $\int_C f(z)dz = 0$  for every closed contour  $C$  in  $D$ , then  $f$  is analytic throughout  $D$ .*

**Proof:**

Let  $z_0 = a$  be a fixed point and  $z$  be a variable point in  $D$ , also let  $C$  be a closed curve consisting of  $C_1$  and  $-C_2$  then by using consequence of Cauchy Fundamental theorem  $\int_{C_1} f(z)dz = \int_{C_2} f(z)dz$

Let  $F(z) = \int_{z_0=a}^z f(t)dt \dots\dots\dots(i)$  and  $F(z+h) = \int_{z_0=a}^{z+h} f(t)dt \dots\dots\dots(ii)$

$$\Rightarrow F(z+h) - F(z) = \int_{z_0=a}^{z+h} f(t)dt - \int_{z_0=a}^z f(t)dt$$

$$\Rightarrow F(z+h) - F(z) = \int_a^{z+h} f(t)dt + \int_z^a f(t)dt$$

$$\Rightarrow F(z+h) - F(z) = \int_z^a f(t)dt + \int_a^{z+h} f(t)dt = \int_z^{z+h} f(t)dt$$

$$\Rightarrow \frac{1}{h} [F(z+h) - F(z)] = \frac{1}{h} \int_z^{z+h} f(t)dt$$

$$\Rightarrow \frac{1}{h} [F(z+h) - F(z)] - f(z) = \frac{1}{h} \int_z^{z+h} f(t)dt - f(z)$$

$$\Rightarrow \frac{1}{h} [F(z+h) - F(z)] - f(z) = \frac{1}{h} \int_z^{z+h} f(t)dt - \frac{f(z)}{h} h$$

$$\Rightarrow \frac{1}{h} [F(z+h) - F(z)] - f(z) = \frac{1}{h} \int_z^{z+h} f(t)dt - \frac{1}{h} \int_z^{z+h} f(z)dt$$

Where we use the fact  $h = \int_z^{z+h} dt$ ; the length of interval

$$\Rightarrow \frac{1}{h} [F(z+h) - F(z)] - f(z) = \frac{1}{h} \left[ \int_z^{z+h} f(t)dt - \int_z^{z+h} f(z)dt \right]$$

$$\Rightarrow \frac{1}{h} [F(z+h) - F(z)] - f(z) = \frac{1}{h} \left[ \int_z^{z+h} (f(t) - f(z))dt \right]$$

$$\Rightarrow \left| \frac{F(z+h) - F(z)}{h} - f(z) \right| = \left| \frac{1}{h} \left[ \int_z^{z+h} (f(t) - f(z))dt \right] \right|$$

$$\Rightarrow \left| \frac{F(z+h) - F(z)}{h} - f(z) \right| \leq \frac{1}{h} \int_z^{z+h} |f(t) - f(z)| |dt| < \frac{1}{h} \cdot \epsilon \cdot h$$

$$\Rightarrow \left| \frac{F(z+h) - F(z)}{h} - f(z) \right| < \epsilon \Rightarrow \lim_{h \rightarrow 0} \frac{F(z+h) - F(z)}{h} = f(z)$$

$\Rightarrow F'(z) = f(z) \Rightarrow f$  is analytic throughout  $D$



**CAUCHY'S INEQUALITY**

Suppose that a function  $f$  is analytic inside and on a positively oriented circle  $C$ , centered at  $z_0$  and with radius  $R$  (Fig). If  $M$  denotes the maximum value of  $|f(z)|$  on  $C$ , then  $|f^n(z_0)| \leq \frac{n!M}{R^n}$

OR

Suppose that a function  $f$  is analytic on a closed contour  $C: |z - z_0| = R$ , and  $f(z)$  is bounded i.e.  $|f(z)| \leq M$  then  $|f^n(z_0)| \leq \frac{n!M}{R^n}$

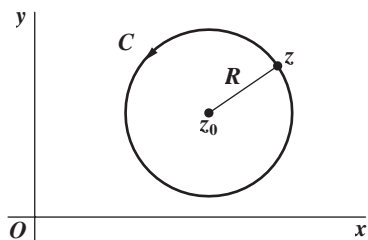

**Proof:** if  $f(z)$  is analytic and  $C: |z - z_0| = R$  then by using the result

$$f^n(z_0) = \frac{n!}{2\pi i} \int_C \frac{f(z)}{(z-z_0)^{n+1}} dz$$

$$|f^n(z_0)| = \left| \frac{n!}{2\pi i} \int_C \frac{f(z)}{(z-z_0)^{n+1}} dz \right| \leq \frac{n!}{2\pi|i|} \int_C \frac{|f(z)||dz|}{|z-z_0|^{n+1}}$$

Since  $|i| = 1$ ,  $|f(z)| \leq M$  and  $C: |z - z_0| = R$  also

$\int_C |dz| = 2\pi R$  (circle circumference) therefore

$$|f^n(z_0)| \leq \frac{n!}{2\pi} \frac{M \cdot 2\pi R}{R^{n+1}} = \frac{n!M}{R^n}$$

Thus  $|f^n(z_0)| \leq \frac{n!M}{R^n}$

Cauchy Inequality is called an immediate consequence of the expression

$$f^n(z_0) = \frac{n!}{2\pi i} \int_C \frac{f(z)}{(z-z_0)^{n+1}} dz ; n = 0, 1, 2, \dots \dots \dots$$

**Remark:**

- As  $R \rightarrow \infty$ ,  $f^n(z_0) \rightarrow 0$
- Cauchy's inequality can be used to show that no entire function except a constant is bounded in the complex plane.

**ENTIRE FUNCTION:**

A function which is analytic everywhere in the complex plane is called Entire Function, for example: All polynomials and Transcendental Functions are entire functions.

### LIUVILLE'S THEOREM

If a function  $f$  is entire and bounded in the complex plane, then  $f(z)$  is constant throughout the plane.

**Proof:**

Since  $f(z)$  is analytic everywhere in the complex plane and it is bounded therefore by using Cauchy inequality

$$|f^n(z_0)| \leq \frac{n!M}{R^n} \quad \text{where } C: |z - z_0| = R$$

Put  $n = 1$  and  $z_0 = z$  then  $|f'(z)| \leq \frac{M}{R}$

If  $R \rightarrow \infty$ ,  $f'(z) \rightarrow 0$  means that  $f(z)$  is constant.

### REMARK:

Sometime this question appears in the form

Prove liouville's theorem by using Cauchy integral formula. Also show that derivative of the function vanishes identically.

In this situation, 1<sup>st</sup> take Cauchy integral formula, take its absolute value and proceed.

### FUNDAMENTAL THEOREM OF ALGEBRA:

Any polynomial  $P(z) = a_0 + a_1z + a_2z^2 + \dots + a_nz^n$  ( $a_n \neq 0$ ) of degree  $n$  ( $n \geq 1$ ) has at least one zero.

That is, there exists at least one point  $z$  such that  $P(z) = 0$ .

**Proof:**

We shall use Liouville's Theorem in order to prove this theorem and we shall prove it by contradiction.

Suppose that theorem is false so that  $P(z) \neq 0$  for any 'z' then the function

$f(z) = \frac{1}{P(z)}$  is analytic everywhere.

$$\Rightarrow f(z) = \frac{1}{P(z)} = \frac{1}{a_0 + a_1z + a_2z^2 + \dots + a_nz^n}$$

$$\Rightarrow f(z) = \frac{1}{z^n \left[ \frac{a_0}{z^n} + \frac{a_1}{z^{n-1}} + \frac{a_2}{z^{n-2}} + \dots + a_n \right]} \rightarrow 0 \quad \text{as } z \rightarrow \infty$$

Hence for every  $\epsilon > 0$  there exists  $\delta > 0$  such that  $|f(z)| < \epsilon$  for  $|z| > \delta$

Also  $f(z)$  is continuous in the bounded closed domain  $|z| \leq \delta$ , therefore there exists a number  $C$  such that  $|f(z)| < C$  for  $|z| \leq \delta$

Let  $M = \max(\epsilon, C)$  then  $|f(z)| = \left| \frac{1}{P(z)} \right| < M$  for every 'z'

Hence by Liouville's Theorem  $f(z)$  is constant. But  $P(z)$  is not constant for  $n = 0, 1, 2, 3, \dots$ . And  $a_n \neq 0$

Therefore  $P(z)$  must be zero for at least one value of 'z'. and the equation  $P(z) = 0$  must have at least one root.

**Remark:**

Every polynomial  $P(z) = a_0 + a_1z + a_2z^2 + \cdots + a_nz^n$  ( $a_n \neq 0$ ) of degree  $n$  ( $n \geq 1$ ) has exactly 'n' roots.

**Corollary(just read):**

*Suppose that a function  $f$  is continuous on a closed bounded region  $R$  and that it is analytic and not constant in the interior of  $R$ . Then the maximum value of  $|f(z)|$  in  $R$ , which is always reached, occurs somewhere on the boundary of  $R$  and never in the interior.*

**Lemma:**

*Suppose that  $|f(z)| \leq |f(z_0)|$  at each point  $z$  in some neighborhood  $|z - z_0| < \varepsilon$  in which  $f$  is analytic. Then  $f(z)$  has the constant value  $f(z_0)$  throughout that neighborhood.*

This lemma can be used to prove the following theorem, which is known as the **maximum modulus principle**.

**MAXIMUM MODULUS PRINCIPLE**

If a function  $f$  is analytic and not constant in a given domain  $D$ , then  $|f(z)|$  has no maximum value in  $D$ . That is, there is no point  $z_0$  in the domain such that  $|f(z)| \leq |f(z_0)|$  for all points  $z$  in it.

**OR** If a function  $f$  is analytic within and on a simple closed curve then  $|f(z)|$  attain its maximum value on the  $C$  (not inside)

**Proof:**

Since  $f$  is analytic therefore it is continuous on and within  $C$ , then  $f$  attain its maximum value on and within  $C$ .

Now we have to show that  $|f(z)|$  attain its maximum value on  $C$  (not inside)  
Suppose that  $f(z)$  is not constant. Then consider it attains its maximum value within  $C$  not on the boundary of  $C$ .

i.e.  $|f(z)| = M$  when  $z = a$  within  $C$  .....(i)

let  $C_1$  be another circle inside  $C$  centered at 'a'

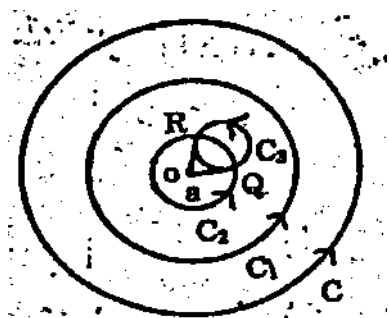

since  $f(z)$  is not constant and it attains its maximum value at 'a'.

therefore there must exist  $z = b$  inside  $C_1$  such that  $|f(b)| < M$

let  $|f(b)| = M - \epsilon$  where  $\epsilon > 0$

also as  $|f(z)|$  is continuous at  $z = b$  then for any  $\epsilon > 0$  there exists  $\delta > 0$  such that  $||f(z)| - |f(b)|| < \frac{\epsilon}{2}$  whenever  $|z - b| < \delta$

therefore  $||f(z)| - |f(b)|| \geq |f(z)| - |f(b)|$

$|f(z)| - |f(b)| < \frac{\epsilon}{2} \Rightarrow |f(z)| < |f(b)| + \frac{\epsilon}{2} \Rightarrow |f(z)| < M - \epsilon + \frac{\epsilon}{2}$

$\Rightarrow |f(z)| < M - \frac{\epsilon}{2}$  .....(ii)

$\Rightarrow f(z) = M \Rightarrow f(z)$  attain its maximum value at 'b'

If  $C_2$  be another circle inside  $C_1$  centered at 'b' and  $|f(z)| < M$  at all 'z' except 'b'. then draw another circle  $C_3$  with radius  $r = |b - a|$  lying within  $C_2$  so that on this we have  $|f(z)| < M - \frac{\epsilon}{2}$

Now by Cauchy Integral Formula  $f(a) = \frac{1}{2\pi i} \int_{C_3} \frac{f(z)}{z-a} dz$

Then put  $z - a = re^{i\theta} \Rightarrow z = a + re^{i\theta} \Rightarrow dz = ire^{i\theta} d\theta$

$$\text{Then } f(a) = \frac{1}{2\pi i} \int_0^{2\pi} \frac{f(a+re^{i\theta})}{re^{i\theta}} ire^{i\theta} d\theta = \frac{1}{2\pi} \int_0^{2\pi} f(a+re^{i\theta}) d\theta$$

$$\Rightarrow f(a) = \frac{1}{2\pi} \int_0^{\infty} f(a+re^{i\theta}) d\theta + \frac{1}{2\pi} \int_{\infty}^{2\pi} f(a+re^{i\theta}) d\theta$$

$$\Rightarrow |f(a)| = \left| \frac{1}{2\pi} \int_0^{\infty} f(a+re^{i\theta}) d\theta + \frac{1}{2\pi} \int_{\infty}^{2\pi} f(a+re^{i\theta}) d\theta \right|$$

$$\Rightarrow |f(a)| \leq \frac{1}{2\pi} \int_0^{\infty} |f(a+re^{i\theta})| d\theta + \frac{1}{2\pi} \int_{\infty}^{2\pi} |f(a+re^{i\theta})| d\theta$$

$$\Rightarrow |f(a)| < \frac{1}{2\pi} \int_0^{\infty} \left( M - \frac{\epsilon}{2} \right) d\theta + \frac{1}{2\pi} \int_{\infty}^{2\pi} M d\theta$$

$$\Rightarrow |f(a)| < \frac{1}{2\pi} \left( M - \frac{\epsilon}{2} \right) |\theta|_0^{\infty} + \frac{1}{2\pi} M |\theta|_{\infty}^{2\pi} = \frac{1}{2\pi} \left( M - \frac{\epsilon}{2} \right) (\infty) + \frac{1}{2\pi} M (2\pi - \infty)$$

$$\Rightarrow |f(a)| < \frac{M\infty}{2\pi} - \frac{\infty\epsilon}{4\pi} + M - \frac{M\infty}{2\pi} \Rightarrow |f(a)| < M - \frac{\infty\epsilon}{4\pi} \dots\dots\dots(iii)$$

From (i) and (iii)

$$M = |f(z)| < M - \frac{\infty\epsilon}{4\pi} \quad \text{a contradiction.}$$

So If  $f$  is analytic within and on a simple closed curve then  $|f(z)|$  attain its maximum value on the C (not inside)

### MINIMUM MODULUS PRINCIPLE

If ' $m$ ' is the minimum value of  $|f(z)|$  inside and on C then unless  $f$  is constant  $|f(z)| > m$  for every point  $z = z_0$  inside C

**OR** If a function  $f$  is analytic within and on a closed curve and let  $f(z) \neq 0$  inside C then  $f(z)$  must attain its minimum value (say) ' $m$ ' on C (not inside)

#### Proof:

Since  $f$  is analytic inside and on C and  $f(z) \neq 0$  therefore  $\frac{1}{f(z)}$  is analytic on and within C. then by maximum modulus principle  $\frac{1}{|f(z)|}$  cannot attain its maximum value inside C and consequently  $|f(z)|$  cannot attain its minimum value inside C. also  $f(z)$  is continuous on and within C therefore  $|f(z)|$  must attain its minimum value at some point on C (not inside)

**Exercise 40:** Find the maximum modulus of  $f(z) = 2z + 5i$  on the closed circular region defined by  $|z| \leq 2$

**POISSONS' INTEGRAL FORMULA**

Let  $f(z)$  be analytic in the region  $|z| < \rho$  and let  $|z| = re^{i\theta}$  be any point of this region. Then

$$f(re^{i\theta}) = \frac{1}{2\pi} \int_0^{2\pi} \frac{(R^2 - r^2)}{R^2 - 2rR\cos(\varphi - \theta) + r^2} f(Re^{i\varphi}) d\varphi$$

Where  $R$  is any number such that  $r < R < \rho$

**Proof:**

Let  $C$  denote the circle  $|w| = R$  such that  $|z| = r < R < \rho$  also  $|z| = re^{i\theta}$  is any point of the region  $|z| < \rho$  where  $r < R < \rho$ . Hence by Cauchy Integral Formula we get

$$f(z) = \frac{1}{2\pi i} \int_C \frac{f(w)}{w - z} dw \dots\dots\dots(i)$$

Let  $|z|^2 = z\bar{z} = R^2 \Rightarrow z = \frac{R^2}{\bar{z}}$  lies outside the  $C$ , so that the function  $\frac{f(w)}{w - \frac{R^2}{\bar{z}}}$  is

analytic on and within  $C$ . therefore by Cauchy Fundamental Theorem

$$f(z) = \frac{1}{2\pi i} \int_C \frac{f(w)}{w - z} dw = 0$$

$$\Rightarrow \frac{1}{2\pi i} \int_C \frac{f(w)}{w - \frac{R^2}{\bar{z}}} dw = 0 \dots\dots\dots(ii)$$

Subtracting (ii) from (i)  $f(z) - 0 = \frac{1}{2\pi i} \int_C \frac{f(w)}{w - z} dw - \frac{1}{2\pi i} \int_C \frac{f(w)}{w - \frac{R^2}{\bar{z}}} dw$

$$f(z) = \frac{1}{2\pi i} \int_C \left[ \frac{1}{w - z} - \frac{1}{w - \frac{R^2}{\bar{z}}} \right] f(w) dw = \frac{1}{2\pi i} \int_C \left[ \frac{z - \frac{R^2}{\bar{z}}}{(w - z)(w - \frac{R^2}{\bar{z}})} \right] f(w) dw$$

Now using  $z = re^{i\theta}, \bar{z} = re^{-i\theta}, w = Re^{i\varphi}, dw = iRe^{i\varphi} d\varphi$

$$\Rightarrow f(z) = \frac{1}{2\pi i} \int_0^{2\pi} \left[ \frac{re^{i\theta} - \frac{R^2}{re^{-i\theta}}}{(Re^{i\varphi} - re^{i\theta})(Re^{i\varphi} - \frac{R^2}{re^{-i\theta}})} \right] f(Re^{i\varphi}) iRe^{i\varphi} d\varphi$$

$$\Rightarrow f(z) = \frac{1}{2\pi} \int_0^{2\pi} \left[ \frac{\frac{r^2 - R^2}{re^{-i\theta}}}{(Re^{i\varphi} - re^{i\theta}) \left( \frac{rRe^{i\varphi}e^{-i\theta} - R^2}{re^{-i\theta}} \right)} \right] f(Re^{i\varphi}) Re^{i\varphi} d\varphi$$

$$\Rightarrow f(z) = \frac{1}{2\pi} \int_0^{2\pi} \left[ \frac{\frac{r^2 - R^2}{re^{-i\theta}}}{(Re^{i\varphi} - re^{i\theta}) Re^{i\varphi} \left( \frac{re^{-i\theta} - Re^{-i\varphi}}{re^{-i\theta}} \right)} \right] f(Re^{i\varphi}) Re^{i\varphi} d\varphi$$

$$\Rightarrow f(z) = \frac{1}{2\pi} \int_0^{2\pi} \left[ \frac{r^2 - R^2}{re^{-i\theta} (Re^{i\varphi} - re^{i\theta}) \left( \frac{re^{-i\theta} - Re^{-i\varphi}}{re^{-i\theta}} \right)} \right] f(Re^{i\varphi}) d\varphi$$

$$\Rightarrow f(z) = \frac{1}{2\pi} \int_0^{2\pi} \left[ \frac{r^2 - R^2}{(Re^{i\varphi} - re^{i\theta})(re^{-i\theta} - Re^{-i\varphi})} \right] f(Re^{i\varphi}) d\varphi$$

$$\Rightarrow f(z) = \frac{1}{2\pi} \int_0^{2\pi} \left[ \frac{r^2 - R^2}{R^2 - rR \left\{ \left( \frac{e^{i(\varphi - \theta)} + e^{-i(\varphi - \theta)}}{2} \right)^2 + r^2 \right\}} \right] f(Re^{i\varphi}) d\varphi$$

$$\Rightarrow f(re^{i\theta}) = \frac{1}{2\pi} \int_0^{2\pi} \frac{(R^2 - r^2)}{R^2 - 2rR\cos(\varphi - \theta) + r^2} f(Re^{i\varphi}) d\varphi$$

---

**SERIES**

This chapter is devoted mainly to series representations of analytic functions. We present theorems that guarantee the existence of such representations, and we develop some facility in manipulating series.

**SEQUENCES**

A sequence  $z_n$  is a function whose domain is the set of natural numbers and range is a subset of complex numbers.

**CONVERGENCE OF SEQUENCES**

An infinite *sequence*  $z_1, z_2, \dots, z_n, \dots$  of complex numbers has a **limit**  $z$  if, for each positive number  $\varepsilon$ , there exists a positive integer  $n_0$  such that  $|z_n - z| < \varepsilon$  whenever  $n > n_0$ .

Geometrically, this means that for sufficiently large values of  $n$ , the points  $z_n$  lie in any given  $\varepsilon$  neighborhood of  $z$  (Fig.). Since we can choose  $\varepsilon$  as small as we please, it follows that the points  $z_n$  become arbitrarily close to  $z$  as their subscripts increase. Note that the value of  $n_0$  that is needed will, in general, depend on the value of  $\varepsilon$ .

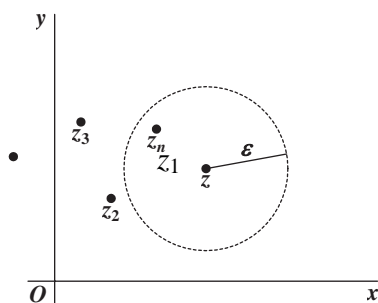

A sequence can have at most one limit. That is, a limit  $z$  is unique if it exists. When that limit exists, the sequence is said to **converge** to  $z$ ; and we write

$$\lim_{n \rightarrow \infty} z_n = z$$

If the sequence has no limit, it *diverges*.

**Theorem: (Criteria for Convergence)**

Suppose that  $z_n = x_n + iy_n$  ( $n = 1, 2, \dots$ ) and  $z = x + iy$ . Then  $\lim_{n \rightarrow \infty} z_n = z$  if and only if  $\lim_{n \rightarrow \infty} x_n = x$  and  $\lim_{n \rightarrow \infty} y_n = y$

**Proof:** To prove this theorem, we first assume that conditions  $\lim_{n \rightarrow \infty} z_n = z$  hold, there exist, for each positive number  $\varepsilon$ , positive integers  $n_1$  and  $n_2$  such that

$$|x_n - x| < \frac{\varepsilon}{2} \quad \text{whenever} \quad n > n_1$$

And  $|y_n - y| < \frac{\varepsilon}{2}$  whenever  $n > n_2$

Hence if  $n_0$  is the larger of the two integers  $n_1$  and  $n_2$ ,

$|x_n - x| < \frac{\varepsilon}{2}$  and  $|y_n - y| < \frac{\varepsilon}{2}$  whenever  $n > n_0$

Since  $|z_n - z| = |(x_n + iy_n) - (x + iy)| = |(x_n - x) + i(y_n - y)|$

$|z_n - z| < \frac{\varepsilon}{2} + \frac{\varepsilon}{2} = \varepsilon$  whenever  $n > n_0$

$\lim_{n \rightarrow \infty} z_n = z$  holds

Conversely, if we start with condition  $\lim_{n \rightarrow \infty} z_n = z$ , we know that for each positive number  $\varepsilon$ , there exists a positive integer  $n_0$  such that

$|(x_n + iy_n) - (x + iy)| < \varepsilon$  whenever  $n > n_0$ .

But  $|x_n - x| \leq |(x_n - x) + i(y_n - y)| = |(x_n + iy_n) - (x + iy)|$

And  $|y_n - y| \leq |(x_n - x) + i(y_n - y)| = |(x_n + iy_n) - (x + iy)|$ ;

and this means that  $|x_n - x| < \varepsilon$  and  $|y_n - y| < \varepsilon$  whenever  $n > n_0$

that is, conditions  $\lim_{n \rightarrow \infty} x_n = x$  and  $\lim_{n \rightarrow \infty} y_n = y$  are satisfied.

**Example:**

Show that the sequence  $z_n = -1 + i \frac{(-1)^n}{n^2}$ ;  $n = 1, 2, 3, \dots$  Converges to  $-1$

**Solution:**

$\lim_{n \rightarrow \infty} \left[ -1 + i \frac{(-1)^n}{n^2} \right] = \lim_{n \rightarrow \infty} [-1] + i \lim_{n \rightarrow \infty} \left[ \frac{(-1)^n}{n^2} \right] = -1 + i \cdot 0 = -1$

**Another way:**

$|z_n - (-1)| = \left| -1 + i \frac{(-1)^n}{n^2} - (-1) \right| = \left| i \frac{(-1)^n}{n^2} \right| = \frac{1}{n^2} < \varepsilon$  whenever  $n > \frac{1}{\sqrt{\varepsilon}}$

**Example:**

Show that the sequence  $z_n = \frac{3+ni}{n+2ni}$  Converges to  $\frac{2}{5} + \frac{1}{5}i$

**Solution:**

$\lim_{n \rightarrow \infty} \left[ \frac{3+ni}{n+2ni} \right] = \lim_{n \rightarrow \infty} \left[ \frac{n(\frac{3}{n}+i)}{n(1+2i)} \right] = \lim_{n \rightarrow \infty} \left[ \frac{(\frac{3}{n}+i)}{(1+2i)} \right] = \frac{2}{5} + \frac{1}{5}i$



## SERIES

Sum of the terms of the sequence  $z_n = z_1 + z_2 + \dots + z_n + \dots$  is called series and it is represented as  $\sum_{n=1}^{\infty} z_n = z_1 + z_2 + \dots + z_n + \dots$

## CONVERGENCE OF SERIES

An infinite series  $\sum_{n=1}^{\infty} z_n = z_1 + z_2 + \dots + z_n + \dots$  of complex numbers converges to the sum  $S$  if the sequence

$$S_N = \sum_{n=1}^N z_n = z_1 + z_2 + \dots + z_N \quad (N = 1, 2, \dots)$$

of partial sums converges to  $S$ ; we then write  $\sum_{n=1}^{\infty} z_n = S$

**Note that** since a sequence can have at most one limit, a series can have at most one sum. When a series does not converge, we say that it **diverges**.

**Theorem:** Suppose that  $z_n = x_n + iy_n$  ( $n = 1, 2, \dots$ ) and  $S = X + iY$ .

$$\text{Then } \sum_{n=1}^{\infty} z_n = S \Leftrightarrow \sum_{n=1}^{\infty} x_n = X \text{ and } \sum_{n=1}^{\infty} y_n = Y$$

This theorem tells us, of course, that one can write

$$\sum_{n=1}^{\infty} (x_n + iy_n) = \sum_{n=1}^{\infty} x_n + i \sum_{n=1}^{\infty} y_n$$

This theorem can be useful in showing that a number of familiar properties of series in calculus carry over to series whose terms are complex numbers. To illustrate how this is done, we include here such properties and present them as corollaries.

**Convergent Test:** If a series of complex numbers converges, the  $n$ th term converges to zero as  $n$  tends to infinity.

i.e. if  $\sum_{n=1}^{\infty} z_n$  converges then  $\lim_{n \rightarrow \infty} z_n = 0$  (Converse not holds)

**Divergent Test:** If  $\lim_{n \rightarrow \infty} z_n \neq 0$  then  $\sum_{n=1}^{\infty} z_n$  diverges

**Absolutely Convergent Series:** The absolute convergence of a series of complex numbers implies the convergence of that series.

i.e. if  $\sum_{n=1}^{\infty} |z_n|$  converges then Series  $\sum_{n=1}^{\infty} z_n$  is said to be absolutely convergent.

**Conditionally Convergent Series:**

If  $\sum_{n=1}^{\infty} |z_n|$  diverges but the Series  $\sum_{n=1}^{\infty} z_n$  Converges itself then it is said to be conditionally convergent.

**Remark:**

In real analysis  $|a_n - L| < \varepsilon \Leftrightarrow L - \varepsilon < a_n < L + \varepsilon \Rightarrow a_n \in ]L - \varepsilon, L + \varepsilon[$

But in complex analysis we cannot write as  $z_n \in ]L - \varepsilon, L + \varepsilon[$

In complex analysis, when  $|z_n - L| < \varepsilon$  then there exists a disk or circle such that  $|z_n - L| = \varepsilon$  and in this circle  $|z_n - L| < \varepsilon$  is valid.

**GEOMETRIC SERIES**

Any series of the form  $\sum_{n=1}^{\infty} az^{n-1} = a + az + az^2 + az^3 + \dots$  is called Geometric Series. It is Convergent Series and its sum is  $\sum_{n=1}^{\infty} az^{n-1} = \frac{a}{1-z}$

**OSCILLATORY SERIES**

Any series is said to be Oscillatory if neither the partial sum tends to finite and definite limit nor tends to  $+\infty$  or  $-\infty$  rather oscillate between two numbers.

**POWER SERIES**

Any series of the form

$\sum_{n=0}^{\infty} a_n(z - z_0)^n = a_0 + a_1(z - z_0)^1 + a_2(z - z_0)^2 + \dots$  is called Power Series.

**DE – ALEMBERT OR RATIO TEST**

Suppose that  $\sum_{n=1}^{\infty} z_n$  is a complex series such that  $\lim_{n \rightarrow \infty} \left| \frac{z_{n+1}}{z_n} \right| = L$  then

- i. If  $L < 1$  then series will be absolutely convergent.
- ii. If  $L > 1$  or  $L = \infty$  then series will be divergent.
- iii. If  $L = 1$  then test fail.

**ROOT TEST**

Suppose that  $\sum_{n=1}^{\infty} z_n$  is a complex series such that  $\lim_{n \rightarrow \infty} |z_n|^{1/n} = L$  then

- i. If  $L < 1$  then series will be absolutely convergent.
- ii. If  $L > 1$  then series will be divergent.
- iii. If  $L = 1$  then test fail

## ABSOLUTE AND UNIFORM CONVERGENCE OF POWER SERIES

This section and the three following it are devoted mainly to various properties of power series.

We recall that a series of complex numbers converges *absolutely* if the series of absolute values of those numbers converges. The following theorem concerns the absolute convergence of power series.

### Theorem:

If a power series  $\sum_{n=0}^{\infty} a_n(z - z_0)^n = a_0 + a_1(z - z_0)^1 + a_2(z - z_0)^2 + \dots$  converges when  $z = z_1$  ( $z_1 \neq z_0$ ), then it is absolutely convergent at each point  $z$  in the open disk  $|z - z_0| < R_1$  where  $R_1 = |z_1 - z_0|$

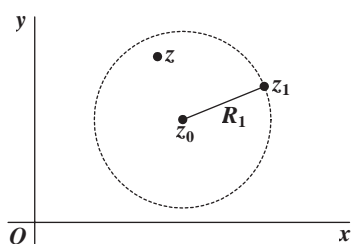

The theorem tells us that the set of all points inside some circle centered at  $z_0$  is a region of convergence for the power series, provided it converges at some point other than  $z_0$ . The greatest circle centered at  $z_0$  such that series converges at each point inside is called the *circle of convergence* of series. The series cannot converge at any point  $z_2$  outside that circle, according to the theorem; for if it did, it would converge everywhere inside the circle centered at  $z_0$  and passing through  $z_2$ . The first circle could not, then, be the circle of convergence.

### Theorem:

If  $z_1$  is a point inside the circle of convergence  $|z - z_0| = R$  of a power series  $\sum_{n=0}^{\infty} a_n(z - z_0)^n$  then that series must be uniformly convergent in the closed disk  $|z - z_0| \leq R_1$ , where  $R_1 = |z_1 - z_0|$

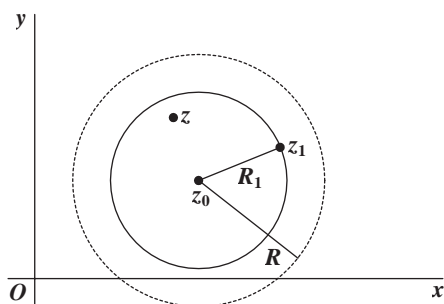

## CONTINUITY OF SUMS OF POWER SERIES

A power series  $\sum_{n=0}^{\infty} a_n(z - z_0)^n$  represents a continuous function  $S(z)$  at each point inside its circle of convergence  $|z - z_0| = R$ .

## INTEGRATION AND DIFFERENTIATION OF POWER SERIES

Let  $C$  denote any contour interior to the circle of convergence of the power series  $\sum_{n=0}^{\infty} a_n(z - z_0)^n$ , and let  $g(z)$  be any function that is continuous on  $C$ . The series formed by multiplying each term of the power series by  $g(z)$  can be integrated term by term over  $C$ ; that is,

$$\int_C g(z)S(z)dz = \sum_{n=0}^{\infty} a_n \int_C g(z)(z - z_0)^n dz$$

### Corollary:

The sum  $S(z)$  of power series  $\sum_{n=0}^{\infty} a_n(z - z_0)^n$  is analytic at each point  $z$  interior to the circle of convergence of that series.

### Theorem:

The power series  $\sum_{n=0}^{\infty} a_n(z - z_0)^n$  can be differentiated term by term. That is, at each point  $z$  interior to the circle of convergence of that series

$$S'(z) = \sum_{n=0}^{\infty} n a_n(z - z_0)^{n-1}$$

### REMARK:

- Expansion of an analytic function in a power series is unique.
- Every power series represents an analytic function inside its circle of convergence.
- The sum function  $f(z)$  of the power series  $\sum_{n=0}^{\infty} a_n z^n$  represents an analytic function inside its circle of convergence. Further, every power series possesses derivatives of all order within its circle of convergence and these derivatives are obtained through term by term differentiation of the original series.
- Differentiated power series has the same radius of convergences as the original power series.
- Integrated power series has the same radius of convergences as the original power series.

## RADIUS OF CONVERGENCE AND DISC OR CIRCLE OF CONVERGENCE

A circle centered at  $z_0$  having radius  $R > 0$  for which the power series  $\sum_{n=0}^{\infty} a_n(z - z_0)^n$  converges at every point within the circle  $|z - z_0| = R$  then  $R$  is called Radius of convergence and Region or Domain of convergenc is defined as  $|z - z_0| < R$

**HOW TO FIND RADIUS OF CONVERGENCE?**

Suppose  $\sum_{n=0}^{\infty} a_n(z - z_0)^n$  is a power series.

If  $\lim_{n \rightarrow \infty} \left| \frac{z_{n+1}}{z_n} \right| = L$  or  $\lim_{n \rightarrow \infty} |z_n|^{1/n} = L$  then

Radius of Convergence =  $R = \frac{1}{L}$

**Example:** If  $\sum_{n=0}^{\infty} \left(1 + \frac{1}{n}\right)^{n^n} z^n$  then find circle of convergence.

**Solution:** Since  $\sum_{n=0}^{\infty} a_n(z - z_0)^n = \sum_{n=0}^{\infty} \left(1 + \frac{1}{n}\right)^{n^n} (z - 0)^n$

$$\Rightarrow a_n = \left(1 + \frac{1}{n}\right)^{n^n} \quad \& \quad z_0 = 0$$

By Root test;  $\lim_{n \rightarrow \infty} |z_n|^{1/n} = L$

$$\Rightarrow L = \lim_{n \rightarrow \infty} \left| \left(1 + \frac{1}{n}\right)^{n^n} \right|^{1/n} = \lim_{n \rightarrow \infty} \left| \left(1 + \frac{1}{n}\right)^n \right| = e \quad \text{use } a_n = z_n$$

Then Radius of convergence =  $R = \frac{1}{L} = \frac{1}{e}$

Circle of Convergence is  $|z - z_0| = R \Rightarrow |z - 0| = \frac{1}{e} \Rightarrow |z| = \frac{1}{e}$

**Example:**

If  $\sum_{n=0}^{\infty} \frac{(-1)^n}{n} (z - 2i)^n$  then find disk and region of convergence.

**Solution:** Since  $\sum_{n=0}^{\infty} a_n(z - z_0)^n = \sum_{n=0}^{\infty} \frac{(-1)^n}{n} (z - 2i)^n$

$$\Rightarrow a_n = \frac{(-1)^n}{n} \quad \& \quad z_0 = 2i$$

By Ratio test;  $\lim_{n \rightarrow \infty} \left| \frac{z_{n+1}}{z_n} \right| = L$

$$\Rightarrow L = \lim_{n \rightarrow \infty} \left| \frac{\frac{(-1)^{n+1}}{n+1}}{\frac{(-1)^n}{n}} \right| \quad \text{we may use } a_n = z_n$$

$$\Rightarrow L = 1$$

Then Radius of convergence =  $R = \frac{1}{L} = 1$

Circle of Convergence is  $|z - z_0| = R \Rightarrow |z - 2i| = 1$

Region (domain) of Convergence is  $|z - z_0| < R \Rightarrow |z - 2i| < 1$

**Remark:**

The power series  $\sum_{n=0}^{\infty} a_n(z - z_0)^n$  at  $z_0 = 0$  In the complex plane.

- Either converges for all values of  $z$
- Or converges only for  $z = 0$
- Or converges for  $z$  in some region.

**Example:**

Prove that if  $R = \lim_{n \rightarrow \infty} \left| \frac{a_n}{a_{n+1}} \right|$  then the series  $\sum_{n=0}^{\infty} a_n z^n$  has radius of convergence  $R$ .

**Solution:** Suppose  $u_n = a_n z^n$  then  $u_{n+1} = a_{n+1} z^{n+1}$

By Ratio test;  $\lim_{n \rightarrow \infty} \left| \frac{u_{n+1}}{u_n} \right| = L$

$$\Rightarrow L = \lim_{n \rightarrow \infty} \left| \frac{a_{n+1} z^{n+1}}{a_n z^n} \right| = \lim_{n \rightarrow \infty} \left| \frac{a_{n+1}}{a_n} \right| |z| = \frac{1}{R} |z|$$

For convergence  $L < 1$

$$\Rightarrow L = \frac{1}{R} |z| < 1 \Rightarrow |z| < R \quad \text{hence proved.}$$

**Example:**

Prove that the two series

$$\sum_{n=0}^{\infty} \left[ \frac{1.3.5 \dots 2n-1}{2.4.6 \dots 2n} \right] \frac{(1-z)^n}{n} \quad \text{and} \quad \sum_{n=0}^{\infty} \left[ \frac{1.3.5 \dots 2n-1}{2.4.6 \dots 2n} \right] \frac{(z-1)^n}{n}$$

have same circle of convergence.

**Solution:** Since  $\sum_{n=0}^{\infty} a_n (z - z_0)^n = \sum_{n=0}^{\infty} \left[ \frac{1.3.5 \dots 2n-1}{2.4.6 \dots 2n} \right] \frac{(-1)^n}{n} (z-1)^n$

$$\Rightarrow a_n = \left[ \frac{1.3.5 \dots 2n-1}{2.4.6 \dots 2n} \right] \frac{(-1)^n}{n} \quad \& \quad a_{n+1} = \left[ \frac{1.3.5 \dots (2n-1)(2n+1)}{2.4.6 \dots 2n(2n+2)} \right] \frac{(-1)^{n+1}}{n+1}$$

By Ratio test;  $\lim_{n \rightarrow \infty} \left| \frac{z_{n+1}}{z_n} \right| = L$

$$\Rightarrow L = \lim_{n \rightarrow \infty} \left| \frac{\left[ \frac{1.3.5 \dots (2n-1)(2n+1)}{2.4.6 \dots 2n(2n+2)} \right] \frac{(-1)^{n+1}}{n+1}}{\left[ \frac{1.3.5 \dots 2n-1}{2.4.6 \dots 2n} \right] \frac{(-1)^n}{n}} \right| \quad \text{we may use } a_n = z_n$$

$$\Rightarrow L_1 = 1$$

Then Radius of convergence =  $R_1 = \frac{1}{L_1} = 1$

Also Since  $\sum_{n=0}^{\infty} b_n (z - z_0)^n = \sum_{n=0}^{\infty} \left[ \frac{1.3.5 \dots 2n-1}{2.4.6 \dots 2n} \right] \frac{1}{n} (z-1)^n$

$$\Rightarrow b_n = \left[ \frac{1.3.5 \dots 2n-1}{2.4.6 \dots 2n} \right] \frac{1}{n} \quad \& \quad b_{n+1} = \left[ \frac{1.3.5 \dots (2n-1)(2n+1)}{2.4.6 \dots 2n(2n+2)} \right] \frac{1}{n+1}$$

By Ratio test;  $\lim_{n \rightarrow \infty} \left| \frac{z_{n+1}}{z_n} \right| = L$

$$\Rightarrow L = \lim_{n \rightarrow \infty} \left| \frac{\left[ \frac{1.3.5 \dots (2n-1)(2n+1)}{2.4.6 \dots 2n(2n+2)} \right] \frac{1}{n+1}}{\left[ \frac{1.3.5 \dots 2n-1}{2.4.6 \dots 2n} \right] \frac{1}{n}} \right| \quad \text{we may use } b_n = z_n$$

$$\Rightarrow L_2 = 1$$

Then Radius of convergence =  $R_2 = \frac{1}{L_2} = 1$

$\Rightarrow R_1 = R_2$  hence both series have same circle of convergence.

**Exercise 41: (visit @ Youtube “learning with Usman Hamid”)**

- If  $\sum_{n=0}^{\infty} \frac{z^n}{n!}$  then find radius and disk of convergence. Where the series converges for all ‘z’
- If  $\sum_{n=0}^{\infty} n! z^n$  then find radius and disk of convergence. Where the series converges only for all ‘z = 0’
- If  $\sum_{n=0}^{\infty} z^n$  then find radius and disk of convergence. Where the series converges for ‘z’ in some region in the complex plane.
- If  $\sum_{n=0}^{\infty} (\log)^n z^n$  then find disk of convergence (if possible).
- If  $\sum_{n=0}^{\infty} (3 + 4i)^n z^n$  then find disk of convergence.
- Prove that the series  $1 + \frac{ab}{1.c} z + \frac{a(a+1)b(b+1)}{1.2.c(c+1)} z^2 + \dots$  has unit radius of convergence.
- Calculate the radius of convergence of the series
  - $\frac{1}{2} z + \frac{1.3}{2.5.8} z^2 + \frac{1.3.5}{2.5} z^3 + \dots$
  - $z + \frac{z^2}{2!} + \frac{z^3}{3!} + \dots + \frac{z^n}{n!}$
  - $\sum_{n=0}^{\infty} \frac{n!}{n^2} z^n$
  - $\sum_{n=0}^{\infty} \frac{i^{n+2}}{2^n} z^n$
  - $\sum_{n=0}^{\infty} \frac{z^n}{1+in^2}$
  - $\sum_{n=1}^{\infty} a_n z^n = z + \frac{a-b}{2!} z^2 + \frac{(a-b)(a-2b)}{3!} z^3 + \dots$
  - $\sum_{n=0}^{\infty} a_n z^n = \sum_{n=1}^{\infty} (n+1)^n z^n$
  - $\sum_{n=0}^{\infty} a_n z^n = 1 - kz + \frac{k(k-4)}{2!} z^2 + \frac{k(k-4)(k-8)}{3!} z^3 + \dots$
  - $\sum_{n=0}^{\infty} a_n z^n = 1 - \frac{z^2}{2!} + \frac{z^4}{4!} - \frac{z^6}{6!} + \dots$
  - $\sum_{n=0}^{\infty} a_n z^n = z - \frac{z^3}{3!} + \frac{z^5}{5!} - \frac{z^7}{7!} + \dots$
  - $\sum_{n=0}^{\infty} a_n z^n = 1 + z + 2! z^2 + 3! z^3 + \dots$
- Calculate the domain of convergence of the series
  - $\sum_{n=0}^{\infty} \frac{1.3.5\dots(2n-1)}{n!} \left(\frac{1-z}{z}\right)^n$
  - $\sum_{n=0}^{\infty} n^2 \left(\frac{z^2+1}{1+i}\right)^n$
- Prove that the domain of convergence of the series  $\sum_{n=0}^{\infty} \left(\frac{iz-1}{2+i}\right)^n$  is given by  $|z+i| < \sqrt{5}$
- Prove that the series  $\sum_{n=0}^{\infty} \frac{(-1)^n}{n \log n} (z)^n$  converges everywhere on the circle of convergence except at  $z = -1$
- Prove that the series  $z + \frac{z^2}{2} + \frac{z^3}{3} + \dots$  converges in domain  $|z| < 1$  except at  $z = -1$
- Prove that the series  $\sum_{n=0}^{\infty} 3^n \left(\frac{z}{4}\right)^n$  converges absolutely.

**ABEL'S THEOREM (M – TEST ):**

If a power series centered at  $z_0$  converges at  $z_1 \neq z_0$  then the series absolutely converges for every 'z' for which  $|z - z_0| < |z_1 - z_0|$

**Proof:** Consider a power series  $\sum_{n=0}^{\infty} a_n(z - z_0)^n$  is a convergent series at  $z_1$  then  $\lim_{n \rightarrow \infty} |a_n(z_1 - z_0)^n| = 0$  by convergence test

Implies that sequence of nth partial sum is bounded such that

$$|a_n(z_1 - z_0)^n| < M$$

$$\Rightarrow |a_n| |(z_1 - z_0)^n| < M \Rightarrow |a_n| < \frac{M}{|z_1 - z_0|^n} \Rightarrow |a_n| |z - z_0|^n < \frac{M |z - z_0|^n}{|z_1 - z_0|^n}$$

$$\Rightarrow |a_n(z - z_0)^n| < M \left| \frac{z - z_0}{z_1 - z_0} \right|^n$$

$$\Rightarrow \sum_{n=0}^{\infty} |a_n(z - z_0)^n| < M \sum_{n=0}^{\infty} \left| \frac{z - z_0}{z_1 - z_0} \right|^n \dots\dots\dots(i)$$

Now  $\sum_{n=0}^{\infty} \left| \frac{z - z_0}{z_1 - z_0} \right|^n = 1 + \left| \frac{z - z_0}{z_1 - z_0} \right|^1 + \left| \frac{z - z_0}{z_1 - z_0} \right|^2 + \dots\dots\dots$  is geometric series

which is convergent under the condition  $\left| \frac{z - z_0}{z_1 - z_0} \right| < 1$

therefore by comparison test

(i)  $\Rightarrow \sum_{n=0}^{\infty} |a_n(z - z_0)^n|$  is convergent series.

$\Rightarrow \sum_{n=0}^{\infty} a_n(z - z_0)^n$  is absolutely convergent series.

**CAUCHY'S HADAMARD THEOREM**

For every series  $\sum_{n=0}^{\infty} a_n z^n$  there exists a number  $R$  such that  $0 < R < \infty$  called radius of convergence then the series converges absolutely for every  $|z| < R$

**Proof:**

For series  $\sum_{n=0}^{\infty} a_n z^n$  there exists a number  $R = \frac{1}{L}$  where  $L = \lim_{n \rightarrow \infty} |a_n|^{1/n}$

$\Rightarrow L = \frac{1}{R} = \lim_{n \rightarrow \infty} |a_n|^{1/n}$  and  $|z| < R$  then there exists a number

$\rho$  such that  $|z| < \rho < R$

$$\Rightarrow \rho < R \Rightarrow \frac{1}{R} < \frac{1}{\rho} \Rightarrow |a_n|^{1/n} < \frac{1}{\rho} \Rightarrow |a_n| < \frac{1}{\rho^n} \Rightarrow |a_n| |z|^n < \frac{|z|^n}{\rho^n}$$

$$\sum_{n=0}^{\infty} |a_n z^n| < \sum_{n=0}^{\infty} \frac{|z|^n}{\rho^n}$$

Since  $\sum_{n=0}^{\infty} \frac{|z|^n}{\rho^n} = 1 + \frac{|z|^1}{\rho^1} + \frac{|z|^2}{\rho^2} + \dots\dots\dots$  is geometric series which is

convergent under the condition  $|z| < \rho \Rightarrow \frac{|z|}{\rho} < 1$

therefore by comparison test

$\sum_{n=0}^{\infty} |a_n z^n|$  is convergent series.

$\Rightarrow \sum_{n=0}^{\infty} a_n z^n$  is absolutely convergent series for every  $|z| < R$



**TAYLOR SERIES:**

Suppose a power series  $\sum_{n=0}^{\infty} a_n (z - z_0)^n$  represents a function within the circle of convergence  $|z - z_0| = R$  then following series is known as Taylor series in complex analysis;

$$f(z) = \sum_{n=0}^{\infty} \frac{f^n(z_0)}{n!} (z - z_0)^n$$

**SPECIAL CASE:** When  $z_0 = 0$  then Taylor Series becomes Maclaurin Series i.e.

$$f(z) = \sum_{n=0}^{\infty} \frac{f^n(0)}{n!} (z)^n$$

**TAYLOR SERIES THEOREM**

Suppose that a function  $f$  is analytic throughout a disk  $|z - z_0| < R$ , centered at  $z_0$  and with radius  $R$  (Fig.). Then  $f(z)$  has the power series representation

$$f(z) = \sum_{n=0}^{\infty} \frac{f^n(z_0)}{n!} (z - z_0)^n \quad \text{with} \quad a_n = \frac{f^n(z_0)}{n!}$$

That is, series  $f(z) = \sum_{n=0}^{\infty} \frac{f^n(z_0)}{n!} (z - z_0)^n$  converges to  $f(z)$  when  $z$  lies in the stated open disk.

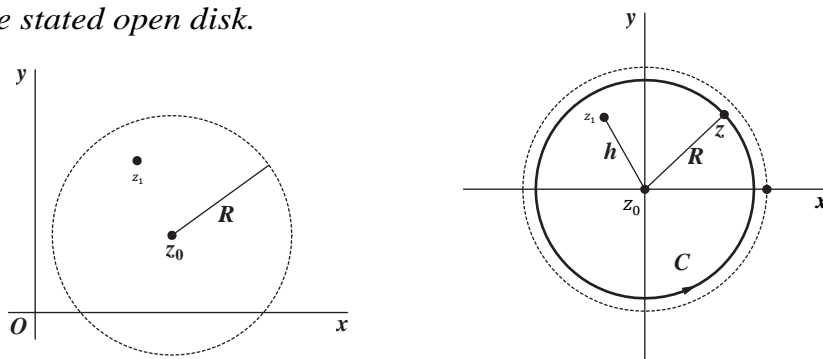
**Proof:**

Let  $C$  be a circle  $|z - z_0| < R$  centered at  $z_0$  having radius  $R$ . also consider  $z_1 = z_0 + h$  be another point inside the circle  $C$ . also function is analytic in domain  $D$ . then by using Cauchy Integral Formula

$$f(z_0 + h) = \frac{1}{2\pi i} \int_C \frac{f(z)}{z - (z_0 + h)} dz$$

$$f(z_0 + h) = \frac{1}{2\pi i} \int_C \frac{f(z)}{(z - z_0) - h} dz$$

$$f(z_0 + h) = \frac{1}{2\pi i} \int_C \frac{f(z)}{(z - z_0) \left[ 1 - \frac{h}{z - z_0} \right]} dz$$

$$f(z_0 + h) = \frac{1}{2\pi i} \int_C \frac{f(z)}{(z - z_0) \left[ 1 - \frac{h}{z - z_0} \right]^{-1}} dz \dots\dots(i)$$

Consider

$$\begin{aligned} \left[1 - \frac{h}{z-z_0}\right]^{-1} &= 1 + \frac{h}{z-z_0} + \frac{h^2}{(z-z_0)^2} + \cdots + \frac{h^n}{(z-z_0)^n} + \frac{h^{n+1}}{(z-z_0)^{n+1}} + \dots \\ \left[1 - \frac{h}{z-z_0}\right]^{-1} &= 1 + \frac{h}{z-z_0} + \frac{h^2}{(z-z_0)^2} + \cdots + \frac{h^n}{(z-z_0)^n} + \frac{h^{n+1}}{(z-z_0)^{n+1}} \left[1 + \frac{h}{z-z_0} + \frac{h^2}{(z-z_0)^2} + \cdots\right] \dots \\ \left[1 - \frac{h}{z-z_0}\right]^{-1} &= 1 + \frac{h}{z-z_0} + \frac{h^2}{(z-z_0)^2} + \cdots + \frac{h^n}{(z-z_0)^n} + \frac{h^{n+1}}{(z-z_0)^{n+1}} \left[1 - \frac{h}{z-z_0}\right]^{-1} \\ \left[1 - \frac{h}{z-z_0}\right]^{-1} &= 1 + \frac{h}{z-z_0} + \frac{h^2}{(z-z_0)^2} + \cdots + \frac{h^n}{(z-z_0)^n} + \frac{h^{n+1}}{(z-z_0)^{n+1}} \left[\frac{z-z_0-h}{z-z_0}\right]^{-1} \\ \left[1 - \frac{h}{z-z_0}\right]^{-1} &= 1 + \frac{h}{z-z_0} + \frac{h^2}{(z-z_0)^2} + \cdots + \frac{h^n}{(z-z_0)^n} + \frac{h^{n+1}(z-z_0)}{(z-z_0)^{n+1}(z-z_0-h)} \\ \left[1 - \frac{h}{z-z_0}\right]^{-1} &= 1 + \frac{h}{z-z_0} + \frac{h^2}{(z-z_0)^2} + \cdots + \frac{h^n}{(z-z_0)^n} + \frac{h^{n+1}}{(z-z_0)^n(z-z_0-h)} \dots \text{(ii)} \end{aligned}$$

$$(i) \Rightarrow f(z_0 + h) = \frac{1}{2\pi i} \int_C \frac{f(z)}{(z-z_0)} \left[1 + \frac{h}{z-z_0} + \frac{h^2}{(z-z_0)^2} + \cdots + \frac{h^n}{(z-z_0)^n} + \frac{h^{n+1}}{(z-z_0)^n(z-z_0-h)}\right] dz$$

$$\Rightarrow f(z_0 + h) = \frac{1}{2\pi i} \int_C \frac{f(z)}{(z-z_0)} dz + \frac{h}{2\pi i} \int_C \frac{f(z)}{(z-z_0)^2} dz + \frac{h^2}{2\pi i} \int_C \frac{f(z)}{(z-z_0)^3} dz + \cdots + \frac{h^n}{2\pi i} \int_C \frac{f(z)}{(z-z_0)^{n+1}} dz + \frac{h^{n+1}}{2\pi i} \int_C \frac{f(z)}{(z-z_0)^{n+1}(z-z_0-h)} dz$$

$$f(z_0 + h) = f(z_0) + \frac{h}{1!} f'(z_0) + \frac{h^2}{2!} f''(z_0) + \cdots + \frac{h^n}{n!} f^n(z_0) + R_n \dots \text{(iii)}$$

$$\text{Where } R_n = \frac{h^{n+1}}{2\pi i} \int_C \frac{f(z)}{(z-z_0)^{n+1}(z-z_0-h)} dz$$

Now we will prove  $R_n \rightarrow 0$  as  $n \rightarrow \infty$

$$\Rightarrow |R_n| = \left| \frac{h^{n+1}}{2\pi i} \int_C \frac{f(z)}{(z-z_0)^{n+1}(z-z_0-h)} dz \right|$$

$$\Rightarrow |R_n| \leq \frac{h^{n+1}}{2\pi|i|} \int_C \left| \frac{f(z)}{(z-z_0-h)} \right| \frac{|dz|}{|z-z_0|^{n+1}} < \frac{h^{n+1}}{2\pi|i|} \frac{M}{R^{n+1}} \int_C |dz|$$

$$\Rightarrow |R_n| < \frac{h^{n+1}}{2\pi|i|} \frac{M}{R^{n+1}} (2\pi R) = Mh \left(\frac{h}{R}\right)^n$$

$$\Rightarrow |R_n| < Mh \left(\frac{h}{R}\right)^n \rightarrow 0 \text{ as } n \rightarrow \infty$$

Then equation (iii) becomes

$$f(z_0 + h) = f(z_0) + \frac{h}{1!} f'(z_0) + \frac{h^2}{2!} f''(z_0) + \cdots + \frac{h^n}{n!} f^n(z_0)$$

$$f(z) = \sum_{n=0}^{\infty} \frac{f^n(z_0)}{n!} (z - z_0)^n \quad \text{with } z - z_0 = h$$

Any function which is analytic at a point  $z_0$  must have a Taylor series about  $z_0$ . For, if  $f$  is analytic at  $z_0$ , it is analytic throughout some neighborhood  $|z - z_0| < \varepsilon$  of that point; and  $\varepsilon$  may serve as the value of  $R_0$  in the statement of Taylor's theorem. Also, if  $f$  is entire,  $R$  can be chosen arbitrarily large; and the condition of validity becomes  $|z - z_0| < \infty$ . The series then converges to  $f(z)$  at each point  $z$  in the finite plane.

When it is known that  $f$  is analytic everywhere inside a circle centered at  $z_0$ , convergence of its Taylor series about  $z_0$  to  $f(z)$  for each point  $z$  within that circle is ensured; no test for the convergence of the series is even required. In fact, according to Taylor's theorem, the series converges to  $f(z)$  within the circle about  $z_0$  whose radius is the distance from  $z_0$  to the nearest point  $z_1$  at which  $f$  fails to be analytic.

### Example

Expand  $f(z) = e^z$  using Maclaurin series in the form of infinite series. Also find the region of convergence when  $z_0 = 0$

#### Solution:

$$\text{Given } f(z) = e^z \Rightarrow f(0) = 1$$

$$f'(z) = e^z \Rightarrow f'(0) = 1$$

$$f''(z) = e^z \Rightarrow f''(0) = 1$$

$$\text{Continuing in this manner } f^n(z) = e^z \Rightarrow f^n(0) = 1$$

$$\text{Using Maclaurin series } f(z) = \sum_{n=0}^{\infty} \frac{f^n(0)}{n!} (z)^n$$

$$e^z = \sum_{n=0}^{\infty} \frac{z^n}{n!} = 1 + z + \frac{z^2}{2!} + \frac{z^3}{3!} + \dots \quad \text{Required series.}$$

$$\text{Now consider } \sum_{n=0}^{\infty} a_n z^n = \sum_{n=0}^{\infty} \frac{z^n}{n!}$$

$$\Rightarrow a_n = \frac{1}{n!}, a_{n+1} = \frac{1}{(n+1)!} \text{ \& } z_0 = 0$$

$$\text{By Ratio test; } \lim_{n \rightarrow \infty} \left| \frac{z_{n+1}}{z_n} \right| = L$$

$$\Rightarrow L = \lim_{n \rightarrow \infty} \left| \frac{\frac{1}{(n+1)!}}{\frac{1}{n!}} \right| \quad \text{we may use } a_n = z_n$$

$$\Rightarrow L = \frac{1}{\infty} = 0$$

$$\text{Then Radius of convergence } = R = \frac{1}{0} = \infty$$

$$\text{Region (domain) of Convergence is } |z - z_0| < R \Rightarrow |z| < \infty$$

**Exercise 42: (visit @ Youtube “learning with Usman Hamid”)**Expand  $f(z)$  at  $z_0 = 0$  using Maclaurin series in the form of infinite series.

- i.  $\frac{1}{1-z} = \sum_{n=0}^{\infty} z^n = 1 + z + z^2 + z^3 + \dots (|z| < 1)$
- ii.  $\text{Sin}z = \sum_{n=0}^{\infty} (-1)^n \frac{z^{2n+1}}{(2n+1)!} = z - \frac{z^3}{3!} + \frac{z^5}{5!} + \dots (|z| < \infty)$
- iii.  $\text{Cos}z = \sum_{n=0}^{\infty} (-1)^n \frac{z^{2n}}{(2n)!} = 1 - \frac{z^2}{2!} + \frac{z^4}{4!} - \dots (|z| < \infty)$
- iv.  $\text{Sin}hz = \sum_{n=0}^{\infty} \frac{z^{2n+1}}{(2n+1)!} = z + \frac{z^3}{3!} + \frac{z^5}{5!} + \dots (|z| < \infty)$
- v.  $\text{Cosh}z = \sum_{n=0}^{\infty} \frac{z^{2n}}{(2n)!} = 1 + \frac{z^2}{2!} + \frac{z^4}{4!} + \dots (|z| < \infty)$
- vi.  $z\text{Cosh}(z^2) = \sum_{n=0}^{\infty} \frac{z^{4n+1}}{(2n)!} \quad (|z| < \infty)$
- vii.  $\frac{z}{1-z} = \sum_{n=0}^{\infty} z^n$
- viii.  $e^z \text{Sin}3z$
- ix.  $\frac{\text{Cosh}(2z)}{e^z} = \sum_{n=0}^{\infty} z^n$
- x.  $\frac{z}{z^4+4} \quad (|z| < \sqrt{2})$
- xii.  $\frac{e^z}{(z+1)^2} = \sum_{n=0}^{\infty} z^n$
- xi.  $\frac{1+2z^2}{z^3+z^5} \quad (|z| < 1)$
- xiii.  $\frac{2}{(1-z)^3} = \sum_{n=0}^{\infty} (n+1)(n+2)z^n \quad (|z| < 1)$
- xiv.  $\frac{\text{Sin}hz}{1+z} \quad (|z| < 1)$
- xv.  $\frac{e^z}{z(z^2+1)} \quad (0 < |z| < 1)$
- xvi.  $e^z \text{Sin}z \quad (|z| < \infty)$
- xvii.  $\frac{e^2}{1+z} \quad (|z| < 1)$

**Example:** Expand  $f(z) = \text{Sin}z$  using Taylor's series when  $z_0 = \frac{\pi}{4}$ **Solution:** Given  $f(z) = \text{Sin}z \Rightarrow f\left(\frac{\pi}{4}\right) = \frac{1}{\sqrt{2}}$ 

$$f'(z) = \text{Cos}z \Rightarrow f'\left(\frac{\pi}{4}\right) = \frac{1}{\sqrt{2}}$$

$$f''(z) = -\text{Sin}z \Rightarrow f''\left(\frac{\pi}{4}\right) = -\frac{1}{\sqrt{2}}$$

$$f'''(z) = -\text{Cos}z \Rightarrow f'''\left(\frac{\pi}{4}\right) = -\frac{1}{\sqrt{2}}$$

Continuing in this .....

Using Taylor's series  $f(z) = \sum_{n=0}^{\infty} \frac{f^n(z_0)}{n!} (z - z_0)^n = \sum_{n=0}^{\infty} \frac{f^n\left(\frac{\pi}{4}\right)}{n!} \left(z - \frac{\pi}{4}\right)^n$ 

$$f(z) = \text{Sin}z = \frac{1}{\sqrt{2}} + \frac{1}{\sqrt{2}} \left(z - \frac{\pi}{4}\right) - \frac{1}{2\sqrt{2}} \left(z - \frac{\pi}{4}\right)^2 \dots \text{Required series.}$$

**Exercise 43: (visit @ Youtube “learning with Usman Hamid”)**

- i. Expand  $f(z) = \log(1 + z^2)$  using Taylor's series when  $z_0 = 1$  and prove that it can be written as  $\log(1 + z^2) = a_0 + \sum_{n=1}^{\infty} a_n(z - 1)^n$  and calculate  $a_0, a_n$
- ii. Expand  $f(z) = \log(1 + z)$  using Taylor's series when  $z_0 = 0$  and find the region of convergence.
- iii. Expand  $f(z) = \frac{1}{z^2}$  using Taylor's series when  $z_0 = 0$
- iv. Expand  $f(z) = \log(z)$  using Taylor's series when  $z_0 = -1 + i$  and find the radius of convergence.
- v. Expand  $f(z) = (1 + i)z^2 - 2z + 4i$  using Taylor's series when  $z_0 = 1 - i$
- vi. Expand  $f(z) = \operatorname{Sinhz}$  using Taylor's series when  $z_0 = \pi i$
- vii. Expand  $f(z) = \operatorname{Cosz}$  using Taylor's series when  $z_0 = \frac{\pi}{2}$
- viii. Expand  $f(z) = \frac{1}{z-4}$  using Taylor's series when  $z_0 = 3$
- ix. Obtain the Taylor's Series  $e^z = e \sum_{n=0}^{\infty} \frac{(z-1)^n}{n!}$  ( $|z - 1| < \infty$ )
- x. Show that  $\frac{1}{z^2} = \frac{1}{4} \sum_{n=0}^{\infty} (-1)^n (n + 1) \left(\frac{z-2}{2}\right)^n$  ( $|z - 2| < 2$ )

**LAURENT SERIES**

If a function  $f$  fails to be analytic at a point  $z_0$ , one cannot apply Taylor's theorem at that point. It is often possible, however, to find a series representation for  $f(z)$  involving both positive and negative powers of  $(z - z_0)$ . We now present the theory of such representations, and we begin with **Laurent's theorem**.

**Theorem:**

Suppose that a function  $f$  is analytic throughout an annular domain  $r < |z - z_0| < R$ , centered at  $z_0$ , and let  $C$  denote any positively oriented simple closed contour around  $z_0$  and lying in that domain (Fig). Then, at each point in the domain,  $f(z)$  has the series representation

$$f(z) = \sum_{n=0}^{\infty} a_n(z - z_0)^n + \sum_{n=1}^{\infty} \frac{b_n}{(z - z_0)^n}$$

Where  $a_n = \frac{1}{2\pi i} \int_C \frac{f(z)}{(z - z_0)^{n+1}} dz$  and  $b_n = \frac{1}{2\pi i} \int_C \frac{f(z)}{(z - z_0)^{-n+1}} dz$

For  $n = 0, 1, 2, 3, \dots, \infty$

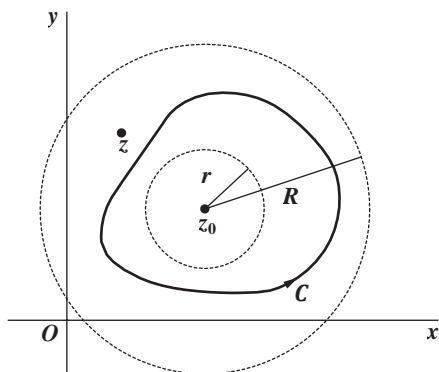

**PROOF:**

Let  $C_1$  and  $C_2$  be two concentric circles forming the annular domain  $D$  such that  $r < |z - z_0| < R$  then suppose that  $z = z_0 + h$  is a point in this annular domain  $D$  so  $f$  is analytic in this annular domain. So by using C. I. Formula

$$f(z_0 + h) = \frac{1}{2\pi i} \int_C \frac{f(z)}{z - (z_0 + h)} dz = \frac{1}{2\pi i} \int_{C_2} \frac{f(z)}{z - (z_0 + h)} dz - \frac{1}{2\pi i} \int_{C_1} \frac{f(z)}{z - (z_0 + h)} dz$$

$$f(z_0 + h) = I_1 + I_2 \dots \dots \dots (A)$$

Now let  $I_1 = \frac{1}{2\pi i} \int_{C_2} \frac{f(z)}{(z - z_0) - h} dz$

$$I_1 = \frac{1}{2\pi i} \int_{C_2} \frac{f(z)}{(z - z_0) \left[1 - \frac{h}{z - z_0}\right]} dz$$

$$I_1 = \frac{1}{2\pi i} \int_{C_2} \frac{f(z)}{(z - z_0)} \left[1 - \frac{h}{z - z_0}\right]^{-1} dz \dots \dots \dots (i)$$

Consider

$$\left[1 - \frac{h}{z-z_0}\right]^{-1} = 1 + \frac{h}{z-z_0} + \frac{h^2}{(z-z_0)^2} + \dots + \frac{h^n}{(z-z_0)^n} + \frac{h^{n+1}}{(z-z_0)^{n+1}} + \dots$$

$$\left[1 - \frac{h}{z-z_0}\right]^{-1} = 1 + \frac{h}{z-z_0} + \frac{h^2}{(z-z_0)^2} + \dots + \frac{h^n}{(z-z_0)^n} + \frac{h^{n+1}}{(z-z_0)^{n+1}} \left[1 + \frac{h}{z-z_0} + \frac{h^2}{(z-z_0)^2} + \dots\right] \dots$$

$$\left[1 - \frac{h}{z-z_0}\right]^{-1} = 1 + \frac{h}{z-z_0} + \frac{h^2}{(z-z_0)^2} + \dots + \frac{h^n}{(z-z_0)^n} + \frac{h^{n+1}}{(z-z_0)^{n+1}} \left[1 - \frac{h}{z-z_0}\right]^{-1}$$

$$\left[1 - \frac{h}{z-z_0}\right]^{-1} = 1 + \frac{h}{z-z_0} + \frac{h^2}{(z-z_0)^2} + \dots + \frac{h^n}{(z-z_0)^n} + \frac{h^{n+1}}{(z-z_0)^{n+1}} \left[\frac{z-z_0-h}{z-z_0}\right]^{-1}$$

$$\left[1 - \frac{h}{z-z_0}\right]^{-1} = 1 + \frac{h}{z-z_0} + \frac{h^2}{(z-z_0)^2} + \dots + \frac{h^n}{(z-z_0)^n} + \frac{h^{n+1}(z-z_0)}{(z-z_0)^{n+1}(z-z_0-h)}$$

$$\left[1 - \frac{h}{z-z_0}\right]^{-1} = 1 + \frac{h}{z-z_0} + \frac{h^2}{(z-z_0)^2} + \dots + \frac{h^n}{(z-z_0)^n} + \frac{h^{n+1}}{(z-z_0)^n(z-z_0-h)} \dots \dots \dots \text{(ii)}$$

$$(i) \Rightarrow I_1 = \frac{1}{2\pi i} \int_C \frac{f(z)}{(z-z_0)} \left[1 + \frac{h}{z-z_0} + \frac{h^2}{(z-z_0)^2} + \dots + \frac{h^n}{(z-z_0)^n} + \frac{h^{n+1}}{(z-z_0)^n(z-z_0-h)}\right] dz$$

$$\Rightarrow I_1 = \frac{1}{2\pi i} \int_{C_2} \frac{f(z)}{(z-z_0)} dz + \frac{h}{2\pi i} \int_{C_2} \frac{f(z)}{(z-z_0)^2} dz + \frac{h^2}{2\pi i} \int_{C_2} \frac{f(z)}{(z-z_0)^3} dz + \dots + \frac{h^n}{2\pi i} \int_{C_2} \frac{f(z)}{(z-z_0)^{n+1}} dz + \frac{h^{n+1}}{2\pi i} \int_{C_2} \frac{f(z)}{(z-z_0)^{n+1}(z-z_0-h)} dz$$

$$I_1 = f(z_0) + \frac{h}{1!} f'(z_0) + \frac{h^2}{2!} f''(z_0) + \dots + \frac{h^n}{n!} f^n(z_0) + R_n \dots \dots \dots \text{(iii)}$$

Where  $R_n = \frac{h^{n+1}}{2\pi i} \int_{C_2} \frac{f(z)}{(z-z_0)^{n+1}(z-z_0-h)} dz$

Now we will prove  $R_n \rightarrow 0$  as  $n \rightarrow \infty$

$$\Rightarrow |R_n| = \left| \frac{h^{n+1}}{2\pi i} \int_{C_2} \frac{f(z)}{(z-z_0)^{n+1}(z-z_0-h)} dz \right|$$

$$\Rightarrow |R_n| \leq \frac{h^{n+1}}{2\pi|i|} \int_{C_2} \frac{|f(z)|}{|z-z_0-h|} \frac{|dz|}{|z-z_0|^{n+1}} < \frac{h^{n+1}}{2\pi|i|} \frac{M}{R^{n+1}} \int_{C_2} |dz|$$

$$\Rightarrow |R_n| < \frac{h^{n+1}}{2\pi|i|} \frac{M}{R^{n+1}} (2\pi R) = Mh \left(\frac{h}{R}\right)^n \Rightarrow |R_n| < Mh \left(\frac{h}{R}\right)^n \rightarrow 0 \text{ as } n \rightarrow \infty$$

Then equation (iii) becomes

$$I_1 = f(z_0) + \frac{h}{1!} f'(z_0) + \frac{h^2}{2!} f''(z_0) + \dots \dots \dots + \frac{h^n}{n!} f^n(z_0)$$

$$I_1 = \sum_{n=0}^{\infty} \frac{f^n(z_0)}{n!} (z-z_0)^n \quad \text{with } z-z_0 = h$$

$$I_1 = \sum_{n=0}^{\infty} a_n (z-z_0)^n \quad \text{with } a_n = \frac{f^n(z_0)}{n!}$$

Now consider  $I_2 = \frac{-1}{2\pi i} \int_{C_1} \frac{f(z)}{z-(z_0+h)} dz = \frac{1}{2\pi i} \int_{C_1} \frac{f(z)}{z_0-z+h} dz$

$$I_2 = \frac{1}{2\pi i} \int_{C_1} \frac{f(z)}{h \left[1 - \frac{z-z_0}{h}\right]} dz$$

$$I_2 = \frac{1}{2\pi i} \int_{C_1} \frac{f(z)}{h} \left[1 - \frac{z-z_0}{h}\right]^{-1} dz \dots \dots \dots \text{(iv)}$$

Consider

$$\begin{aligned} \left[1 - \frac{z-z_0}{h}\right]^{-1} &= 1 + \frac{z-z_0}{h} + \frac{(z-z_0)^2}{h^2} + \dots + \frac{(z-z_0)^n}{h^n} + \frac{(z-z_0)^{n+1}}{h^{n+1}} + \dots \\ \left[1 - \frac{z-z_0}{h}\right]^{-1} &= 1 + \frac{z-z_0}{h} + \frac{(z-z_0)^2}{h^2} + \dots + \frac{(z-z_0)^n}{h^n} + \frac{(z-z_0)^{n+1}}{h^{n+1}} \left[1 + \frac{z-z_0}{h} + \frac{(z-z_0)^2}{h^2} + \dots\right] \dots \\ \left[1 - \frac{z-z_0}{h}\right]^{-1} &= 1 + \frac{z-z_0}{h} + \frac{(z-z_0)^2}{h^2} + \dots + \frac{(z-z_0)^n}{h^n} + \frac{(z-z_0)^{n+1}}{h^{n+1}} \left[1 - \frac{z-z_0}{h}\right]^{-1} \\ \left[1 - \frac{z-z_0}{h}\right]^{-1} &= 1 + \frac{z-z_0}{h} + \frac{(z-z_0)^2}{h^2} + \dots + \frac{(z-z_0)^n}{h^n} + \frac{(z-z_0)^{n+1}}{h^{n+1}} \left[\frac{h-z+z_0}{h}\right]^{-1} \\ \left[1 - \frac{z-z_0}{h}\right]^{-1} &= 1 + \frac{z-z_0}{h} + \frac{(z-z_0)^2}{h^2} + \dots + \frac{(z-z_0)^n}{h^n} + \frac{(z-z_0)^{n+1}}{h^n(h-z+z_0)} \dots \dots \dots (v) \end{aligned}$$

$$\begin{aligned} (iv) \Rightarrow I_1 &= \frac{1}{2\pi i} \int_{C_1} \frac{f(z)}{h} \left[1 + \frac{z-z_0}{h} + \frac{(z-z_0)^2}{h^2} + \dots + \frac{(z-z_0)^n}{h^n} + \frac{(z-z_0)^{n+1}}{h^n(h-z+z_0)}\right] dz \\ &\Rightarrow I_2 = \\ &\frac{1}{2\pi i h} \int_{C_1} f(z) dz + \frac{1}{2\pi i h^2} \int_{C_1} f(z)(z-z_0)^2 dz + \frac{1}{2\pi i h^3} \int_{C_1} f(z)(z-z_0)^3 dz + \\ &\dots + \frac{1}{2\pi i h^n} \int_{C_1} f(z)(z-z_0)^n dz + \frac{1}{2\pi i h^{n+1}} \int_{C_1} \frac{f(z)(z-z_0)^{n+1}}{(h-z+z_0)} dz \end{aligned}$$

$$\begin{aligned} \Rightarrow I_2 &= \\ \frac{1}{h} &\left[ \frac{1}{2\pi i} \int_{C_1} \frac{f(z)}{(z-z_0)^{-1+1}} dz \right] + \frac{1}{h^2} \left[ \frac{1}{2\pi i} \int_{C_1} \frac{f(z)}{(z-z_0)^{-2+1}} dz \right] + \frac{1}{h^3} \left[ \frac{1}{2\pi i} \int_{C_1} \frac{f(z)}{(z-z_0)^{-3+1}} dz \right] + \\ &\dots + \frac{1}{h^n} \left[ \frac{1}{2\pi i} \int_{C_1} \frac{f(z)}{(z-z_0)^{-n+1}} dz \right] + \frac{-1}{2\pi i h^{n+1}} \int_{C_1} \frac{f(z)(z-z_0)^{n+1}}{z-(z_0+h)} dz \\ I_2 &= \frac{1}{h} b_1 + \frac{1}{h^2} b_2 + \frac{1}{h^3} b_3 + \dots + \frac{1}{h^n} b_n + R_n \dots \dots \dots (vi) \end{aligned}$$

Where 
$$R_n = \frac{-1}{2\pi i h^{n+1}} \int_{C_1} \frac{f(z)(z-z_0)^{n+1}}{z-(z_0+h)} dz$$

Now we will prove  $R_n \rightarrow 0$  as  $n \rightarrow \infty$

$$\begin{aligned} \Rightarrow |R_n| &= \left| \frac{-1}{2\pi i h^{n+1}} \int_{C_1} \frac{f(z)(z-z_0)^{n+1}}{z-(z_0+h)} dz \right| \\ \Rightarrow |R_n| &\leq \frac{1}{2\pi |i| h^{n+1}} \int_{C_1} \left| \frac{f(z)}{z-(z_0+h)} \right| |z-z_0|^{n+1} |dz| < \frac{1}{2\pi h^{n+1}} M r^{n+1} \int_{C_1} |dz| \\ \Rightarrow |R_n| &< \frac{1}{2\pi h^{n+1}} M r^{n+1} (2\pi r) = M r \left(\frac{r}{h}\right)^n \\ \Rightarrow |R_n| &< M r \left(\frac{r}{h}\right)^n \rightarrow 0 \text{ as } n \rightarrow \infty \end{aligned}$$

Then equation (vi) becomes

$$\begin{aligned} I_2 &= \frac{1}{h} b_1 + \frac{1}{h^2} b_2 + \frac{1}{h^3} b_3 + \dots + \frac{1}{h^n} b_n \\ I_2 &= \sum_{n=1}^{\infty} \frac{1}{h^n} b_n \Rightarrow I_1 = \sum_{n=1}^{\infty} \frac{b_n}{(z-z_0)^n} \end{aligned}$$

Using both values in (A) we get the required

$$f(z) = \sum_{n=0}^{\infty} a_n (z-z_0)^n + \sum_{n=1}^{\infty} \frac{b_n}{(z-z_0)^n}$$



**Remark:**

- **Uniqueness property of Laurent's Theorem:**  
suppose  $f(z) = \sum_{n=-\infty}^{\infty} a_n(z - z_0)^n$  ;  $r < |z - z_0| < R$  then the series is necessarily identical with the Laurent's Series for  $f(z)$
- **Uniqueness property of Taylor's Theorem:**  
suppose  $f(z) = \sum_{n=0}^{\infty} a_n(z - z_0)^n$  ;  $r < |z - z_0| < R$  then the series is necessarily identical with the Taylor's Series for  $f(z)$
- Suppose that  $f(z) = \sum_{n=-\infty}^{\infty} a_n z^n$  and  $g(z) = \sum_{n=-\infty}^{\infty} b_n z^n$  be two Laurent's Series expansions which converges in the same annulus then their Product  $f(z) \cdot g(z)$  also converges and represents the Laurent's Series expansion.
- If  $z$  replace by  $\frac{1}{z}$  in a given function  $f(z)$  then  $f(z)$  does not change.  
Then we have  $a_n = b_n = a_{-n}$
- Finding Laurent's Series if condition appears in the form  $|z - z_0| < R$  then take constant as common and no need to take variable in most cases while if condition appears in the form  $|z - z_0| > R$  then take variable as common necessarily from denominator.

**Example:**

Show that  $f(z) = \frac{1}{4z - z^2} = \sum_{n=0}^{\infty} \frac{z^{n-1}}{4^{n+1}}$  when  $0 < |z| < 4$

**Solution:**

$$\text{Given that } f(z) = \frac{1}{4z - z^2} = \frac{1}{4z \left[1 - \frac{z}{4}\right]} = \frac{1}{4z} \left[1 - \frac{z}{4}\right]^{-1}$$

$$f(z) = \frac{1}{4z - z^2} = \frac{1}{4z} \left[1 + \frac{z}{4} + \frac{z^2}{4^2} + \frac{z^3}{4^3} + \dots\right]$$

$$f(z) = \frac{1}{4z - z^2} = \left[\frac{1}{4z} + \frac{1}{4z} \cdot \frac{z}{4} + \frac{1}{4z} \cdot \frac{z^2}{4^2} + \frac{1}{4z} \cdot \frac{z^3}{4^3} + \dots\right]$$

$$f(z) = \frac{1}{4z - z^2} = \frac{1}{4z} + \frac{1}{4^2} + \frac{z^1}{4^3} + \frac{z^2}{4^4} + \dots$$

$$f(z) = \frac{1}{4z - z^2} = \frac{z^{-1}}{4} + \frac{z^0}{4^2} + \frac{z^1}{4^3} + \frac{z^2}{4^4} + \dots$$

$$f(z) = \frac{1}{4z - z^2} = \frac{z^{0-1}}{4^{0+1}} + \frac{z^{-1+1}}{4^{1+1}} + \frac{z^{2-1}}{4^{2+1}} + \frac{z^{3-1}}{4^{3+1}} + \dots$$

$$\text{Thus } f(z) = \frac{1}{4z - z^2} = \sum_{n=0}^{\infty} \frac{z^{n-1}}{4^{n+1}} \text{ when } 0 < |z| < 4$$

**Exercise 44: (visit @ Youtube “learning with Usman Hamid”)**

1. For the function  $f(z) = \frac{1}{z(1+z^2)}$  find the Laurent's series representation in the punctured disk  $0 < |z| < 1$
2. For the function  $f(z) = \frac{1}{z(z-1)}$  find the Laurent's series representation in the punctured disk  $1 < |z-2| < 2$
3. For the function  $f(z) = \frac{-1}{(z-1)(z-2)}$  find the Laurent's series representation in the regions  $1 < |z| < 2$
4. Find a representation for the function  $f(z) = \frac{z+1}{z-1}$  when  $D: |z| < 1$
5. Show that  $\frac{z}{(z-1)(z-3)} = -3 \sum_{n=0}^{\infty} \frac{(z-1)^n}{2^{n+2}} - \frac{1}{2(z-1)}$  when  $0 < |z-1| < 2$
6. For the function  $f(z) = \frac{1}{(z+1)(z+3)}$  find the Laurent's series representation in the regions  $|z| < 1$ ,  $1 < |z| < 3$ ,  $|z| > 3$  and  $0 < |z+1| < 2$
7. For the function  $f(z) = \frac{1}{(z+2)(1+z^2)}$  find the Laurent's series representation in the regions  $|z| < 1$ ,  $1 < |z| < 2$ ,  $|z| > 2$
8. For the function  $f(z) = \frac{1}{(z^2+1)(z^2+2)}$  find the Laurent's series representation in the regions  $|z| < 1$ ,  $1 < |z| < \sqrt{2}$ ,  $|z| > \sqrt{2}$
9. For the function  $f(z) = \frac{1}{z^2-z-2}$  find the Laurent's series representation in the region  $1 < |z| < 2$
10. Prove that the Laurent's Series expansion of  $f(z) = \frac{1}{z-h}$  for region  $|z| > |h|$  is given by  $\sum_{n=0}^{\infty} \frac{h^n}{z^{n+1}}$
11. Show that Laurent's series is the power of  $z+1$  which represents the function  $f(z) = \frac{z^2+1}{z(z^2-3z+2)}$  in the region  $|z+1| > 3$  is  $f(z) = \frac{1}{2} \sum_{n=0}^{\infty} (1 - 2^{n+2} + 5 \cdot 3^n)(z+1)^{-(n+1)}$
12. Expand  $f(z) = \frac{1}{z(z-1)}$  for the annular domain  $1 < |z-1|$
13. Expand  $f(z) = \frac{8z+1}{z(1-z)}$  for the domain  $0 < |z| < 1$

**Example:**

For the function  $f(z) = \frac{z+1}{z-1}$  find the Laurent's series representation in the punctured disk  $0 < |z| < \infty$

**Solution:**

Given function  $f(z) = \frac{z+1}{z-1}$  has the singular point  $z = 1$  and analytic in the given domain and The representation of  $f(z)$  in the unbounded domain  $0 < |z| < \infty$  is a Laurent Series and the fact that  $\left|\frac{1}{z}\right| < 1$  when 'z' is a point in given domain then replacing 'z' with '1/z'

$$f(z) = \frac{z+1}{z-1} = -\frac{1+\frac{1}{z}}{1-\frac{1}{z}} = -\left(1 + \frac{1}{z}\right) \frac{1}{1-\frac{1}{z}} = -\left(1 + \frac{1}{z}\right) \sum_{n=0}^{\infty} \frac{1}{z^n}$$

$$f(z) = \left(1 + \frac{1}{z}\right) \sum_{n=0}^{\infty} \frac{1}{z^n} = \sum_{n=0}^{\infty} \frac{1}{z^n} + \sum_{n=0}^{\infty} \frac{1}{z^{n+1}} \quad \text{since } a_n = b_n = a_{-n}$$

$$f(z) = \sum_{n=0}^{\infty} \frac{1}{z^n} + \sum_{n=1}^{\infty} \frac{1}{z^n} = 1 + 2 \sum_{n=1}^{\infty} \frac{1}{z^n} \quad \text{for 'n-1' in place of 'n'}$$

**Exercise 45: (visit @ Youtube "learning with Usman Hamid")**

1. For the function  $f(z) = \frac{1}{z(1+z^2)}$  find the Laurent's series representation in the region  $1 < |z| < \infty$
2. For the function  $f(z) = z^2 \sin\left(\frac{1}{z^2}\right)$  find the Laurent's series representation in the domain  $0 < |z| < \infty$
3. For the function  $f(z) = \frac{-1}{(z-1)(z-2)}$  find the Laurent's series representation in the region  $2 < |z| < \infty$
4. For the function  $f(z) = \frac{1}{z^2(1-z)}$  find the Laurent's series representation in the region  $1 < |z| < \infty$
5. Find a representation for the function  $f(z) = \frac{1}{1+z} = \frac{1}{z} \cdot \frac{1}{1+\frac{1}{z}}$  in negative powers of 'z' that is valid when  $1 < |z| < \infty$
6. Show that  $f(z) = e^{1/z} = \sum_{n=0}^{\infty} \frac{1}{n!z^n}$  when  $0 < |z| < \infty$
7. Show that  $\frac{1}{z^2} = \sum_{n=2}^{\infty} \frac{(-1)^n(n-1)}{(z-1)^n}$  when  $1 < |z-1| < \infty$
8. Given series expansion  $\text{Sin}z = \sum_{n=0}^{\infty} (-1)^{n+1} \frac{z^{2n-1}}{(2n-1)!}$  for  $|z| < \infty$  then find the 1<sup>st</sup> three non – negative terms of the Laurent's Series expansion of Cosecz about point  $z = 0$ .
9. Expand  $f(z) = e^{3z}$  for the domain  $0 < |z| < \infty$

**Example:**

Show that  $f(z) = \cos\left(z + \frac{1}{z}\right)$  can be expanded as a Laurent's Series

$$f(z) = a_0 + \sum_{n=1}^{\infty} a_n \left(z^n + \frac{1}{z^n}\right) \text{ where } a_n = \frac{1}{2\pi} \int_0^{2\pi} \cos(2\cos\theta) \cos n\theta d\theta$$

**Solution:** Given that  $f(z) = \cos\left(z + \frac{1}{z}\right)$  and  $f$  is non-analytic at  $z = 0$

$$\text{Put } z = \frac{1}{z} \text{ in given function then } f(z) = \cos\left(\frac{1}{z} + z\right) = \cos\left(z + \frac{1}{z}\right)$$

$$f(z) = f\left(\frac{1}{z}\right) \Rightarrow a_n = b_n \text{ since } b_n = a_{-n}$$

then Laurent's Series will be expanded as

$$f(z) = \sum_{n=-\infty}^{\infty} a_n (z - z_0)^n$$

$$f(z) = \sum_{n=-\infty}^{\infty} a_n z^n \text{ for } z_0 = 0$$

$$f(z) = a_0 + a_1 z^1 + a_{-1} z^{-1} + a_2 z^2 + a_{-2} z^{-2} + \dots$$

$$f(z) = a_0 + a_1 z^1 + \frac{a_{-1}}{z^1} + a_2 z^2 + \frac{a_{-2}}{z^2} + \dots$$

$$f(z) = a_0 + \sum_{n=1}^{\infty} a_n z^n + \frac{a_{-n}}{z^n} = a_0 + \sum_{n=1}^{\infty} a_n z^n + \frac{a_n}{z^n} \quad \therefore a_n = b_n = a_{-n}$$

$$f(z) = a_0 + \sum_{n=1}^{\infty} a_n \left(z^n + \frac{1}{z^n}\right)$$

Now we will find  $a_n$

$$\text{Since we know that } a_n = \frac{1}{2\pi i} \int_C \frac{f(z)}{(z - z_0)^{n+1}} dz$$

$$\Rightarrow a_n = \frac{1}{2\pi i} \int_C \frac{\cos\left(z + \frac{1}{z}\right)}{(z - 0)^{n+1}} dz \Rightarrow a_n = \frac{1}{2\pi i} \int_C \frac{\cos\left(z + \frac{1}{z}\right)}{z^{n+1}} dz \quad \dots\dots\dots(i)$$

Put

$$z = e^{i\theta}, \frac{1}{z} = e^{-i\theta} \Rightarrow z + \frac{1}{z} = e^{i\theta} + e^{-i\theta} = 2\cos\theta, dz = ie^{i\theta} d\theta; 0 < \theta < 2\pi$$

$$(i) \Rightarrow a_n = \frac{1}{2\pi i} \int_0^{2\pi} \frac{\cos(2\cos\theta)}{(e^{i\theta})^{n+1}} (ie^{i\theta} d\theta) = \frac{1}{2\pi} \int_0^{2\pi} \cos(2\cos\theta) e^{-ni\theta} d\theta$$

$$\Rightarrow a_n = \frac{1}{2\pi} \int_0^{2\pi} \cos(2\cos\theta) (\cos n\theta - i\sin n\theta) d\theta$$

$$\Rightarrow a_n = \frac{1}{2\pi} \int_0^{2\pi} \cos(2\cos\theta) \cos n\theta d\theta - \frac{i}{2\pi} \int_0^{2\pi} \cos(2\cos\theta) \sin n\theta d\theta$$

$$\Rightarrow a_n = \frac{1}{2\pi} \int_0^{2\pi} \cos(2\cos\theta) \cos n\theta d\theta - \frac{i}{2\pi} I \quad \dots\dots\dots(ii)$$

To get required value of  $a_n$  we just show  $I = 0$

$$\text{Let } I = \int_0^{2\pi} \cos(2\cos\theta) \sin n\theta d\theta$$

$$I = \int_0^{2\pi} \cos[2\cos(2\pi - \theta)] \sin n(2\pi - \theta) d\theta \quad \therefore \int_0^a f(z) dz = \int_0^a f(a - z) dz$$

$$I = \int_0^{2\pi} \cos[2\cos(2\pi - \theta)] \sin(2n\pi - n\theta) d\theta$$

$$I = \int_0^{2\pi} \cos(2\cos\theta) (-\sin n\theta) d\theta = - \int_0^{2\pi} \cos(2\cos\theta) \sin n\theta d\theta = -I$$

$$I + I = 2I = 0 \Rightarrow I = 0$$

$$(ii) \Rightarrow a_n = \frac{1}{2\pi} \int_0^{2\pi} \cos(2\cos\theta) \cos n\theta d\theta \text{ which is our required.}$$

**Exercise 46: (visit @ Youtube “learning with Usman Hamid”)**

1. Show that  $f(z) = e^{uz + \frac{v}{z}}$  can be expand as a Laurent's Series  
 $f(z) = a_0 + \sum_{n=1}^{\infty} a_n z^n + \frac{b_n}{z^n}$  determine  $a_n$  and  $b_n$
2. Show that  $f(z) = e^{c(z + \frac{1}{z})}$  can be expand as a Laurent's Series  
 $f(z) = \sum_{n=0}^{\infty} a_n z^n + \sum_{n=1}^{\infty} \frac{b_n}{z^n}$  for  $|z| > 0$  where  
 $a_n = \frac{1}{2\pi} \int_0^{2\pi} e^{2c \cos \theta} \cos n\theta d\theta$
3. Show that  $f(z) = \cos\left(c\left(z + \frac{1}{z}\right)\right) = \sum_{n=-\infty}^{\infty} a_n z^n$   
 where  $a_n = \frac{1}{2\pi} \int_0^{2\pi} \cosh(2c \cos \theta) \cos n\theta d\theta$  when  $z \neq 0$
4. Show that  $f(z) = e^{\frac{k}{2}\left(z - \frac{1}{z}\right)} = \sum_{n=-\infty}^{\infty} a_n z^n$   
 where  $a_n = \int_0^{2\pi} \cos(n\theta - k \sin \theta) d\theta$
5. Prove that the Laurent's Series of  $f(z) = \frac{1}{e^z - 1}$  about  $z_0 = 0$  is of the  
 form  $f(z) = \sum_{n=0}^{\infty} \frac{B_n}{n!} z^{n-1}$   
 where  $B_0 = 1, B_1 = -\frac{1}{2}, B_2 = \frac{1}{6}, B_3 = 0, B_4 = -\frac{136}{30}$   
 while numbers  $B_n$  are called Bernolli Numbers.
6. Find the Principle Part of the Laurent's Series of;
  - i.  $f(z) = \frac{e^z + 1}{e^z - 1}$  about  $z_0 = 2\pi i$
  - ii.  $f(z) = \cot \pi z$  about  $z_0 = n$  (arbitrary)

---

**RESIDUES AND POLES**

The Cauchy–Goursat theorem states that if a function is analytic at all points interior to and on a simple closed contour  $C$ , then the value of the integral of the function around that contour is zero. If, however, the function fails to be analytic at a finite number of points interior to  $C$ , there is, as we shall see in this chapter, a specific number, called a **residue**, which each of those points contributes to the value of the integral. We develop here the theory of residues; and, in next Chapter we shall illustrate their use in certain areas of applied mathematics.

**ISOLATED SINGULAR POINTS**

Recall that a point  $z_0$  is called a **singular point** of a function  $f$  if  $f$  fails to be analytic at  $z_0$  but is analytic at some point in every neighborhood of  $z_0$ .

A singular point  $z_0$  is said to be **isolated** if, there is a deleted neighborhood  $0 < |z - z_0| < \varepsilon$  of  $z_0$  throughout which  $f$  is analytic.

**Example:** The function  $f(z) = \frac{z-1}{z^5(z^2+9)}$  has the three isolated singular points  $z = 0$  and  $z = \pm 3i$ .

**Example:** The function  $f(z) = \frac{1}{\sin(\frac{\pi}{z})}$  has the singular points  $z = 0$  and  $z = 1/n$  ( $n = 1, 2, \dots$ ). Each singular point except  $z = 0$  is isolated. The singular point  $z = 0$  is not isolated because every deleted  $\varepsilon$  neighborhood of the origin contains other singular points of the function.

More precisely, when a positive number  $\varepsilon$  is specified and  $m$  is any positive integer such that  $m > 1/\varepsilon$ , the fact that  $0 < 1/m < \varepsilon$  means that the point  $z = 1/m$  lies in the deleted  $\varepsilon$  neighborhood  $0 < |z| < \varepsilon$  (Fig).

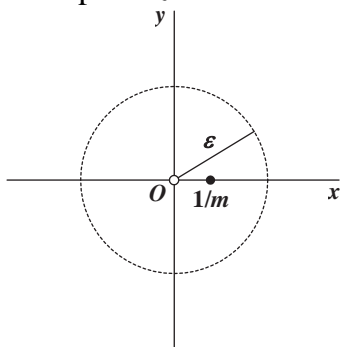

**Example:**

The origin  $z = 0$  is a singular point of the principal branch

$\text{Log } z = \ln r + i\theta \quad (r > 0, -\pi < \theta < \pi)$  of the logarithmic function. It is *not*,

however, an isolated singular point since every deleted  $\varepsilon$  neighborhood of it contains points on the negative real axis (see Fig) and the branch is not even

defined there. Similar remarks can be made regarding any branch

$\log z = \ln r + i\theta \quad (r > 0, \alpha < \theta < \alpha + 2\pi)$  of the logarithmic function.

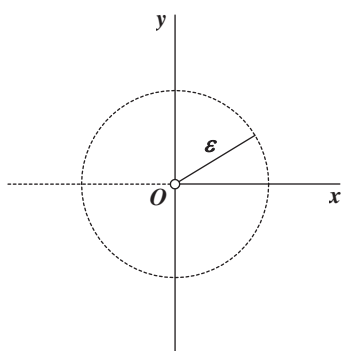

In this chapter, it will be important to keep in mind that if a function is analytic everywhere inside a simple closed contour  $C$  except for a *finite* number of singular points  $z_1, z_2, \dots, z_n$ , those points must all be isolated and the deleted neighborhoods about them can be made small enough to lie entirely inside  $C$ . To see that this is so, consider any one of the points  $z_k$ . The radius  $\varepsilon$  of the needed deleted neighborhood can be any positive number that is smaller than the distances to the other singular points and also smaller than the distance from  $z_k$  to the closest point on  $C$ .

Finally, we mention that it is sometimes convenient to consider the point at infinity as an isolated singular point. To be specific, if there is a positive number  $R_1$  such that  $f$  is analytic for  $R_1 < |z| < \infty$ , then  $f$  is said to have an *isolated singular point* at  $z_0 = \infty$ .

## RESIDUES

When  $z_0$  is an isolated singular point of a function  $f$ , there is a positive number  $R_2$  such that  $f$  is analytic at each point  $z$  for which  $0 < |z - z_0| < R_2$ . Consequently,  $f(z)$  has a Laurent series representation  $f(z) = \sum_{n=0}^{\infty} a_n(z - z_0)^n + \frac{b_1}{z - z_0} + \frac{b_2}{(z - z_0)^2} + \dots + \frac{b_n}{(z - z_0)^n} + \dots$  where the coefficients  $a_n$  and  $b_n$  have certain integral representations.

In particular,

$$b_n = \frac{1}{2\pi i} \int_C \frac{f(z)}{(z - z_0)^{-n+1}} dz \quad (n=1,2,3,\dots)$$

where  $C$  is any positively oriented simple closed contour around  $z_0$  that lies in the punctured disk  $0 < |z - z_0| < R_2$  (Fig). When  $n=1$ , this expression for  $b_n$  becomes

$$b_1 = \frac{1}{2\pi i} \int_C f(z) dz \Rightarrow \int_C f(z) dz = 2\pi i b_1$$

The complex number  $b_1$ , which is the coefficient of  $\frac{1}{(z - z_0)}$  in above expansion, is called the **residue** of  $f$  at the isolated singular point  $z_0$ , and we shall often write  $b_1 = \text{Res}_{z=z_0} f(z)$

Then  $\Rightarrow \int_C f(z) dz = 2\pi i \text{Res}_{z=z_0} f(z)$

Sometimes we simply use  $B$  to denote the residue when the function  $f$  and the point  $z_0$  are clearly indicated. Last Equation provides a powerful method for evaluating certain integrals around simple closed contours.

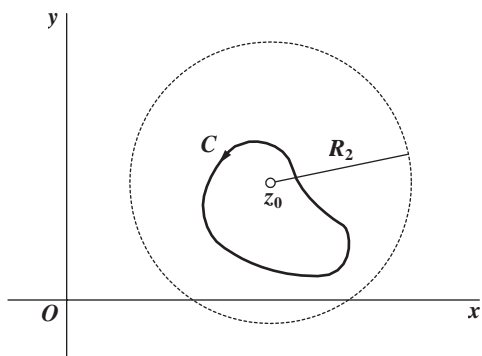

**DEFINITION:** If a function  $f$  has an isolated singularity at a point  $z = z_0$  then  $f$  has Laurent's expansion as follows;

$$f(z) = \sum_{n=0}^{\infty} a_n(z - z_0)^n + \sum_{n=1}^{\infty} \frac{b_n}{(z - z_0)^n}$$

then coefficient  $b_1$  of  $\frac{1}{(z - z_0)}$  is called Residue of a function  $f(z)$  at  $z = z_0$  and it is denoted by

$$b_1 = (f, z_0) \quad \text{or} \quad b_1 = \text{Res}_{z=z_0} f(z)$$



**Example:** Find the residue of  $f(z) = \frac{1}{(z-1)^2(z-3)}$  at  $z = 1$ .

**Solution:** Given  $f(z) = \frac{1}{(z-1)^2(z-3)}$

$$f(z) = \frac{1}{(z-1)^2(z-2-1)} = \frac{1}{(z-1)^2(2-(z-1))} = \frac{-1}{2(z-1)^2\left(1-\frac{(z-1)}{2}\right)}$$

$$f(z) = \frac{-1}{2(z-1)^2} \left(1 - \frac{(z-1)}{2}\right)^{-1}$$

$$f(z) = \frac{-1}{2(z-1)^2} \left(1 + \frac{(z-1)}{2} + \frac{(z-1)^2}{2^2} + \dots\right)$$

$$f(z) = \frac{-1}{2(z-1)^2} + \frac{-1}{4(z-1)} - \frac{1}{8}$$

$$f(z) = \frac{-\frac{1}{2}}{(z-1)^2} + \frac{-\frac{1}{4}}{(z-1)} - \frac{1}{8}$$

This is Laurent Series expansion in  $\left|\frac{z-1}{2}\right| < 1$  or  $0 < |z-1| < 2$  and by

definition of residue  $Res(f, 1) = -\frac{1}{4}$

**Example:** Find the residue of  $f(z) = \frac{1}{\sinh z}$  at  $z = 0$ .

**Solution:** Given  $f(z) = \frac{1}{\sinh z}$

$$f(z) = \frac{1}{z + \frac{z^3}{3!} + \frac{z^5}{5!} + \dots} = \frac{1}{z \left[1 + \left(\frac{z^2}{3!} + \frac{z^4}{5!} + \dots\right)\right]}$$

$$f(z) = \frac{1}{z} \left[1 + \left(\frac{z^2}{3!} + \frac{z^4}{5!} + \dots\right)\right]^{-1}$$

$$f(z) = \frac{1}{z} \left[1 - \left(\frac{z^2}{3!} + \frac{z^4}{5!} + \dots\right) + \dots\right]$$

$$f(z) = \frac{1}{z} + \frac{-z}{3!} + \frac{-z^3}{5!} + \dots$$

This is Laurent's Series expansion at  $z = 0$

Then by definition of residue  $b_1 = (f, 0) = 1$

**Keep in mind:** Pole is a finite order singularity. We will discuss it later.

**THEOREM (Residue of a function at a pole of order 'n')**

If  $f(z)$  has a pole of order 'n' at  $z = z_0$  then

$$\text{Res}(f, z_0) = \frac{1}{(n-1)!} \lim_{z \rightarrow z_0} \frac{d^{n-1}}{dz^{n-1}} [(z - z_0)^n f(z)]$$

**Proof:**

If  $f(z)$  has a pole of order 'n' at  $z = z_0$  then the Laurent's Series expansion will be as follows;

$$f(z) = \sum_{k=0}^{\infty} a_k (z - z_0)^k + \sum_{k=1}^n \frac{b_k}{(z - z_0)^k}$$

$$f(z) = a_0 (z - z_0)^0 + a_1 (z - z_0)^1 + a_2 (z - z_0)^2 + \dots + \frac{b_1}{z - z_0} + \frac{b_2}{(z - z_0)^2} + \dots + \frac{b_n}{(z - z_0)^n}$$

Multiplying both sides by  $(z - z_0)^n$

$$(z - z_0)^n f(z) = a_0 (z - z_0)^n + a_1 (z - z_0)^{n+1} + a_2 (z - z_0)^{n+2} + \dots + b_1 (z - z_0)^{n-1} + b_2 (z - z_0)^{n-2} + \dots + b_n \dots \dots \dots (i)$$

Now differentiating (i) w.r.to 'z' ( $n - 1$  time)

$$\frac{d}{dz} [(z - z_0)^n f(z)] = n a_0 (z - z_0)^{n-1} + (n + 1) a_1 (z - z_0)^n + (n + 2) a_2 (z - z_0)^{n+1} + \dots + (n - 1) b_1 (z - z_0)^{n-2} + (n - 2) b_2 (z - z_0)^{n-3} + \dots + b_{n-1} + 0$$

$$\frac{d^2}{dz^2} [(z - z_0)^n f(z)] = n(n - 1) a_0 (z - z_0)^{n-2} + n(n + 1) a_1 (z - z_0)^{n-1} + (n + 1)(n + 2) a_2 (z - z_0)^n + \dots + (n - 1)(n - 2) b_1 (z - z_0)^{n-3} + (n - 2)(n - 3) b_2 (z - z_0)^{n-4} + \dots + b_{n-2} + 0 + 0$$

Continuing in this manner we get

$$\frac{d^{n-1}}{dz^{n-1}} [(z - z_0)^n f(z)] = [n(n - 1) \dots \dots 3.2.1] a_0 (z - z_0)^{n-(n-1)} + \dots + [(n - 1)(n - 2) \dots \dots 3.2.1] b_1 (z - z_0)^{n-n}$$

$$\frac{d^{n-1}}{dz^{n-1}} [(z - z_0)^n f(z)] = n! a_0 (z - z_0) + (n - 1)! b_1$$

Applying  $\lim_{z \rightarrow z_0}$  on both sides

$$\lim_{z \rightarrow z_0} \frac{d^{n-1}}{dz^{n-1}} [(z - z_0)^n f(z)] = \lim_{z \rightarrow z_0} [n! a_0 (z - z_0) + (n - 1)! b_1]$$

$$\lim_{z \rightarrow z_0} \frac{d^{n-1}}{dz^{n-1}} [(z - z_0)^n f(z)] = 0 + (n - 1)! b_1$$

$$\lim_{z \rightarrow z_0} \frac{d^{n-1}}{dz^{n-1}} [(z - z_0)^n f(z)] = (n - 1)! b_1$$

$$\frac{1}{(n-1)!} \lim_{z \rightarrow z_0} \frac{d^{n-1}}{dz^{n-1}} [(z - z_0)^n f(z)] = b_1 = \text{Res}(f, z_0)$$

Hence we get the result.  $\text{Res}(f, z_0) = \frac{1}{(n-1)!} \lim_{z \rightarrow z_0} \frac{d^{n-1}}{dz^{n-1}} [(z - z_0)^n f(z)]$

**Remark:**

- i. If function has a simple pole at  $z = z_0$  then  

$$\text{Res}(f, z_0) = \lim_{z \rightarrow z_0} [(z - z_0)f(z)]$$
- ii. For a quotient function  $f(z) = \frac{g(z)}{h(z)}$  where 'g' and 'h' are analytic at  $z = z_0$  then  

$$\text{Res}(f, z_0) = \frac{g'(z_0)}{h'(z_0)}$$
- iii. A function which has more than one poles is called **Meromorphic function**.

**Example:** Find the residue of  $f(z) = \frac{z}{z^2+16}$  at all poles.

**Solution:** Given  $f(z) = \frac{z}{z^2+16} = \frac{z}{(z+4i)(z-4i)}$  is a meromorphic function and

has two poles of order 1 (simple poles) at  $z = \pm 4i$

Then by using Residue formula for Simple pole at  $z = z_0$

$$\text{Res}(f, z_0) = \lim_{z \rightarrow z_0} [(z - z_0)f(z)]$$

$$\text{Res}(f, -4i) = \lim_{z \rightarrow -4i} \left[ (z + 4i) \frac{z}{(z+4i)(z-4i)} \right] = \frac{1}{2}$$

$$\text{Res}(f, 4i) = \lim_{z \rightarrow 4i} \left[ (z - 4i) \frac{z}{(z+4i)(z-4i)} \right] = \frac{1}{2}$$

**Example:** Find the residue of  $f(z) = \frac{\cos z}{z^2(z-\pi)}$  at  $z = \pi$

**Solution:** Given  $f(z) = \frac{\cos z}{z^2(z-\pi)}$  has a simple pole at  $z = \pi$

Then by using Residue formula for Simple pole at  $z = z_0$

$$\text{Res}(f, z_0) = \lim_{z \rightarrow z_0} [(z - z_0)f(z)]$$

$$\text{Res}(f, \pi) = \lim_{z \rightarrow \pi} [(z - \pi)f(z)]$$

$$\text{Res}(f, \pi) = \lim_{z \rightarrow \pi} \left[ (z - \pi) \frac{\cos z}{z^2(z-\pi)} \right] = \frac{\cos \pi}{\pi^2}$$

$$\text{Res}(f, \pi) = \frac{-1}{\pi^2}$$

**Example:**

Find the residue of  $f(z) = \frac{e^z}{z^2(z-\pi i)^4}$  at  $z = 0, \pi i$

**Solution:**

Given  $f(z) = \frac{e^z}{z^2(z-\pi i)^4}$  is a meromorphic function and has two poles at  $z = 0$

and  $z = \pi i$

$z = 0$  is a pole of order 2

And

$z = \pi i$  is a pole of order 4

By using formula  $Res(f, z_0) = \frac{1}{(n-1)!} \lim_{z \rightarrow z_0} \frac{d^{n-1}}{dz^{n-1}} [(z - z_0)^n f(z)]$

$$Res(f, 0) = \frac{1}{(2-1)!} \lim_{z \rightarrow 0} \frac{d^{2-1}}{dz^{2-1}} [(z-0)^2 f(z)]$$

$$Res(f, 0) = \frac{1}{1!} \lim_{z \rightarrow 0} \frac{d}{dz} \left[ z^2 \frac{e^z}{z^2(z-\pi i)^4} \right] = \lim_{z \rightarrow 0} \frac{d}{dz} \left[ \frac{e^z}{(z-\pi i)^4} \right]$$

$$Res(f, 0) = \lim_{z \rightarrow 0} \left[ \frac{e^z(z-\pi i-4)}{(z-\pi i)^5} \right] = \frac{\pi-4i}{\pi^5} \quad \text{after solving}$$

$$\text{Also } Res(f, \pi i) = \frac{1}{(4-1)!} \lim_{z \rightarrow \pi i} \frac{d^{4-1}}{dz^{4-1}} [(z-\pi i)^4 f(z)]$$

$$Res(f, \pi i) = \frac{1}{3!} \lim_{z \rightarrow \pi i} \frac{d^3}{dz^3} \left[ (z-\pi i)^4 \frac{e^z}{z^2(z-\pi i)^4} \right]$$

$$Res(f, \pi i) = \frac{1}{6} \lim_{z \rightarrow \pi i} \frac{d^3}{dz^3} \left[ \frac{e^z}{z^2} \right]$$

$$Res(f, \pi i) = \frac{(\pi^3-18\pi)+(6\pi^2-24)i}{6\pi^5} \quad \text{after solving}$$

**Exercise 47: (visit @ Youtube “learning with Usman Hamid”)**

1. Find the residue of  $f(z) = \operatorname{Tanh}z$  by finding its zeros.

2. Find the residue of  $f(z) = \operatorname{Tanz}$  by finding its zeros.

3. Find the residue of the following functions

i.  $f(z) = \frac{z}{z^4+1}$

vii.  $f(z) = \frac{1}{\operatorname{Sin}z}$

ii.  $f(z) = \frac{\operatorname{Sin}z}{(z-\pi)^2}$

viii.  $f(z) = \frac{\operatorname{Sin}2z}{(z+1)^3}$

iii.  $f(z) = \frac{z-2}{z^2} \operatorname{Sin}\left(\frac{1}{z-1}\right)$

ix.  $f(z) = \operatorname{Sin}z \operatorname{Sin}\left(\frac{1}{z}\right)$

iv.  $f(z) = \frac{1}{z^2 \operatorname{Sin}z}$

x.  $f(z) = z^{-3} \frac{e^{z^2}}{2}$

v.  $f(z) = \frac{z^2-4}{z^5-z^3}$

xi.  $f(z) = \frac{\operatorname{Sin}z}{z^2}$

vi.  $f(z) = \operatorname{Cot}z$

xii.  $f(z) = \frac{z^2+z^4}{\operatorname{Sin}\pi z}$

4. Find the residue of  $f(z) = z^{-3} \operatorname{Cosec}z \operatorname{Cosech}z$  at origin.

5. Find the sum of residue of  $f(z) = \frac{1}{z^4+1}$  at poles.

6. Prove that residue at  $z = ai$  of  $f(z) = \frac{e^{inz}}{z(z^2+a^2)^2}$  is  $\frac{e^{-na}(na+2)}{4a^4}$

7. Find the residue of the following functions at  $z = 0$

i.  $f(z) = \frac{1}{z+z^2}$

ii.  $f(z) = z \operatorname{Cos}\left(\frac{1}{z}\right)$

iii.  $f(z) = \frac{z-\operatorname{Sin}z}{z}$

iv.  $f(z) = \frac{\operatorname{Cot}z}{z^4}$

v.  $f(z) = \frac{\operatorname{Sin}hz}{z^4(1-z^2)}$

## CAUCHY'S RESIDUE THEOREM

If, except for a *finite* number of singular points, a function  $f$  is analytic inside a simple closed contour  $C$ , those singular points must be isolated. The following theorem, which is known as *Cauchy's residue theorem*, is a precise statement of the fact that if  $f$  is also analytic on  $C$  and if  $C$  is positively oriented, then the value of the integral of  $f$  around  $C$  is  $2\pi i$  times the *sum* of the residues of  $f$  at the singular points inside  $C$ .

**Theorem.** Let  $C$  be a simple closed contour, described in the positive sense. If a function  $f$  is analytic inside and on  $C$  except for a finite number of singular points  $z_k$  ( $k = 1, 2, \dots, n$ ) inside  $C$  (Fig), then

$$\int_C f(z) dz = 2\pi i \sum_{k=1}^n \text{Res}(f, z_k)$$

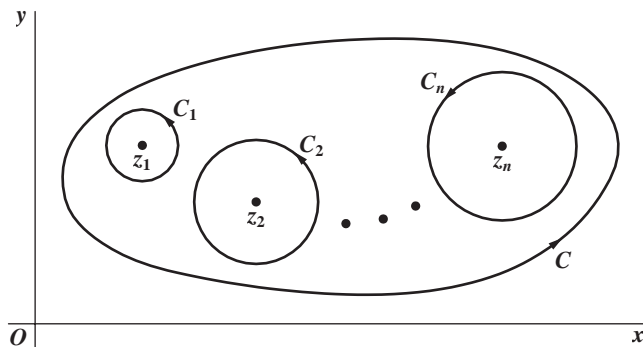

### Proof:

Let  $C_1, C_2, C_3, \dots, C_n$  are the circles with center  $z_1, z_2, z_3, \dots, z_n$  and radius of each is 'r' as 'r' is so small that these circles do not overlap and lies inside  $C$ .

$$\text{Now } \int_C f(z) dz = \int_{C_1} f(z) dz + \int_{C_2} f(z) dz + \dots + \int_{C_n} f(z) dz \dots (i)$$

Suppose  $f(z)$  has a pole (finite order singularity) of order 'm' at  $z = z_1$  then the Laurent's Series expansion will be

$$f(z) = \sum_{n=0}^{\infty} a_n (z - z_0)^n + \sum_{n=1}^m \frac{b_n}{(z - z_0)^n}$$

$$\text{Let } f(z) = [\varphi(z) = \sum_{n=0}^{\infty} a_n (z - z_0)^n] + \frac{b_1}{z - z_0} + \frac{b_2}{(z - z_0)^2} + \dots + \frac{b_m}{(z - z_0)^m}$$

$$\int_{C_1} f(z) dz = \int_{C_1} \varphi(z) dz + \int_{C_1} \frac{b_1}{z - z_0} dz + \int_{C_1} \frac{b_2}{(z - z_0)^2} dz + \dots + \int_{C_1} \frac{b_m}{(z - z_0)^m} dz$$

By using the following two results;

$$\int_{C_1} \varphi(z) dz = 0 \quad \text{and} \quad \int_{C_1} \frac{1}{(z - z_0)^m} dz = \begin{cases} 2\pi i & \text{if } m = 1 \\ 0 & \text{if } m \neq 1 \end{cases}$$

Then  $\int_{C_1} f(z)dz = 0 + b_1(2\pi i) + b_2(0) + \dots + b_m(0)$

$$\int_{C_1} f(z)dz = b_1(2\pi i)$$

$$\int_{C_1} f(z)dz = 2\pi i \text{Res}(f, z_1)$$

Similarly  $\int_{C_2} f(z)dz = 2\pi i \text{Res}(f, z_2)$

And continuing in this manner we get  $\int_{C_n} f(z)dz = 2\pi i \text{Res}(f, z_n)$

Using all values in (i)

$$\int_C f(z)dz = 2\pi i \text{Res}(f, z_1) + 2\pi i \text{Res}(f, z_2) + \dots + 2\pi i \text{Res}(f, z_n)$$

$$\int_C f(z)dz = 2\pi i [\text{Res}(f, z_1) + \text{Res}(f, z_2) + \dots + \text{Res}(f, z_n)]$$

$$\int_C f(z)dz = 2\pi i \sum_{k=1}^n \text{Res}(f, z_k) \quad \text{required result.}$$

**Example:** Evaluate the integral  $\int_C \frac{1}{(z-1)(z-2)^2} dz$  with  $C: |z| = 3$

**Solution:** Given  $f(z) = \frac{1}{(z-1)(z-2)^2}$  is a meromorphic function and has two poles at  $z = 1$  and  $z = -2$

$z = 1$  is simple pole And  $z = -2$  is a pole of order 4

For simple poles using  $\text{Res}(f, z_0) = \lim_{z \rightarrow z_0} [(z - z_0)f(z)]$

$$\text{Res}(f, 1) = \lim_{z \rightarrow 1} \left[ (z - 1) \frac{1}{(z-1)(z-2)^2} \right] = \frac{1}{9}$$

By using formula  $\text{Res}(f, z_0) = \frac{1}{(n-1)!} \lim_{z \rightarrow z_0} \frac{d^{n-1}}{dz^{n-1}} [(z - z_0)^n f(z)]$

$$\text{Res}(f, -2) = \frac{1}{(2-1)!} \lim_{z \rightarrow -2} \frac{d^{2-1}}{dz^{2-1}} [(z+2)^2 f(z)]$$

$$\text{Res}(f, -2) = \frac{1}{1!} \lim_{z \rightarrow -2} \frac{d}{dz} \left[ (z+2)^2 \frac{1}{(z-1)(z-2)^2} \right] = \lim_{z \rightarrow -2} \frac{d}{dz} \left[ \frac{1}{(z-1)} \right]$$

$$\text{Res}(f, -2) = \lim_{z \rightarrow -2} \left[ \frac{-1}{(z-1)^2} \right] = -\frac{1}{9} \quad \text{after solving}$$

Now  $\int_C \frac{1}{(z-1)(z-2)^2} dz = 2\pi i \sum_{k=1}^2 \text{Res}(f, z_k)$

$$\int_C \frac{1}{(z-1)(z-2)^2} dz = 2\pi i [\text{Res}(f, 1) + \text{Res}(f, -2)] = 0$$

$$\int_C \frac{1}{(z-1)(z-2)^2} dz = 0$$

**Example:** Evaluate the integral  $\int_C \frac{z^2-z+1}{(z-1)(z-4)(z+3)} dz$  with  $C: |z| = 5$

**Solution:** Given  $f(z) = \frac{z^2-z+1}{(z-1)(z-4)(z+3)}$  has three poles at  $z = 1$ ,  $z = 4$  and

$z = -3$  of order 1 (Simple poles)

For simple poles using  $Res(f, z_0) = \lim_{z \rightarrow z_0} [(z - z_0)f(z)]$

$$Res(f, 1) = \lim_{z \rightarrow 1} \left[ (z - 1) \frac{z^2 - z + 1}{(z-1)(z-4)(z+3)} \right] = \lim_{z \rightarrow 1} \left[ \frac{z^2 - z + 1}{(z-4)(z+3)} \right] = -\frac{1}{12}$$

$$Res(f, 4) = \lim_{z \rightarrow 4} \left[ (z - 4) \frac{z^2 - z + 1}{(z-1)(z-4)(z+3)} \right] = \lim_{z \rightarrow 4} \left[ \frac{z^2 - z + 1}{(z-1)(z+3)} \right] = \frac{13}{21}$$

$$Res(f, -3) = \lim_{z \rightarrow -3} \left[ (z + 3) \frac{z^2 - z + 1}{(z-1)(z-4)(z+3)} \right] = \lim_{z \rightarrow -3} \left[ \frac{z^2 - z + 1}{(z-1)(z-4)} \right] = \frac{13}{28}$$

$$\text{Now } \int_C \frac{z^2 - z + 1}{(z-1)(z-4)(z+3)} dz = 2\pi i \sum_{k=1}^3 Res(f, z_k)$$

$$\int_C \frac{z^2 - z + 1}{(z-1)(z-4)(z+3)} dz = 2\pi i [Res(f, 1) + Res(f, 4) + Res(f, -3)] = 1$$

$$\int_C \frac{z^2 - z + 1}{(z-1)(z-4)(z+3)} dz = 1$$



### RESIDUE AT INFINITY

Suppose that a function  $f$  is analytic throughout the finite plane except for a finite number of singular points interior to a positively oriented simple closed contour  $C$ . Next, let  $R_1$  denote a positive number which is large enough that  $C$  lies inside the circle  $|z| = R_1$  (see Fig.). The function  $f$  is evidently analytic throughout the domain  $R_1 < |z| < \infty$  and is said to be an isolated singular point of  $f$ .

Now let  $C_0$  denote a circle  $|z| = R_0$ , oriented in the *clockwise* direction, where  $R_0 > R_1$ . The **residue of  $f$  at infinity** is defined by means of the equation

$$\int_{C_0} f(z) dz = 2\pi i \operatorname{Res}_{z=\infty} f(z) = -2\pi i \operatorname{Res}_{z=0} \left[ \frac{1}{z^2} f\left(\frac{1}{z}\right) \right]$$

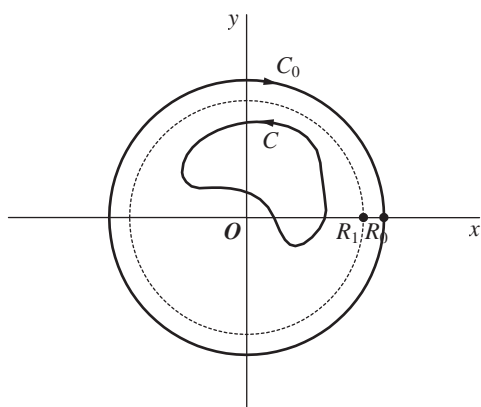

We may use theorem as follows to use the Cauchy's Residue theorem since it involves only one residue.

#### **Theorem.**

If a function  $f$  is analytic everywhere in the finite plane except for a finite number of singular points interior to a positively oriented simple closed contour  $C$ , then

$$\int_C f(z) dz = 2\pi i \operatorname{Res}_{z=0} \left[ \frac{1}{z^2} f\left(\frac{1}{z}\right) \right]$$

#### **Remark:**

If want to check the behavior of function at infinity then

- i. Make substitution  $z = \frac{1}{w}$
- ii. Investigate the behavior of new function at  $w = 0$  actually that is  $z = \infty$

**Exercise 48: (visit @ Youtube “learning with Usman Hamid”)**

1. Evaluate the integral  $\int_C \frac{ze^z}{(z^2+a^2)^2} dz$  where C is closed contour encloses the point  $z = -ai$
2. Evaluate the integral  $\int_C \frac{(1-z^4)e^{2z}}{z^5} dz$  where C is a unit circle.
3. Evaluate the integral  $\int_C \frac{e^{2z}}{\cosh \pi z} dz$  where C is a unit circle i.e.  $|z| = 1$
4. Evaluate the integral  $\int_C \frac{1}{z^3(z-1)^4} dz$  with  $C: |z-2| = \frac{3}{2}$
5. Evaluate the integral  $\int_C \frac{2z+3}{z(z^2+1)(z+1)^2} dz$  with  $C: |z| = 3$
6. Evaluate the integral  $\int_C \frac{1}{z+2} dz$  with  $C: |z| = 1$  and deduce that  $\int_0^\pi \frac{1+2\cos\theta}{5+4\cos\theta} d\theta = 0$
7. Evaluate the integral  $\int_C \frac{12z-7}{(2z+3)(z-1)^2} dz$  with  $C: |z| = 2$
8. Evaluate the integral  $\int_C \frac{12z-7}{(2z+3)(z-1)^2} dz$  with  $C: |z+i| = \sqrt{3}$
9. Evaluate the integral  $\int_C \frac{e^z}{(z-1)^n} dz$  with  $C: |z| = 2$
10. Evaluate the integral  $\int_C \frac{1}{(z^4+1)} dz$  with C is a circle  $x^2 + y^2 = 2x$
11. Evaluate the integral  $\int_C \frac{1}{(z-1)(z-2)} dz$  with  $C: |z-2| = \frac{1}{2}$
12. Evaluate the integral  $\int_C \frac{1}{z^2(z-1)^n} dz$  where  $n \in \mathbb{N}$  and C is a simple closed curve surrounding the origin and
  - (i) ‘a’ is inside C
  - (ii) ‘a’ is outside C
13. Evaluate the integral  $\oint_C \frac{1}{(z-1)^2(z-3)} dz$  where
  - i. C is the rectangle defined by  $x = 0, x = 4$  and  $y = -1, y = 1$
  - ii. C is the circle  $|z| = 2$

**Exercise 49: (visit @ Youtube “learning with Usman Hamid”)**

1. Evaluate the integral  $\int_C \frac{e^z-1}{z^4} dz$  where C is a unit circle i.e.  $|z| = 1$
2. Evaluate the integral  $\int_C \text{Cosh}\left(\frac{1}{z^2}\right) dz$  with  $C: |z| = 1$
3. Evaluate the integral  $\int_C \frac{1}{z(z-2)^5} dz$  with  $C: |z-2| = 1$
4. Evaluate the integral  $\int_C \frac{4z-5}{z(z-1)} dz$  with  $C: |z| = 2$
5. Evaluate the integral  $\int_C f(z) dz$  with  $C: |z| = 3$  in the positive sense.
  - i.  $f(z) = \frac{e^{-z}}{z^2}$
  - ii.  $f(z) = \frac{e^{-z}}{(z-1)^2}$
  - iii.  $f(z) = z^2 e^{\frac{1}{z}}$
  - iv.  $\frac{z+1}{z^2-2z}$
6. Evaluate the integral  $\int_C f(z) dz$  with  $C: |z| = 2$  in the positive sense.
  - i.  $f(z) = \frac{z^5}{(1-z)^3}$
  - ii.  $f(z) = \frac{1}{1+z^2}$
  - iii.  $f(z) = \frac{1}{z}$
7. Evaluate the integral  $\int_C \frac{z^3(1-3z)}{(1+z)(1+2z^2)} dz$  with  $C: |z| = 3$
8. Evaluate the integral  $\oint_C \frac{2z+6}{z^2+4} dz$  where C is the circle  $|z-i| = 2$

**ZERO OF A FUNCTION:**

A number  $z = z_0$  is called zero of a function  $f(z)$  if  $f(z_0) = 0$ . further we can say that an analytic function  $f(z)$  has a zero of order ‘n’ at point  $z = z_0$  if  $f(z_0) = 0, f'(z_0) = 0, f''(z_0) = 0, \dots, f^{n-1}(z_0) = 0$  but  $f^n(z_0) \neq 0$

**Remark:**

- i. A function  $f(z)$  is analytic in some disk  $|z - z_0| < R$  has a zero of order ‘n’ at  $z = z_0$  iff  $f(z)$  can be written as  $f(z) = (z - z_0)^n \varphi(z)$  where  $\varphi(z)$  is analytic at  $z_0$  and  $\varphi(z_0) \neq 0$
- ii. A zero of order one is called simple zero.
- iii. A zero of order ‘n’ is called a zero of multiplicity ‘n’

**Example:**

- i. For  $f(z) = z - 3i; z_0 = 3i$  we have  $f(z_0) = 0$  but  $f'(z_0) \neq 0$  then  $z_0 = 3i$  is a simple zero of given function.
- ii. For  $f(z) = (z - i)^3; z_0 = i$   
we have  $f(z_0) = 0, f'(z_0) = 0, f''(z_0) = 0$  but  $f'''(z_0) \neq 0$  then  $z_0 = i$  is a zero of order 3 or zero of multiplicity 3.

**SINGULARITY:**

If a complex valued function  $f(z)$  failed to be analytic at point  $z = z_0$  then this point is said to be singular point or singularity.

**Example:**

- i. Function  $f(z) = \frac{e^z}{z-1}$  is non – analytic at  $z_0 = 1$  so  $z_0 = 1$  is a singularity of  $f(z)$
- ii. Function  $f(z) = \frac{\text{Sin}z}{z}$  is non – analytic at  $z_0 = 0$  so  $z_0 = 0$  is a singularity of  $f(z)$
- iii. Function  $f(z) = e^{\frac{1}{z-2}}$  is non – analytic at  $z_0 = 2$  so  $z_0 = 2$  is a singularity of  $f(z)$

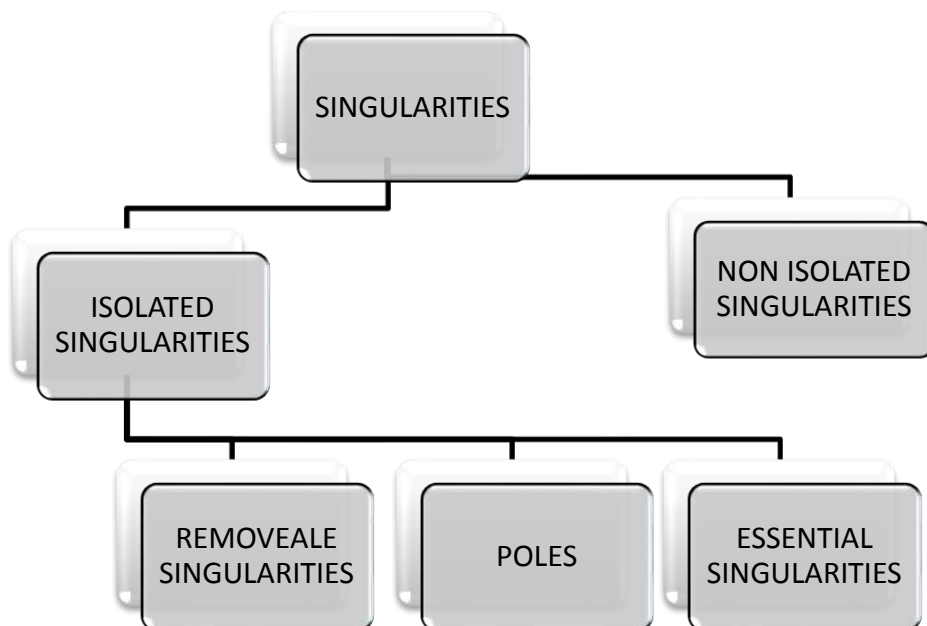
**TYPES OF SINGULARITES**

**ISOLATED SINGULARITIES:**

A point  $z = z_0$  is said to be an isolated singularity of a function  $f(z)$  if  $f(z)$  is analytic at each point in the neighborhood of  $z = z_0$  except at  $z = z_0$

**Example:**

- i. Function  $f(z) = \frac{e^z}{z-1}$  is non – analytic at  $z_0 = 1$  so  $z_0 = 1$  is an isolated singularity of  $f(z)$
- ii. Function  $f(z) = \frac{1}{\text{Sin}\pi z}$  is non – analytic at  $z_0 = \frac{1}{k}$  ;  $k = \pm 1, \pm 2, \dots$  so  $z_0 = \frac{1}{k}$  is an isolated singularity of  $f(z)$

**NON – ISOLATED SINGULARITIES:**

A point  $z = z_0$  is said to be a non – isolated singularity of a function  $f(z)$  if in the neighborhood of  $z = z_0$  there exists other points where  $f(z)$  is not analytic.

**Example:**

- i. Function  $f(z) = \log z$  is non – analytic at  $z_0 = 0$  so  $z_0 = 0$  is a non – isolated singularity of  $f(z)$  there exist also other points where the function will be non – analytic.
- ii. Function  $f(z) = \frac{1}{\text{Sin}\pi z}$  is non – analytic at  $z_0 = 0$  so  $z_0 = 0$  is a non – isolated singularity of  $f(z)$  there exist also other points where the function will be non – analytic.

**REMOVEABLE (ARTIFICIAL) SINGULARITIES:**

A point  $z = z_0$  is said to be a removable singularity of a function  $f(z)$  if the principle part of Laurent's Series expansion contains no term.

i.e. for Laurent's Series  $f(z) = \sum_{n=0}^{\infty} a_n(z - z_0)^n + \sum_{n=1}^{\infty} \frac{b_n}{(z - z_0)^n}$

we have the form as follows;

$$f(z) = \sum_{n=0}^{\infty} a_n(z - z_0)^n$$

**Example:**

- i. Function  $f(z) = \frac{\text{Sin}z}{z}$  has removable singularity at  $z_0 = 0$   
 Since  $f(z) = \frac{\text{Sin}z}{z} = \frac{1}{z} \left[ z - \frac{z^3}{3!} + \frac{z^5}{5!} - \frac{z^7}{7!} + \dots \right] = 1 - \frac{z^2}{3!} + \frac{z^4}{5!} - \frac{z^6}{7!} + \dots$   
 contains no Principle Part.
- ii. Function  $f(z) = \frac{1 - \text{Cos}z}{z^2}$  has removeable singularity at  $z_0 = 0$   
 Since  $f(z) = \frac{1 - \text{Cos}z}{z^2} = \frac{1}{2!} - \frac{z^2}{4!} + \frac{z^4}{6!} - \dots$  contains no Principle Part.

**Riemann's Theorem:**

Suppose that a function  $f(z)$  is bounded analytic in some deleted neighborhood  $0 < |z - z_0| < \epsilon$  of  $z_0$ . If  $f(z)$  is not analytic at  $z_0$  then it has a removable singularity there.

**Proof:**

Suppose that  $f(z)$  is not analytic at  $z_0$  then the point  $z_0$  must be an isolated singularity of  $f(z)$ . And  $f(z)$  is represented as follows;

$$f(z) = \sum_{n=0}^{\infty} a_n(z - z_0)^n + \sum_{n=1}^{\infty} \frac{b_n}{(z - z_0)^n}$$

Throughout the deleted neighbourhood  $0 < |z - z_0| < \epsilon$ . If  $C$  denotes a positively oriented circle  $|z - z_0| = \rho$  where  $\rho < \epsilon$  then we may

$$\text{write } b_n = \frac{1}{2\pi i} \int_C \frac{f(z)}{(z - z_0)^{-n+1}} dz \quad (n=1,2,3,\dots)$$

$$\Rightarrow |b_n| = \left| \frac{1}{2\pi i} \int_C \frac{f(z)}{(z - z_0)^{-n+1}} dz \right|$$

$$\Rightarrow |b_n| \leq \left| \frac{1}{2\pi i} \right| \int_C |f(z)| \left| \frac{dz}{(z - z_0)^{-n+1}} \right|$$

$$\Rightarrow |b_n| \leq \frac{1}{2\pi|i|} \int_C |f(z)| \frac{|dz|}{|z - z_0|^{-n+1}} \leq \frac{1}{2\pi|i|} \frac{M}{\rho^{-n+1}} \int_C |dz| \quad \because |f(z)| \leq M$$

$$\Rightarrow |b_n| \leq \frac{1}{2\pi|i|} \frac{M}{\rho^{-n+1}} (2\pi\rho) = M\rho^n \Rightarrow |b_n| \leq M\rho^n \quad (n=1,2,3,\dots)$$

Since the coefficients  $b_n$  are constants and since  $\rho$  can be chosen arbitrarily small, we may conclude that  $b_n = 0$ ; ( $n = 1,2,3, \dots$ ) in Laurent's Series (given above).

This tells us that  $z_0$  is a removable singularity of  $f(z)$  and proved the theorem.

**POLE**

A point  $z = z_0$  is called pole of order 'n' of a function  $f(z)$  if the principle part of Laurent's Series expansion contains finite numbers of terms.

i.e. For Laurent's Series  $f(z) = \sum_{n=0}^{\infty} a_n(z - z_0)^n + \sum_{n=1}^{\infty} \frac{b_n}{(z - z_0)^n}$

we have the form as follows;

$$f(z) = \sum_{n=0}^{\infty} a_n(z - z_0)^n + \sum_{n=1}^k \frac{b_n}{(z - z_0)^n}$$

**Example:**

i. Function  $f(z) = \frac{\sin z}{z^4}$  has a pole of order '3' at  $z_0 = 0$

Since  $f(z) = \frac{\sin z}{z^4} = \frac{1}{z^4} \left[ z - \frac{z^3}{3!} + \frac{z^5}{5!} - \frac{z^7}{7!} + \dots \right] = \frac{1}{z^3} - \frac{1}{3!z} + \frac{z}{5!} - \frac{z^3}{7!} + \dots$   
contains finite terms.

ii. Function  $f(z) = \frac{1}{z-3}$  has a pole of order '1' at  $z_0 = 3$

**ESSENTIAL SINGULARITIES:**

A point  $z = z_0$  is called pole of order 'n' of a function  $f(z)$  if the principle part of Laurent's Series expansion contains infinite numbers of terms.

i.e. for Laurent's Series  $f(z) = \sum_{n=0}^{\infty} a_n(z - z_0)^n + \sum_{n=1}^{\infty} \frac{b_n}{(z - z_0)^n}$

we have the form as follows;

$$f(z) = \sum_{n=0}^{\infty} a_n(z - z_0)^n + \sum_{n=1}^{\infty} \frac{b_n}{(z - z_0)^n}$$

**Example:**

i. Function  $f(z) = \sin\left(\frac{1}{z}\right) = \frac{1}{z} - \frac{1}{3!z^3} + \frac{1}{5!z^5} - \dots$  has an essential singularity at  $z_0 = 0$

ii. Function  $f(z) = e^{1/z} = 1 + \frac{1}{z} + \frac{1}{2!z^2} + \frac{1}{3!z^3} + \dots$  has an essential singularity at  $z_0 = 0$

**Remark:**

i. A function  $f(z)$  is analytic in a domain  $0 < |z - z_0| < R$  has a pole of order 'n' at  $z = z_0$  iff  $f(z)$  can be written as  $f(z) = \frac{\varphi(z)}{(z - z_0)^n}$  where

$\varphi(z)$  is analytic at  $z_0$  and  $\varphi(z_0) \neq 0$

ii. If the functions  $g$  &  $h$  are analytic at  $z = z_0$  have a zero of order 'n' at  $z = z_0$  and  $g(z_0) \neq 0$  then the function  $f(z) = \frac{g(z)}{h(z)}$  has a pole of order 'n' at  $z = z_0$

**Remark:**

If want to check the behavior of function at infinity then

- i. Make substitution  $z = \frac{1}{w}$
- ii. Investigate the behavior of new function at  $w = 0$  actually that is  $z = \infty$

**Example:**

Find the nature of singularity of the function  $f(z) = e^{2z}$  at  $z = \infty$

**Solution:**

Given that  $f(z) = e^{2z}$

Make substitution  $z = \frac{1}{w} \Rightarrow f\left(\frac{1}{w}\right) = e^{2/w}$  then  $w = 0$  is singularity.

$$\text{Let } g(w) = e^{2/w} = 1 + \frac{2}{w} + \frac{\left(\frac{2}{w}\right)^2}{2!} + \frac{\left(\frac{2}{w}\right)^3}{3!} + \dots$$

$$\Rightarrow g(w) = e^{2/w} = 1 + \frac{2}{w} + \frac{2}{2w^2} + \frac{2}{6w^3} + \dots$$

$\Rightarrow g(w)$  has an essential singularity at  $w = 0$

$\Rightarrow f(z)$  has an essential singularity at  $z = \infty$

**Example:**

Find the nature of singularity of the function  $f(z) = z^2(z + 1)$  at  $z = \infty$

**Solution:**

Given that  $f(z) = z^2(z + 1)$

Make substitution  $z = \frac{1}{w} \Rightarrow f\left(\frac{1}{w}\right) = \frac{1}{w^2}\left(\frac{1}{w} + 1\right)$  then  $w = 0$  is singularity.

$$\text{Let } g(w) = \frac{1}{w^2}\left(\frac{1}{w} + 1\right) = \frac{1}{w^2}\left(\frac{1+w}{w}\right) = \frac{1+w}{w^3}$$

$$\Rightarrow g(w) = \frac{1+w}{(w-0)^3} = \frac{\varphi(w)}{(w-0)^3} \text{ (say)}$$

$\Rightarrow g(w)$  has a pole of order 3 at  $w = 0$

$\Rightarrow f(z)$  has a pole of order 3 at  $z = \infty$



**Exercise 50: (visit @ Youtube “learning with Usman Hamid”)**

1. Discuss the nature of singularity of the given functions

$$\text{i. } f(z) = \frac{e^z}{(z-1)^3}$$

$$\text{v. } f(z) = \frac{z}{z^4+1}$$

$$\text{ii. } f(z) = \frac{z - \text{Sin}z}{z^3}$$

$$\text{vi. } f(z) = \frac{1 - \text{Cosh}z}{z^2}$$

$$\text{iii. } f(z) = e^{\frac{1}{2z}}$$

$$\text{vii. } f(z) = e^{1/z}$$

$$\text{iv. } f(z) = \text{Tanz}$$

$$\text{viii. } f(z) = \frac{1}{z^2(1-z)}$$

$$\text{ix. } f(z) = \frac{z^2+z-2}{z+1}$$

$$\text{x. } f(z) = \text{Sin}\left(\frac{1}{1-z}\right); z = 1$$

2. Find the zeros and discuss the nature of singularity of

$$f(z) = \frac{z-2}{z^2} \text{Sin}\left(\frac{1}{1-z}\right)$$

3. Let  $f(z) = e^{\frac{1}{z}}$  show that there are infinite number of zero's in every neighbourhood of  $z = 0$  which satisfy  $e^{\frac{1}{z}} = -1$

4. Determine Poles and order of each Pole of given functions;

$$\text{i. } f(z) = \text{Cot}z$$

$$\text{ii. } f(z) = \frac{z^2-4}{z^5-z^3}$$

$$\text{iii. } f(z) = \frac{1}{z^2 \text{Sin}z}$$

5. Find the zero's and poles with their orders and essential singularity of

$$f(z) = \frac{1}{(z^2-1)^2} \text{Sin}\left(\frac{1}{z}\right)$$

6. In each case, write the principle part of the function at its isolated singular point and determine whether that point is a removable singular point, an essential singular point or a pole.

$$\text{i. } f(z) = \frac{e^z}{(z-1)^3}$$

$$\text{ii. } f(z) = \frac{z - \text{Sin}z}{z^3}$$

$$\text{iii. } f(z) = e^{\frac{1}{2z}}$$

$$\text{iv. } f(z) = \text{Sin}\left(\frac{1}{1-z}\right); z = 1$$

$$\text{v. } f(z) = \text{Tanz}$$

### INTERESTING FACT

A function  $f$  is said to be meromorphic in a domain  $D$  if it is analytic throughout  $D$  except for poles. Suppose now that  $f$  is meromorphic in the domain interior to a positively oriented simple closed contour  $C$  and that it is analytic and nonzero on  $C$ . The image  $\Gamma$  of  $C$  under the transformation  $w = f(z)$  is a closed contour, not necessarily simple, in the  $w$  plane (Fig.). As a point  $z$  traverses  $C$  in the positive direction, its images  $w$  traverses  $\Gamma$  in a particular direction that determines the orientation of  $\Gamma$ . Note that since  $f$  has no zeros on  $C$ , the contour  $\Gamma$  does not pass through the origin in the  $w$  plane.

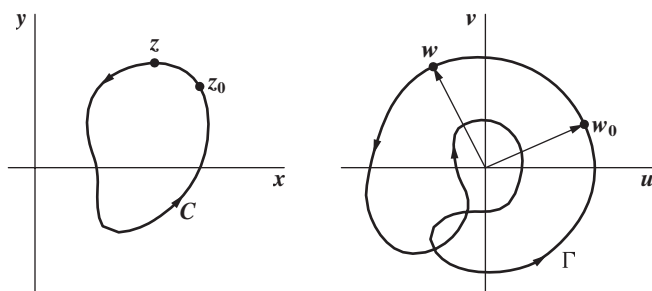

Let  $w_0$  and  $w$  be points on  $\Gamma$ , where  $w_0$  is fixed and  $\varphi_0$  is a value of  $\arg w_0$ . Then let  $\arg w$  vary continuously, starting with the value  $\varphi_0$ , as the point  $w$  begins at the point  $w_0$  and traverses  $\Gamma$  once in the direction of orientation assigned to it by the mapping  $w = f(z)$ . When  $w$  returns to the point  $w_0$ , where it started,  $\arg w$  assumes a particular value of  $\arg w_0$ , which we denote by  $\varphi_1$ . Thus the change in  $\arg w$  as  $w$  describes  $T$  once in its direction of orientation is  $\varphi_1 - \varphi_0$ . This change is, of course, independent of the point  $w_0$  chosen to determine it. Since  $w = f(z)$ , the number  $\varphi_1 - \varphi_0$  is, in fact, the change in argument of  $f(z)$  as  $z$  describes  $C$  once in the positive direction, starting with a point  $z_0$ ; and we write

$$\Delta_C \arg f(z) = \varphi_1 - \varphi_0.$$

The value of  $\Delta_C \arg f(z)$  is evidently an integral multiple of  $2\pi$ , and the integer  $\frac{1}{2\pi} \Delta_C \arg f(z)$  represents the number of times the point  $w$  winds around the origin in the  $w$  plane. For that reason, this integer is sometimes called the **winding number** of  $\Gamma$  with respect to the origin  $w = 0$ . It is positive if  $\Gamma$  winds around the origin in the counterclockwise direction and negative if it winds clockwise around that point. The winding number is always zero when  $\Gamma$  does not enclose the origin.

The winding number can be determined from the number of zeros and poles of  $f$  interior to  $C$ . The number of poles is necessarily finite. Likewise, with the understanding that  $f(z)$  is not identically equal to zero everywhere else inside  $C$ , it is easily shown that the zeros of  $f$  are finite in number and are all of finite order.

Suppose now that  $f$  has  $N$  zeros and  $P$  poles in the domain interior to  $C$ . We agree that  $f$  has  $m_0$  zeros at a point  $z_0$  if it has a zero of order  $m_0$  there; and if  $f$  has a pole of order  $m_p$  at  $z_0$ , that pole is to be counted  $m_p$  times.

The following theorem, which is known as the **argument principle**, states that the winding number is simply the difference  $N - P$ .

### ARGUMENT PRINCIPLE THEOREM.

Let  $C$  denote a positively oriented simple closed contour, if  $f(z)$  is meromorphic function inside  $C$  and has no zero's on  $C$  then

$$\frac{1}{2\pi i} \int_C \frac{f'(z)}{f(z)} dz = N - P$$

Where  $N$  is number of zero's and  $P$  is number of poles inside  $C$ .

**Proof:**

Construct the following figure;

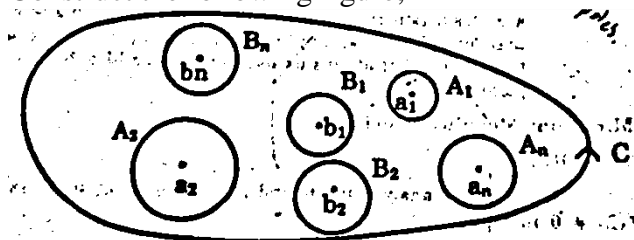

Consider  $z = a_i; i = 1, 2, 3, \dots, m$  are the zeros of  $f(z)$  then  $N = \sum_{i=1}^m r_i$  ( $r_i$  be the order of  $a_i$ ) and  $z = b_i; i = 1, 2, 3, \dots, n$  are the poles of  $f(z)$  then  $P = \sum_{i=1}^n s_i$  ( $s_i$  be the order of  $b_i$ ) where each zero and pole enclosed by circle  $A_1, A_2, \dots, A_m$  and  $B_1, B_2, \dots, B_n$  respectively. Where  $\rho$  is the radius of each circle with centre, zero's and poles.

We have to prove 
$$\frac{1}{2\pi i} \int_C \frac{f'(z)}{f(z)} dz = \sum_{i=1}^m r_i - \sum_{i=1}^n s_i$$

In this case we have a multiply connected region where  $C$  contain many circles inside. So by using consequence of Cauchy Fundamental Theorem;

$$\frac{1}{2\pi i} \int_C \frac{f'(z)}{f(z)} dz = \sum_{i=1}^m \frac{1}{2\pi i} \int_{A_i} \frac{f'(z)}{f(z)} dz + \sum_{i=1}^n \frac{1}{2\pi i} \int_{B_i} \frac{f'(z)}{f(z)} dz \dots\dots(i)$$

Since  $z = a_i$  is the zero of order  $r_i$  of  $f(z)$

then we can write a function  $f(z) = (z - a_i)^{r_i} \varphi(z)$

$\Rightarrow \log f(z) = \log(z - a_i)^{r_i} + \log \varphi(z)$

$\Rightarrow \log f(z) = r_i \log(z - a_i) + \log \varphi(z)$

$$\begin{aligned} \Rightarrow \frac{f'(z)}{f(z)} &= \frac{r_i}{z-a_i} + \frac{\varphi'(z)}{\varphi(z)} \\ \Rightarrow \int_{A_i} \frac{f'(z)}{f(z)} dz &= \int_{A_i} \frac{r_i}{z-a_i} dz + \int_{A_i} \frac{\varphi'(z)}{\varphi(z)} dz \\ \Rightarrow \int_{A_i} \frac{f'(z)}{f(z)} dz &= \int_{A_i} \frac{r_i}{z-a_i} dz \qquad \qquad \qquad \therefore \int_{A_i} \frac{\varphi'(z)}{\varphi(z)} dz = 0 \end{aligned}$$

Now consider  $z - a_i = \rho e^{i\theta}$ ,  $dz = i\rho e^{i\theta} d\theta$  ;  $0 \leq \theta \leq 2\pi$

$$\begin{aligned} \Rightarrow \int_{A_i} \frac{f'(z)}{f(z)} dz &= \int_{A_i} \frac{r_i}{\rho e^{i\theta}} \cdot i\rho e^{i\theta} d\theta \Rightarrow \int_{A_i} \frac{f'(z)}{f(z)} dz = ir_i \int_{A_i} d\theta = 2\pi ir_i \\ \Rightarrow \frac{1}{2\pi i} \int_{A_i} \frac{f'(z)}{f(z)} dz &= ir_i \int_{A_i} d\theta = r_i \\ \Rightarrow \sum_{i=1}^m \frac{1}{2\pi i} \int_{A_i} \frac{f'(z)}{f(z)} dz &= \sum_{i=1}^m r_i \qquad \dots\dots\dots(A) \end{aligned}$$

Also Since  $z = b_i$  are the poles of order  $s_i$  of  $f(z)$

then we can write a function  $f(z) = \frac{\varphi(z)}{(z-b_i)^{s_i}}$

$$\begin{aligned} \Rightarrow \log f(z) &= \log \varphi(z) - \log(z-b_i)^{s_i} \\ \Rightarrow \log f(z) &= \log \varphi(z) - s_i \log(z-b_i) \\ \Rightarrow \frac{f'(z)}{f(z)} &= \frac{\varphi'(z)}{\varphi(z)} - \frac{s_i}{z-b_i} \\ \Rightarrow \int_{B_i} \frac{f'(z)}{f(z)} dz &= \int_{B_i} \frac{\varphi'(z)}{\varphi(z)} dz - \int_{B_i} \frac{s_i}{z-b_i} dz \\ \Rightarrow \int_{B_i} \frac{f'(z)}{f(z)} dz &= - \int_{B_i} \frac{s_i}{z-b_i} dz \qquad \qquad \qquad \therefore \int_{A_i} \frac{\varphi'(z)}{\varphi(z)} dz = 0 \end{aligned}$$

Now consider  $z - b_i = \rho e^{i\theta}$ ,  $dz = i\rho e^{i\theta} d\theta$  ;  $0 \leq \theta \leq 2\pi$

$$\begin{aligned} \Rightarrow \int_{B_i} \frac{f'(z)}{f(z)} dz &= - \int_{B_i} \frac{s_i}{\rho e^{i\theta}} \cdot i\rho e^{i\theta} d\theta \Rightarrow \int_{B_i} \frac{f'(z)}{f(z)} dz = -is_i \int_{B_i} d\theta = -2\pi is_i \\ \Rightarrow \frac{1}{2\pi i} \int_{B_i} \frac{f'(z)}{f(z)} dz &= -is_i \int_{B_i} d\theta = -s_i \\ \Rightarrow \sum_{i=1}^n \frac{1}{2\pi i} \int_{B_i} \frac{f'(z)}{f(z)} dz &= - \sum_{i=1}^n s_i \qquad \dots\dots\dots(B) \end{aligned}$$

Using (A) and (B) in (i) we get

$$\frac{1}{2\pi i} \int_C \frac{f'(z)}{f(z)} dz = \sum_{i=1}^m r_i - \sum_{i=1}^n s_i$$

$$\text{Or} \quad \frac{1}{2\pi i} \int_C \frac{f'(z)}{f(z)} dz = N - P$$

## ROUCHÉ'S THEOREM

*Rouché's theorem* is a consequence of the argument principle. It can be useful in locating regions of the complex plane in which a given analytic function has zeros.

### **Theorem:**

Let  $C$  denote a simple closed contour, and suppose that two functions  $f(z)$  and  $g(z)$  are analytic inside and on  $C$  also  $|g(z)| < |f(z)|$  on  $C$ . then  $f(z) + g(z)$  and  $f(z)$  have the same number of zeros inside  $C$ .

The orientation of  $C$  in the statement of the theorem is evidently immaterial. Thus, in the proof here, we may assume that the orientation is positive.

### **Proof:**

Let  $F(z) = \frac{g(z)}{f(z)} \Rightarrow g(z) = f(z) \cdot F(z) \Rightarrow g = fF$

If  $N_1$  and  $N_2$  are the number of zeros inside  $C$  of  $f + g$  and  $f$  respectively, then by using Argument Principle Theorem (using the fact that function has no poles inside  $C$ )

$$N_1 - N_2 = \frac{1}{2\pi i} \int_C \frac{f'+g'}{f+g} dz - \frac{1}{2\pi i} \int_C \frac{f'}{f} dz$$

$$N_1 - N_2 = \frac{1}{2\pi i} \int_C \left[ \frac{f'+g'}{f+g} - \frac{f'}{f} \right] dz$$

$$N_1 - N_2 = \frac{1}{2\pi i} \int_C \left[ \frac{f'+f'F+F'f}{f+fF} - \frac{f'}{f} \right] dz \quad \because g = fF \Rightarrow g' = f'F + F'f$$

$$N_1 - N_2 = \frac{1}{2\pi i} \int_C \left[ \frac{f'(1+F)+F'f}{f(1+F)} - \frac{f'}{f} \right] dz$$

$$N_1 - N_2 = \frac{1}{2\pi i} \int_C \left[ \frac{f'}{f} + \frac{F'}{(1+F)} - \frac{f'}{f} \right] dz = \frac{1}{2\pi i} \int_C \left[ \frac{F'}{(1+F)} \right] dz$$

$$N_1 - N_2 = \frac{1}{2\pi i} \int_C F' [1 + F]^{-1} dz$$

$$N_1 - N_2 = \frac{1}{2\pi i} \int_C F' [1 - F + F^2 - F^3 + \dots] dz$$

$$N_1 - N_2 = \frac{1}{2\pi i} \int_C F' \left[ \sum_{i=1}^{\infty} (-1)^i F^i \right] dz$$

$$N_1 - N_2 = 0$$

$$N_1 = N_2 \quad \text{hence proved}$$

Where we used the fact  $|g(z)| < |f(z)| \Rightarrow \frac{|g(z)|}{|f(z)|} < 1 \Rightarrow |F| < 1$  on  $C$

then  $\sum_{i=1}^{\infty} (-1)^i F^i$  is a uniform convergent series being Geometric.

Then  $\sum_{i=1}^{\infty} (-1)^i F^i = 0$

## CHAPTER

## 7

---

**APPLICATIONS OF RESIDUES  
CONTOUR INTEGRATION**

We turn now to some important applications of the theory of residues, which was developed in Chap. 6. The applications include evaluation of certain types of definite and improper integrals occurring in *real* analysis and applied mathematics.

**TYPE – I:**

If we have an integral of the form  $\int_0^{2\pi} F(\sin\theta, \cos\theta) d\theta$  where  $F$  is a rational function of  $\sin\theta$  and  $\cos\theta$  then we can solve it using following procedure.

- Put  $z = e^{i\theta}$  ;  $0 \leq \theta \leq 2\pi \Rightarrow \frac{dz}{d\theta} = ie^{i\theta} = iz \Rightarrow d\theta = \frac{dz}{iz}$
- Put  $\sin\theta = \frac{z-z^{-1}}{2i}$  and  $\cos\theta = \frac{z+z^{-1}}{2}$
- Rewrite the integral in the form  $\int_0^{2\pi} F(\theta) d\theta = \int_C F(z) dz$  where  $C$  is positively oriented unit circle  $|z| = 1$
- Calculate the poles of  $F(z)$ . Say at  $z_0, z_1, z_2, \dots$  select those poles which lie in the unit circle  $|z| = 1$ . Then find the residues at the selected poles  $R_1(F, z_0), R_2(F, z_1)$  etc.
- Using Cauchy Residue Formula make the form as follows;

$$\int_0^{2\pi} F(\sin\theta, \cos\theta) d\theta = \int_C F(z) dz = 2\pi i \sum_{j=1}^n R_j$$

**Example:** Prove that  $\int_0^{2\pi} \frac{d\theta}{a+b\cos\theta} = \frac{2\pi}{\sqrt{a^2-b^2}}$  where  $a > b > 0$

**Solution:**

- Put  $z = e^{i\theta}$  ;  $0 \leq \theta \leq 2\pi \Rightarrow \frac{dz}{d\theta} = ie^{i\theta} = iz \Rightarrow d\theta = \frac{dz}{iz}$
- $\cos\theta = \frac{z+z^{-1}}{2}$
- Rewrite the integral in the form  $\int_0^{2\pi} \frac{d\theta}{a+b\cos\theta} = \int_C \frac{\frac{dz}{iz}}{a+b\left(\frac{z+z^{-1}}{2}\right)}$  where C is positively oriented unit circle  $|z| = 1$   
 $\Rightarrow \int_0^{2\pi} \frac{d\theta}{a+b\cos\theta} = \frac{2}{i} \int_C \frac{dz}{bz^2+2az+b} = \frac{2}{i} \int_C F(z)dz$  with  $F(z) = \frac{1}{bz^2+2az+b}$
- To Calculate the poles of  $F(z)$   
 Firstly we will find the roots of  $bz^2 + 2az + b$  that will be as follows;  
 $\frac{-a \pm \sqrt{a^2-b^2}}{b}$  we may write these as  $\alpha = \frac{-a+\sqrt{a^2-b^2}}{b}$ ,  $\beta = \frac{-a-\sqrt{a^2-b^2}}{b}$   
 Since  $a > b > 0 \Rightarrow |\beta| > 1$ ,  $\alpha\beta = 1$  as  $|\alpha| < 1$   
 Here  $z = \alpha$  is the only simple pole which lie inside the C i.e.  $|z| = 1$   
 $\Rightarrow \text{Res}(F, \alpha) = \lim_{z \rightarrow \alpha} [(z-\alpha)F(z)] = \lim_{z \rightarrow \alpha} \left[ (z-\alpha) \frac{1}{bz^2+2az+b} \right]$   
 $\Rightarrow \text{Res}(F, \alpha) = \lim_{z \rightarrow \alpha} \left[ (z-\alpha) \frac{1}{b(z-\alpha)(z-\beta)} \right] = \lim_{z \rightarrow \alpha} \left[ \frac{1}{b(z-\beta)} \right] = \frac{1}{b(\alpha-\beta)}$   
 $\Rightarrow \text{Res}(F, \alpha) = \frac{1}{2b\frac{\sqrt{a^2-b^2}}{b}} = \frac{1}{2\sqrt{a^2-b^2}}$
- Using Cauchy Residue Formula make the form as follows;  
 $\Rightarrow \int_0^{2\pi} \frac{d\theta}{a+b\cos\theta} = \frac{2}{i} \int_C F(z)dz = \frac{2}{i} \times 2\pi i \times \text{Res}(F, \alpha) = \frac{2}{i} \times 2\pi i \times \frac{1}{2\sqrt{a^2-b^2}}$   
 $\Rightarrow \int_0^{2\pi} \frac{d\theta}{a+b\cos\theta} = \frac{2\pi}{\sqrt{a^2-b^2}}$

**Likewise:** we can Prove that  $\int_0^{2\pi} \frac{d\theta}{a+b\sin\theta} = \frac{2\pi}{\sqrt{a^2-b^2}}$  where  $a > b > 0$

**Example:** Prove that  $\int_0^{2\pi} \frac{d\theta}{(a+b\cos\theta)^2} = \frac{2\pi a}{(a^2-b^2)^{3/2}}$

**Solution:**

Since we know that  $\int_0^{2\pi} \frac{d\theta}{a+b\cos\theta} = \frac{2\pi}{\sqrt{a^2-b^2}}$

$\Rightarrow \int_0^{2\pi} -\frac{d\theta}{(a+b\cos\theta)^2} = -\frac{1}{2} \cdot \frac{2\pi a}{(a^2-b^2)^{3/2}} \cdot 2a$  taking derivative w.r.to 'a'

$\Rightarrow \int_0^{2\pi} \frac{d\theta}{(a+b\cos\theta)^2} = \frac{2\pi a}{(a^2-b^2)^{3/2}}$

**Example:** Prove that  $\int_0^\pi \frac{d\theta}{(a+\cos\theta)^2} = \frac{\pi a}{(a^2-1)^{3/2}} ; a > 1$

**Solution:** Since we know that  $\int_0^{2\pi} \frac{d\theta}{(a+b\cos\theta)^2} = \frac{2\pi a}{(a^2-b^2)^{3/2}}$

$$\Rightarrow \int_0^{2\pi} \frac{d\theta}{(a+b\cos\theta)^2} = 2 \int_0^\pi \frac{d\theta}{(a+b\cos\theta)^2} = \frac{2\pi a}{(a^2-b^2)^{3/2}}$$

$$\Rightarrow \int_0^\pi \frac{d\theta}{(a+b\cos\theta)^2} = \frac{\pi a}{(a^2-b^2)^{3/2}} \Rightarrow \int_0^\pi \frac{d\theta}{(a+\cos\theta)^2} = \frac{\pi a}{(a^2-1)^{3/2}} \quad \text{using } b = 1$$

**Example:** Prove that  $\int_0^{2\pi} \frac{d\theta}{5+3\cos\theta} = \frac{\pi}{2}$

**Solution:** Since we know that  $\int_0^{2\pi} \frac{d\theta}{a+b\cos\theta} = \frac{2\pi}{\sqrt{a^2-b^2}}$

$$\Rightarrow \int_0^{2\pi} \frac{d\theta}{5+3\cos\theta} = \frac{2\pi}{\sqrt{5^2-3^2}} = \frac{2\pi}{4} \Rightarrow \int_0^{2\pi} \frac{d\theta}{5+3\cos\theta} = \frac{\pi}{2} \quad \text{using } a = 5, b = 3$$

**Example:** Prove that  $\int_0^{2\pi} \frac{d\theta}{1+a\sin\theta} = \frac{2\pi}{\sqrt{1-a^2}}$  where  $-1 < a < 1$

**Solution:**

- Put  $z = e^{i\theta} ; 0 \leq \theta \leq 2\pi \Rightarrow \frac{dz}{d\theta} = ie^{i\theta} = iz \Rightarrow d\theta = \frac{dz}{iz}$

- $\sin\theta = \frac{z-z^{-1}}{2i}$

- Rewrite the integral in the form  $\int_0^{2\pi} \frac{d\theta}{1+a\sin\theta} = \int_C \frac{\frac{dz}{iz}}{1+a\left(\frac{z-z^{-1}}{2i}\right)}$  where C is

positively oriented unit circle  $|z| = 1$

$$\Rightarrow \int_0^{2\pi} \frac{d\theta}{1+a\sin\theta} = \frac{2}{a} \int_C \frac{dz}{z^2 + \left(\frac{2i}{a}\right)z - 1} = \frac{2}{a} \int_C F(z) dz \quad \text{with } F(z) = \frac{1}{z^2 + \left(\frac{2i}{a}\right)z - 1}$$

- To Calculate the poles of  $F(z)$

Firstly we will find the roots of  $z^2 + \left(\frac{2i}{a}\right)z - 1$  that will be as follows;

$$\left(\frac{-1 \pm \sqrt{1-a^2}}{a}\right) i \text{ we may write these as } \alpha = \left(\frac{-1 + \sqrt{1-a^2}}{a}\right) i, \beta = \left(\frac{-1 - \sqrt{1-a^2}}{a}\right) i$$

Since  $|\alpha| < 1$  as  $|\beta| > 1$

Here  $z = \alpha$  is the only simple pole which lie inside the C i.e.  $|z| = 1$

$$\Rightarrow \text{Res}(F, \alpha) = \lim_{z \rightarrow \alpha} [(z-\alpha)F(z)] = \lim_{z \rightarrow \alpha} \left[ (z-\alpha) \frac{1}{z^2 + \left(\frac{2i}{a}\right)z - 1} \right]$$

$$\Rightarrow \text{Res}(F, \alpha) = \lim_{z \rightarrow \alpha} \left[ (z-\alpha) \frac{1}{(z-\alpha)(z-\beta)} \right] = \lim_{z \rightarrow \alpha} \left[ \frac{1}{(z-\beta)} \right] = \frac{1}{(\alpha-\beta)}$$

$$\Rightarrow \text{Res}(F, \alpha) = \frac{1}{2i\sqrt{1-a^2}} = \frac{1}{2i\sqrt{1-a^2}}$$

- Using Cauchy Residue Formula make the form as follows;

$$\Rightarrow \int_0^{2\pi} \frac{d\theta}{a+b\cos\theta} = \frac{2}{a} \int_C F(z) dz = \frac{2}{a} \times 2\pi i \times \text{Res}(F, \alpha) = \frac{2}{a} \times 2\pi i \times \frac{1}{2i\sqrt{a^2-b^2}}$$

$$\Rightarrow \int_0^{2\pi} \frac{d\theta}{1+a\sin\theta} = \frac{2\pi}{\sqrt{1-a^2}}$$



**Exercise 51: (visit @ Youtube “learning with Usman Hamid”)**

1. Prove that  $\int_0^\pi \frac{\cos\theta}{1-2a\cos\theta+a^2} = \frac{a^2\pi}{1-a^2}$  where  $-1 < a < 1$  or  $|a| < 1$
2. Prove that  $\int_0^{2\pi} \frac{d\theta}{5+4\sin\theta} = \frac{2\pi}{3}$
3. Prove that  $\int_{-\pi}^\pi \frac{d\theta}{1+\sin^2\theta} = \sqrt{2}\pi$
4. Prove that  $\int_0^{2\pi} \frac{\cos^2 3\theta d\theta}{5-4\cos 2\theta} = \frac{3\pi}{8}$
5. Prove that  $\int_0^{2\pi} \frac{d\theta}{1+a\cos\theta} = \frac{2\pi}{\sqrt{1-a^2}}$  where  $-1 < a < 1$
6. Prove that  $\int_0^\pi \sin^{2n}\theta d\theta = \frac{(2n)!}{2^{2n}(n!)^2} \pi$  where  $n = 1, 2, 3, \dots$
7. Prove that  $\int_0^\pi \frac{1+2\cos\theta d\theta}{5+4\cos\theta} = 0$
8. Prove that  $\int_0^\pi \frac{a d\theta}{a^2+\sin^2\theta} = \frac{\pi}{\sqrt{1+a^2}}$  where  $a > 0$
9. Evaluate by means of contour integration  $\int_0^\pi \frac{\cos 2\theta d\theta}{1-2a\cos\theta+a^2}$  where  $a^2 > 0$
10. Prove that  $\int_0^{2\pi} \frac{\cos 2\theta d\theta}{5+4\cos\theta} = \frac{\pi}{6}$
11. Prove that  $\int_0^{2\pi} \frac{\cos^2 3\theta d\theta}{1-2p\cos 2\theta+p^2} = \frac{\pi(1-p+p^2)}{1-p}$  where  $0 < p < 1$
12. Evaluate the integral  $\int_0^{2\pi} \frac{(1+2\cos\theta)^n \cos n\theta}{3+2\cos\theta} d\theta$
13. Prove that  $\int_0^{2\pi} e^{\cos\theta} \cos(n\theta - \sin\theta) d\theta = \frac{2\pi}{n!}$
14. Prove that  $\int_0^{2\pi} e^{\cos\theta} \cos(\sin\theta) \cos\theta d\theta = \pi$
15. Prove that  $\int_0^{2\pi} \frac{d\theta}{(a+b\cos^2\theta)^2} = \frac{\pi(2a+b)}{a^{3/2}(a+b)^{3/2}}$
16. Prove that  $\int_0^{2\pi} \cos^{2n}\theta d\theta = \frac{1.3.5\dots(2n-1)}{2.4.6\dots 2n} 2\pi$  where  $n = 1, 2, 3, \dots$
17. Prove that  $\int_0^{2\pi} \frac{\cos 3\theta d\theta}{5-4\cos\theta} = \frac{\pi}{12}$
18. Prove that  $\int_0^{2\pi} \frac{d\theta}{2+\cos\theta} = \frac{2\pi}{\sqrt{3}}$
19. Prove that  $\int_0^{2\pi} \frac{d\theta}{1+a\cos\theta} = \frac{2\pi}{\sqrt{1-a^2}}$  where  $a > 0, a^2 < 1$
20. Prove that  $\int_0^{2\pi} \frac{\cos 3\theta d\theta}{10-8\cos\theta} = \frac{\pi}{24}$
21. Prove that  $\int_0^{2\pi} \frac{d\theta}{(2+\cos\theta)^2} = \frac{4\pi}{3\sqrt{3}}$

**TYPE – II:**

If we have an integral of the form  $\int_0^{\infty} f(x) dx$  or  $\int_{-\infty}^{\infty} f(x) dx$  then we can solve it using following procedure.

- Replace 'x' by 'z' in the integrand and test whether  $zf(z) \rightarrow 0$  as  $|z| \rightarrow \infty$
- Find the poles of  $f(z)$ , locate those poles which lie in the upper half plane. Find the residue at the located poles.
- Use formula  $\int_{-\infty}^{\infty} f(x) dx = 2\pi i \sum R^+$  or  $\int_0^{\infty} f(x) dx = \pi i \sum R^+$  where  $\sum R^+$  denotes sum of residues at poles lying in the upper half plane.

**Remark:**

- No poles lies on the real axis.
- Let  $f(z) = \frac{P(z)}{Q(z)}$  where  $P(z)$  and  $Q(z)$  are polynomials such that  $Q(z) = 0$  has no real roots. And the degree of  $P(z)$  is at least 2 less than that of  $Q(z)$  so that  $zf(z) \rightarrow 0$  as  $|z| \rightarrow \infty$

**Example:** Prove that  $\int_{-\infty}^{\infty} \frac{dx}{(x^2+1)^2} = \frac{3\pi}{8}$

**Solution:**

- Replace 'x' by 'z' in the integrand and test whether  $zf(z) \rightarrow 0$  as  $|z| \rightarrow \infty$

$$\text{Given } f(x) = \frac{1}{(x^2+1)^2} \Rightarrow f(z) = \frac{1}{(z^2+1)^2} \Rightarrow zf(z) = z \frac{1}{(z^2+1)^2}$$

Clearly  $zf(z) \rightarrow 0$  as  $|z| \rightarrow \infty$

- Find the poles of  $f(z)$ , locate those poles which lie in the upper half plane.

The poles of  $f(z)$  are at  $z = \pm i$  of order 3. The only pole which lies in the upper half plane is  $z = i$  of order 3.

- Find the residue at the located poles. i.e.  $z = i$  of order 3

$$\text{Res}(f, i) = \frac{1}{2!} \lim_{z \rightarrow i} \frac{d^2}{dz^2} \left[ (z-i)^3 \frac{1}{(z-i)^3(z+i)^3} \right]$$

$$\text{Res}(f, i) = \frac{1}{2} \lim_{z \rightarrow i} \frac{d^2}{dz^2} \left[ \frac{1}{(z+i)^3} \right] = \frac{6}{32i}$$

- Use formula  $\int_{-\infty}^{\infty} f(x) dx = 2\pi i \sum R^+$

$$\Rightarrow \int_{-\infty}^{\infty} \frac{dx}{(x^2+1)^2} = 2\pi i \times \frac{6}{32i} = \frac{3\pi}{8} \quad \text{as required.}$$

**Example:** Prove that  $\int_0^{\infty} \frac{dx}{x^4+a^4} = \frac{\pi}{2\sqrt{2}a^4}$  where  $a > 0$

**Solution:**

- Replace 'x' by 'z' in the integrand and test whether  $zf(z) \rightarrow 0$  as  $|z| \rightarrow \infty$

$$\text{Given } f(x) = \frac{dx}{x^4+a^4} \Rightarrow f(z) = \frac{1}{z^4+a^4} \Rightarrow zf(z) = z \left( \frac{1}{z^4+a^4} \right)$$

Clearly  $zf(z) \rightarrow 0$  as  $|z| \rightarrow \infty$

- Find the poles of  $f(z)$ , locate those poles which lie in the upper half plane.

The poles of  $f(z)$  are the roots of  $z^4 + a^4 = 0$

$$\Rightarrow z^4 = -a^4 \Rightarrow z^4 = a^4 e^{(2n+1)\pi i} \Rightarrow z = a e^{\frac{(2n+1)\pi i}{4}}; n = 0, 1, 2, 3$$

The poles are at  $a e^{\frac{\pi i}{4}}, a e^{\frac{3\pi i}{4}}, a e^{\frac{5\pi i}{4}}, a e^{\frac{7\pi i}{4}}$ . The only pole which lies in the upper half plane are  $a e^{\frac{\pi i}{4}}, a e^{\frac{3\pi i}{4}}$

- Find the residue at the located poles

Let  $z = \beta$  denote any one of these poles. Such that in  $z^4 + a^4 = 0$  we have  $\beta^4 = -a^4$

$$\text{Res}(f, \beta) = \lim_{z \rightarrow \beta} \left[ (z - \beta) \frac{1}{z^4 + a^4} \right]; \text{ } \frac{0}{0} \text{ form}$$

$$\text{Res}(f, \beta) = \lim_{z \rightarrow \beta} \left[ \frac{1}{4z^3} \right] = \frac{1}{4\beta^3} = \frac{\beta}{4\beta^4} = \frac{\beta}{-4a^4} \therefore \beta^4 = -a^4$$

$$\text{Sum of Residues} = \sum R^+ = -\frac{1}{4a^4} [\beta] = -\frac{1}{4a^4} \left[ e^{\frac{\pi i}{4}} + e^{\frac{3\pi i}{4}} \right]$$

$$\text{Sum of Residues} = \sum R^+ = -\frac{1}{4a^4} \left[ \frac{e^{\frac{\pi i}{4}} + e^{\frac{3\pi i}{4}}}{2i} \right] \times 2i$$

$$\text{Sum of Residues} = \sum R^+ = -\frac{2i}{4a^4} \text{Sin} \frac{\pi}{4} = -\frac{2i}{4a^4} \frac{1}{\sqrt{2}} = -\frac{i}{2\sqrt{2}a^4}$$

- Use formula  $\int_0^{\infty} f(x) dx = \pi i \sum R^+$

$$\Rightarrow \int_0^{\infty} \frac{dx}{x^4+a^4} = \pi i \times \frac{-i}{2\sqrt{2}a^4} = \frac{\pi}{2\sqrt{2}a^4} \quad \text{as required.}$$

**Exercise 52: (visit @ Youtube “learning with Usman Hamid”)**

1. Evaluate the following integrals.

i.  $\int_0^{\infty} \frac{dx}{x^6+1} = \frac{\pi}{3}$

ii.  $\int_0^{\infty} \frac{dx}{(x^2+1)^2} = \frac{\pi}{4}$

iii.  $\int_0^{\infty} \frac{dx}{x^4+1} = \frac{\pi\sqrt{2}}{4} = \frac{\pi}{2\sqrt{2}}$

iv.  $\int_0^{\infty} \frac{x^2 dx}{x^6+1} = \frac{\pi}{6}$

v.  $\int_0^{\infty} \frac{x^2 dx}{(x^2+1)(x^2+4)} = \frac{\pi}{6}$

vi.  $\int_0^{\infty} \frac{x^2 dx}{(x^2+9)(x^2+4)^2} = \frac{\pi}{200}$

vii.  $\int_{-\infty}^{\infty} \frac{dx}{x^2+2x+2} = -\frac{\pi}{5}$

viii.  $\int_{-\infty}^{\infty} \frac{dx}{(x^2+1)(x^2+2x+2)} = -\frac{\pi}{5}$

2. Prove that  $\int_{-\infty}^{\infty} \frac{x^2 dx}{(x^2+a^2)^3} = \frac{\pi}{8a^2}$ . Provided that  $R(a)$  is positive. What is the value of this integral if  $R(a)$  is negative?

3. Evaluate the following integrals.

i.  $\int_0^{\infty} \frac{x^2 dx}{x^4-6x^2+25} = \frac{\pi}{20}$

ii.  $\int_0^{\infty} \frac{x^6 dx}{(x^4+a^4)^2} = \frac{3\sqrt{2}\pi}{16a}$

iii.  $\int_0^{\infty} \frac{x dx}{(x^2+1)(x^2+2x+2)} = -\frac{\pi}{5}$

iv.  $\int_{-\infty}^{\infty} \frac{dx}{(a+bx^2)^4} = \frac{\pi}{16a^{3/2}b^{5/2}}$

v.  $\int_{-\infty}^{\infty} \frac{x^4 dx}{(x^2+a^2)(x^2+b^2)^2} = \frac{\pi(a+2b)}{2ab^3(a+b)^2}$

vi.  $\int_{-\infty}^{\infty} \frac{1}{(x^2+1)(x^2+9)} dx$

vii.  $\int_{-\infty}^{\infty} \frac{1}{x^4+1} dx$

**TYPE – III:**

If we have an integral of the form  $\int_{-\infty}^{\infty} \frac{P(x)}{Q(x)} \cos mx \, dx$  or  $\int_{-\infty}^{\infty} \frac{P(x)}{Q(x)} \sin mx \, dx$  or  $\int_0^{\infty} \frac{P(x)}{Q(x)} \cos mx \, dx$  or  $\int_0^{\infty} \frac{P(x)}{Q(x)} \sin mx \, dx$  where then we can solve it using following procedure.

- Replace 'x' by 'z' in the integrand  $f(x) = \frac{P(x)}{Q(x)}$  and  $\sin mx$  or  $\cos mx$  by  $e^{imz}$
- Find the poles of  $f(z)e^{imz}$ , locate those poles which lie in the upper half plane. Find the residue at the located poles.
- Then by Cauchy Residue theorem use the following formulae
 
$$\int_{-\infty}^{\infty} f(x) \sin mx \, dx = \text{Im}(2\pi i \sum R)$$

$$\int_{-\infty}^{\infty} f(x) \cos mx \, dx = \text{Re}(2\pi i \sum R)$$

$$\int_0^{\infty} f(x) \sin mx \, dx = \text{Im}(\pi i \sum R)$$

$$\int_0^{\infty} f(x) \cos mx \, dx = \text{Re}(\pi i \sum R)$$

**Remark:**

- $P(x)$  and  $Q(x)$  are polynomials such that  $Q(x) = 0$  has no real roots. And the degree of  $Q(x)$  exceeds the degree of  $P(x)$
- **Jordan's Inequality:**

$$\frac{2\theta}{\pi} \leq \sin \theta \leq \theta \quad \text{where } 0 \leq \theta \leq \frac{\pi}{2}$$

Or  $\int_0^{\pi} e^{-R \sin \theta} \, d\theta < \frac{\pi}{R} \quad ; R > 0$

Or  $\int_0^{\frac{\pi}{2}} e^{-R \sin \theta} \, d\theta \leq \frac{\pi}{2R} \quad ; R > 0$

- **Jordan's Lemma:**

if  $f(z)$  is complex valued function such that  $f(z) \rightarrow 0$  as  $z \rightarrow \infty$  and  $f(z)$  is meromorphic in the upper half plane then

$$\lim_{R \rightarrow \infty} \int_C f(z) e^{imz} \, dz = 0$$

where C denotes the semi-circle  $|z| = R; \text{Im}(z) > 0$

Or if a function  $f(z)$  is analytic at all points in the upper half plane that are exterior to the semi circle  $|z| = R_0$ . and if  $C_R$  denotes a semi circle  $z = R e^{i\theta}$  ( $0 \leq \theta \leq \pi$ ) where  $R > R_0$  then for all points z on  $C_R$  there will be a positive constant  $M_R$  such that

$$|f(z)| \leq M_R \quad \text{and} \quad \lim_{R \rightarrow \infty} M_R = 0$$

**Example:** Evaluate  $\int_0^{\infty} \frac{\cos mx dx}{a^2+x^2}$  and deduce the value of  $\int_0^{\infty} \frac{x \sin mx dx}{a^2+x^2}$  where 'a' and 'm' are constants.

**Solution:**

- The given integral  $\int_0^{\infty} \frac{\cos mx dx}{a^2+x^2}$  becomes  $\int_C \frac{e^{imz} dz}{z^2+a^2}$
- The poles of  $f(z)e^{imz} = \frac{e^{imz}}{z^2+a^2}$  are the zeros of  $z^2 + a^2 = 0$   
 $\Rightarrow z^2 = -a^2 \Rightarrow z = \pm ai$ . The only pole which lies in the upper half plane is  $z = ai$  of order 1.

$$Res(f, ai) = \lim_{z \rightarrow ai} \left[ (z - ai) \frac{e^{imz}}{z^2+a^2} \right] = \frac{e^{-ma}}{2ai}$$

- Then by Cauchy Residue theorem use the following formulae

$$\int_0^{\infty} f(x) \cos mx dx = Re(\pi i \sum R)$$

$$\int_0^{\infty} \frac{\cos mx dx}{a^2+x^2} = Re \left( \pi i \times \frac{e^{-ma}}{2ai} \right) = \frac{\pi}{2a} e^{-ma}$$

$$\text{Diff. w.r.to 'm' we get} \quad \int_0^{\infty} \frac{-\sin mx \cdot x dx}{a^2+x^2} = \frac{\pi}{2a} e^{-ma} (-a)$$

$$\int_0^{\infty} \frac{x \sin mx dx}{a^2+x^2} = \frac{\pi}{2} e^{-ma}$$

**Example:** Prove that  $\int_{-\infty}^{\infty} \frac{\cos x dx}{(x^2+a^2)(x^2+b^2)} = \frac{\pi}{a^2-b^2} \left( \frac{e^{-b}}{b} - \frac{e^{-a}}{a} \right)$  ;  $a > b > 0$

**Solution:**

- The given integral  $\int_{-\infty}^{\infty} \frac{\cos x dx}{(x^2+a^2)(x^2+b^2)}$  becomes  $\int_C \frac{e^{iz} dz}{(z^2+a^2)(z^2+b^2)}$
- The poles of  $f(z)e^{imz} = \frac{e^{iz} dz}{(z^2+a^2)(z^2+b^2)}$  are  $z = \pm ai$  ,  $z = \pm bi$

The only pole which lies in the upper half plane are  $z = ai, bi$  of order 1.

$$Res(f, ai) = \lim_{z \rightarrow ai} \left[ (z - ai) \frac{e^{iz} dz}{(z^2+a^2)(z^2+b^2)} \right]$$

$$Res(f, ai) = \lim_{z \rightarrow ai} \left[ (z - ai) \frac{e^{iz} dz}{(z-ai)(z+ai)(z^2+b^2)} \right]$$

$$Res(f, ai) = \lim_{z \rightarrow ai} \left[ \frac{e^{iz} dz}{(z+ai)(z^2+b^2)} \right] = \frac{e^{-a}}{2ai(b^2-a^2)}$$

$$Res(f, bi) = \lim_{z \rightarrow bi} \left[ (z - bi) \frac{e^{iz} dz}{(z^2+a^2)(z^2+b^2)} \right]$$

$$Res(f, bi) = \lim_{z \rightarrow bi} \left[ (z - bi) \frac{e^{iz} dz}{(z-bi)(z+bi)(z^2+a^2)} \right]$$

$$Res(f, bi) = \lim_{z \rightarrow bi} \left[ \frac{e^{iz} dz}{(z+bi)(z^2+a^2)} \right] = \frac{e^{-b}}{2bi(a^2-b^2)}$$

- Then by Cauchy Residue theorem use the following formulae

$$\int_{-\infty}^{\infty} f(x) \cos mx dx = Re(2\pi i \sum R)$$

$$\int_{-\infty}^{\infty} \frac{\cos x dx}{(x^2+a^2)(x^2+b^2)} = Re \left[ 2\pi i \times \left( \frac{e^{-a}}{2ai(b^2-a^2)} + \frac{e^{-b}}{2bi(a^2-b^2)} \right) \right] = \frac{\pi}{a^2-b^2} \left( \frac{e^{-b}}{b} - \frac{e^{-a}}{a} \right)$$

**Example:** Prove that  $\int_{-\infty}^{\infty} \frac{x \sin 2x dx}{x^2+3} = \pi e^{-2\sqrt{3}}$

**Solution:**

- The given integral  $\int_{-\infty}^{\infty} \frac{x \sin 2x dx}{x^2+3}$  becomes  $\int_C \frac{z e^{i2z} dz}{z^2+3}$
- The poles of  $f(z)e^{imz} = \frac{z e^{i2z}}{z^2+3}$  are  $z = \pm\sqrt{3}i$

The only pole which lies in the upper half plane is  $z = \sqrt{3}i$  of order 1.

$$\operatorname{Res}(f, \sqrt{3}i) = \lim_{z \rightarrow \sqrt{3}i} \left[ (z - \sqrt{3}i) \frac{z e^{i2z}}{z^2+3} \right]$$

$$\operatorname{Res}(f, \sqrt{3}i) = \lim_{z \rightarrow \sqrt{3}i} \left[ (z - \sqrt{3}i) \frac{z e^{i2z}}{(z - \sqrt{3}i)(z + \sqrt{3}i)} \right]$$

$$\operatorname{Res}(f, \sqrt{3}i) = \lim_{z \rightarrow \sqrt{3}i} \left[ \frac{z e^{i2z}}{(z + \sqrt{3}i)} \right] = \frac{\sqrt{3}i e^{i2\sqrt{3}i}}{(\sqrt{3}i + \sqrt{3}i)} = \frac{\sqrt{3}i e^{i2\sqrt{3}i}}{2\sqrt{3}i} = \frac{1}{2} e^{-2\sqrt{3}}$$

- Then by Cauchy Residue theorem use the following formulae

$$\int_{-\infty}^{\infty} f(x) \sin mx dx = \operatorname{Im}(2\pi i \sum R)$$

$$\int_{-\infty}^{\infty} \frac{x \sin 2x dx}{x^2+3} = \operatorname{Im} \left[ 2\pi i \times \frac{1}{2} e^{-2\sqrt{3}} \right]$$

$$\int_{-\infty}^{\infty} \frac{x \sin 2x dx}{x^2+3} = \operatorname{Im} [\pi i e^{-2\sqrt{3}}] = \pi e^{-2\sqrt{3}}$$

$$\text{Or} \quad \int_0^{\infty} \frac{x \sin 2x dx}{x^2+3} = \frac{\pi}{2} e^{-2\sqrt{3}}$$

**Exercise 53: (visit @ Youtube “learning with Usman Hamid”)**

1. Evaluate the following integrals.

- i.  $\int_0^{\infty} \frac{\text{Cos}ax}{x^2+1} dx = \frac{\pi}{2} e^{-a} ; a > 0$
- ii.  $\int_0^{\infty} \frac{\text{Cos}ax dx}{(x^2+b^2)^2} dx = \frac{\pi}{4b^3} (1+ab)e^{-ab} ; a > 0, b > 0$
- iii.  $\int_{-\infty}^{\infty} \frac{x \text{Sin}ax dx}{x^4+4} = \frac{\pi}{2} e^{-a} \text{Sin}a ; a > 0$
- iv.  $\int_{-\infty}^{\infty} \frac{x^3 \text{Sin}ax dx}{x^4+4} = \pi e^{-a} \text{Cos}a ; a > 0$
- v.  $\int_{-\infty}^{\infty} \frac{\text{Sin}x dx}{x^2+4x+5} = -\frac{\pi}{e} \text{Sin}2$
- vi.  $\int_{-\infty}^{\infty} \frac{x \text{Sin}x dx}{x^2+2x+2} = \frac{\pi}{e} (\text{Sin}1 + \text{Cos}1)$
- vii.  $\int_{-\infty}^{\infty} \frac{x \text{Sin}ax dx}{(x^2+1)(x^2+4)} = ???$
- viii.  $\int_0^{\infty} \frac{x^3 \text{Sin}ax dx}{(x^2+1)(x^2+9)} = ???$
- ix.  $\int_{-\infty}^{\infty} \frac{(x+1) \text{Cos}x dx}{x^2+4x+5} = \frac{\pi}{e} (\text{Sin}2 - \text{Cos}2)$
- x.  $\int_{-\infty}^{\infty} \frac{\text{Cos}x dx}{(x+a)^2+b^2} = ??? ; b > 0$

2. Evaluate the following integrals.

- i.  $\int_{-\infty}^{\infty} \frac{a \text{Cos}x + x \text{Sin}x}{x^2+a^2} dx$
- ii.  $\int_0^{\infty} \frac{\text{Cos}mx}{x^4+x^2+1} dx ; m > 0$
- iii.  $\int_0^{\infty} \frac{x \text{Sin}ax}{x^4+x^2+1} dx ; a \geq 4$
- iv.  $\int_0^{\infty} \frac{\text{Cos}mx}{x^4+a^4} dx$
- v.  $\int_0^{\infty} \frac{\text{Cos}ax}{x^4+4} dx$
- vi.  $\int_0^{\infty} \frac{x \text{Sin}x dx}{(x^2+1)(x^2+4)} = ???$
- vii.  $\int_0^{\infty} \frac{\text{Cos}^2 x dx}{(x^2+1)^2} dx$
- viii.  $\int_0^{\infty} \frac{x \text{Sin}x dx}{(x^2+a^2)^2} dx ; a > 0$
- ix.  $\int_{-\infty}^{\infty} \frac{\text{Sin}x dx}{x^2-2x+5} dx ; a > 0$
- x.  $\int_0^{\infty} \frac{x^3 \text{Sin}x dx}{(x^2+a^2)(x^2+b^2)} = ???$
- xi. Prove by contour integration  $\int_0^{\infty} \frac{\log(1+x^2)}{(1+z^2)} = \pi \log 2$
- xii.  $\int_0^{\infty} \frac{x \text{Sin}x}{x^2+9} dx = ???$



**JORDAN'S INEQUALITY: (1<sup>st</sup> method)**

According to this inequality  $\frac{2\theta}{\pi} \leq \sin\theta \leq \theta$  where  $0 \leq \theta \leq \frac{\pi}{2}$

**Proof:**

We know that  $0 \leq \theta \leq \frac{\pi}{2}$  then  $\cos\theta$  decreases steadily and consequently the mean ordinate of the graph of  $y = \cos x$  over the range  $0 \leq x \leq \theta$  also decreases steadily. But this mean ordinate is

$$\frac{1}{\theta} \int_0^{\theta} \cos x \, dx = \frac{\sin\theta}{\theta}$$

From above when  $0 \leq \theta \leq \frac{\pi}{2}$  implies  $\frac{2}{\pi} \leq \frac{\sin\theta}{\theta} \leq 1$

$\Rightarrow \frac{2\theta}{\pi} \leq \sin\theta \leq \theta$  as required.

**JORDAN'S INEQUALITY: (2<sup>nd</sup> method)**

According to this inequality

$$\int_0^{\pi} e^{-R\sin\theta} \, d\theta < \frac{\pi}{R} \quad ; R > 0 \quad \text{Or} \quad \int_0^{\frac{\pi}{2}} e^{-R\sin\theta} \, d\theta \leq \frac{\pi}{2R} \quad ; R > 0$$

**Proof:** Consider the following figure;

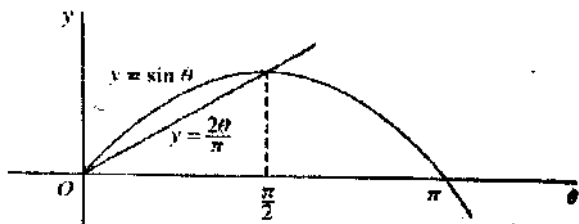

We first note from the graph of the functions  $y = \sin\theta$  and  $y = \frac{2\theta}{\pi}$

that  $\frac{2\theta}{\pi} \leq \sin\theta$  when  $0 \leq \theta \leq \frac{\pi}{2}$

Consequently  $e^{-R\sin\theta} \leq e^{-\frac{2R\theta}{\pi}}$  when  $0 \leq \theta \leq \frac{\pi}{2}$  where  $R > 0$

$$\Rightarrow \int_0^{\frac{\pi}{2}} e^{-R\sin\theta} \, d\theta \leq \int_0^{\frac{\pi}{2}} e^{-\frac{2R\theta}{\pi}} \, d\theta = \frac{\pi}{2R} (1 - e^{-R}) \quad ; R > 0$$

$$\Rightarrow \int_0^{\frac{\pi}{2}} e^{-R\sin\theta} \, d\theta \leq \frac{\pi}{2R} \quad ; R > 0$$

This is another form of inequality  $\int_0^{\pi} e^{-R\sin\theta} \, d\theta < \frac{\pi}{R} \quad ; R > 0$ , since the graph of  $y = \sin\theta$  is symmetric with respect to the vertical line  $\theta = \frac{\pi}{2}$  on the interval  $0 \leq \theta \leq \pi$

**JORDAN'S LEMMA:(1<sup>st</sup> method)**

If  $f(z)$  is complex valued function such that  $f(z) \rightarrow 0$  as  $z \rightarrow \infty$  and  $f(z)$  is meromorphic in the upper half plane then

$$\lim_{R \rightarrow \infty} \int_C f(z) e^{imz} dz = 0$$

where  $C$  denotes the semi-circle  $|z| = R; \text{Im}(z) > 0$

**Proof:** Consider  $f(z)$  has no singularities on  $C$  for sufficiently large values of  $R$ . Since  $\lim_{R \rightarrow \infty} f(z) = 0$  we have for a given  $\epsilon$

Therefore  $|f(z)| < \epsilon$  when  $|z| = R \leq R_0$  ;  $R_0 > 0$

Now let  $C$  denote any semi-circle with radius  $R$ . let  $z = R e^{i\theta}$  then we get

$$\int_C f(z) e^{imz} dz = \int_0^\pi f(R e^{i\theta}) e^{imR e^{i\theta}} R i e^{i\theta} d\theta$$

$$\int_C f(z) e^{imz} dz = \int_0^\pi e^{-mR \sin\theta} e^{imR \cos\theta} f(R e^{i\theta}) R i e^{i\theta} d\theta$$

$$\left| \int_C f(z) e^{imz} dz \right| = \left| \int_0^\pi e^{-mR \sin\theta} e^{imR \cos\theta} f(R e^{i\theta}) R i e^{i\theta} d\theta \right|$$

$$\left| \int_C f(z) e^{imz} dz \right| \leq \int_0^\pi |e^{-mR \sin\theta}| |e^{imR \cos\theta}| |f(R e^{i\theta})| |R| |i| |e^{i\theta}| d\theta$$

$$\left| \int_C f(z) e^{imz} dz \right| \leq \int_0^\pi e^{-mR \sin\theta} \epsilon R d\theta = 2 \epsilon R \int_0^{\frac{\pi}{2}} e^{-mR \sin\theta} d\theta$$

$$\left| \int_C f(z) e^{imz} dz \right| \leq 2 \epsilon R \int_0^{\frac{\pi}{2}} e^{-mR \sin\theta} d\theta$$

Using Jordan inequality  $\frac{2\theta}{\pi} \leq \sin\theta \leq \theta$  where  $0 \leq \theta \leq \frac{\pi}{2}$

$$\Rightarrow \left| \int_C f(z) e^{imz} dz \right| \leq 2 \epsilon R \int_0^{\frac{\pi}{2}} e^{-mR \frac{2\theta}{\pi}} d\theta = 2 \epsilon R \left[ \frac{e^{-mR \frac{2\theta}{\pi}}}{-mR \frac{2}{\pi}} \right]_0^{\frac{\pi}{2}} = -\frac{\pi \epsilon}{m} (e^{-mR} - 1)$$

$$\Rightarrow \left| \int_C f(z) e^{imz} dz \right| \leq \frac{\pi \epsilon}{m} (1 - e^{-mR}) < \frac{\pi \epsilon}{m} \text{ as } R \rightarrow \infty$$

$$\Rightarrow \int_C e^{imz} f(z) dz \rightarrow 0 \text{ as } \epsilon \rightarrow 0 \text{ as required.}$$

**JORDAN'S LEMMA: (2<sup>nd</sup> method)**

If a function  $f(z)$  is analytic at all points in the upper half plane that are exterior to the semi circle  $|z| = R_0$  . and if  $C_R$  denotes a semi circle  $z = Re^{i\theta}$  ( $0 \leq \theta \leq \pi$ ) where  $R > R_0$  then for all points  $z$  on  $C_R$  there will be a positive constant  $M_R$  such that

$$|f(z)| \leq M_R \quad \text{and} \quad \lim_{R \rightarrow \infty} M_R = 0$$

**Proof:** Consider the following figure;

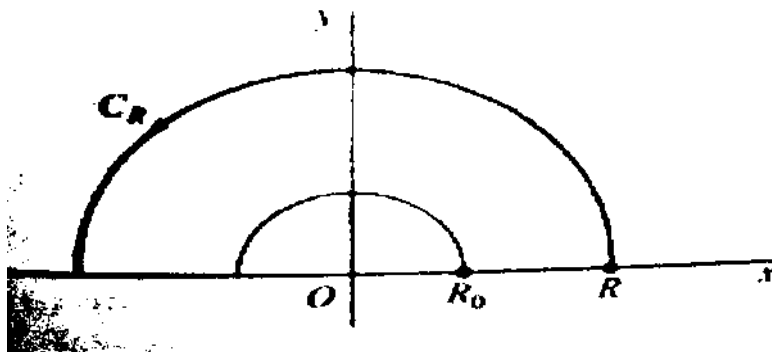

if  $f(z)$  is analytic at all points in the upper half plane that are exterior to the semi circle  $|z| = R_0$  . and if  $C_R$  denotes a semi circle  $z = Re^{i\theta}$  ( $0 \leq \theta \leq \pi$ ) where  $R > R_0$  then we write

$$\int_{C_R} f(z) e^{imz} dz = \int_0^\pi f(Re^{i\theta}) e^{imRe^{i\theta}} Rie^{i\theta} d\theta$$

$$\text{Since } |f(Re^{i\theta})| \leq M_R \text{ and } |e^{imRe^{i\theta}}| \leq e^{-mR\sin\theta}$$

Also using Jordan inequality  $\frac{2\theta}{\pi} \leq \sin\theta \leq \theta$  where  $0 \leq \theta \leq \frac{\pi}{2}$

$$\Rightarrow \left| \int_{C_R} f(z) e^{imz} dz \right| \leq M_R R \int_0^\pi e^{-mR\sin\theta} d\theta < \frac{\pi M_R}{m}$$

$$\Rightarrow \int_C e^{imz} f(z) dz \rightarrow 0 \text{ as } M_R \rightarrow 0 \text{ as required.}$$

---

**MISCELLANEOUS PROBLEMS**

---

**EXAMPLE:** Under the transformation  $(w + 1)^2 z = 4$ . Prove that if 'w' describes a unit circle then 'z' describes a parabola.

**Solution:** Consider  $(w + 1)^2 z = 4 \Rightarrow z = \frac{4}{(w+1)^2}$  .....(i)

$$(i) \Rightarrow r e^{i\theta} = \frac{4}{(e^{i\varphi} + 1)^2} \quad \because z = r e^{i\theta}, w = e^{i\varphi}$$

$$\Rightarrow \frac{(e^{i\varphi} + 1)^2}{4} = \frac{1}{r} e^{-i\theta} \Rightarrow \frac{(1 + \cos\varphi + i\sin\varphi)^2}{4} = \frac{1}{r} (\cos\theta - i\sin\theta)$$

$$\Rightarrow \frac{1 + \cos^2\varphi - \sin^2\varphi + 2\cos\varphi + 2i\sin\varphi + 2i\sin\varphi\cos\varphi}{4} = \frac{1}{r} (\cos\theta - i\sin\theta)$$

Comparing real and imaginary parts

$$\Rightarrow \frac{1}{r} \cos\theta = \frac{1 + \cos^2\varphi - \sin^2\varphi + 2\cos\varphi}{4} = 2\cos\varphi \frac{1 + \cos\varphi}{4} \quad \dots\dots\dots(ii)$$

$$\Rightarrow -\frac{1}{r} \sin\theta = \frac{2\sin\varphi + 2\sin\varphi\cos\varphi}{4} = 2\sin\varphi \frac{1 + \cos\varphi}{4} \quad \dots\dots\dots(iii)$$

Squaring and adding (ii) and (iii)

$$\Rightarrow \frac{1}{r^2} (\cos^2\theta + \sin^2\theta) = \frac{1}{4} (1 + \cos\varphi)^2 (\cos^2\varphi + \sin^2\varphi)$$

$$\Rightarrow \frac{1}{r^2} = \frac{1}{4} (1 + \cos\varphi)^2 \Rightarrow r^2 = \frac{4}{(1 + \cos\varphi)^2}$$

$$\Rightarrow r = \frac{2}{1 + \cos\varphi} \quad \text{This is the equation of parabola in } z - \text{ plane.}$$

**EXAMPLE:** Prove that  $\text{Cot}z = \frac{1}{z} + 2z \sum_{n=1}^{\infty} \frac{1}{z^2 - n^2\pi^2}$

**Solution:** Consider  $f(z) = \text{Cot}z - \frac{1}{z} = \frac{z\text{Cot}z - \text{Sin}z}{z\text{Sin}z}$

$$\lim_{z \rightarrow 0} f(z) = \lim_{z \rightarrow 0} \frac{z\text{Cot}z - \text{Sin}z}{z\text{Sin}z} \left( \frac{0}{0} \right) = \lim_{z \rightarrow 0} \frac{-z\text{Sin}z + \text{Cos}z - \text{Cos}z}{z\text{Cos}z + \text{Sin}z} \left( \frac{0}{0} \right)$$

$$\lim_{z \rightarrow 0} f(z) = \lim_{z \rightarrow 0} \frac{-z\text{Cos}z - \text{Sin}z}{\text{Cos}z - z\text{Sin}z + \text{Cos}z} = \frac{0}{2} = 0$$

Since  $f(0) = 0$ , therefore there is no singularity at  $z = 0$ , and the poles of  $f(z)$  are at  $z = n\pi$ ;  $n = \pm 1, \pm 2, \dots$

$$\text{Res}(f, n\pi) = \lim_{z \rightarrow n\pi} \left[ (z - n\pi) \frac{z\text{Cot}z - \text{Sin}z}{z\text{Sin}z} \right] \left( \frac{0}{0} \right)$$

$$\text{Res}(f, n\pi) = \lim_{z \rightarrow n\pi} \left[ (z - n\pi) \cdot \frac{-z\text{Sin}z + \text{Cos}z - \text{Cos}z}{z\text{Cos}z + \text{Sin}z} + 1 \cdot \frac{z\text{Cot}z - \text{Sin}z}{z\text{Sin}z} \right]$$

$$\text{Res}(f, n\pi) = \lim_{z \rightarrow n\pi} \left[ \frac{z\text{Cot}z - \text{Sin}z}{z\text{Cos}z - \text{Sin}z} \right] = \frac{n\pi(-1)^n}{n\pi(-1)^n} = 1$$

Now using formula  $f(z) = f(0) + \sum_{n=-\infty}^{\infty} b_n \left[ \frac{1}{z - a_n} + \frac{1}{a_n} \right]$

$$f(z) = 0 + \sum_{n=-\infty}^{\infty} 1 \cdot \left[ \frac{1}{z - n\pi} + \frac{1}{n\pi} \right] = \sum_{n=1}^{\infty} \left[ \frac{1}{z - n\pi} + \frac{1}{n\pi} + \frac{1}{z + n\pi} - \frac{1}{n\pi} \right]$$

$$f(z) = 2z \sum_{n=1}^{\infty} \frac{1}{z^2 - n^2\pi^2} \Rightarrow \text{Cot}z - \frac{1}{z} = 2z \sum_{n=1}^{\infty} \frac{1}{z^2 - n^2\pi^2}$$

$$\Rightarrow \text{Cot}z = \frac{1}{z} + 2z \sum_{n=1}^{\infty} \frac{1}{z^2 - n^2\pi^2}$$

# حرفِ آخر (10-10-2020)

خوش رہیں خوشیاں بانٹیں اور جہاں تک ہو سکے دوسروں کے لیے  
آسانیاں پیدا کریں۔

اللہ تعالیٰ آپ کو زندگی کے ہر موڑ پر کامیابیوں اور خوشیوں سے  
نوازے۔ (امین)

محمد عثمان حامد

چک نمبر 105 شمالی (گودھے والا) سرگودھا

UNIVERSITY OF SARGODHA

PUNJAB, PAKISTAN

0323 – 6032785

*For video lectures*

*@ You tube visit*

# ***Learning with Usman Hamid***

*visit facebook page “mathwath”*

*or contact: 0323 – 6032785*

**Availabel on MathCity.org**